

Microwave cable assemblies

Edition 2026

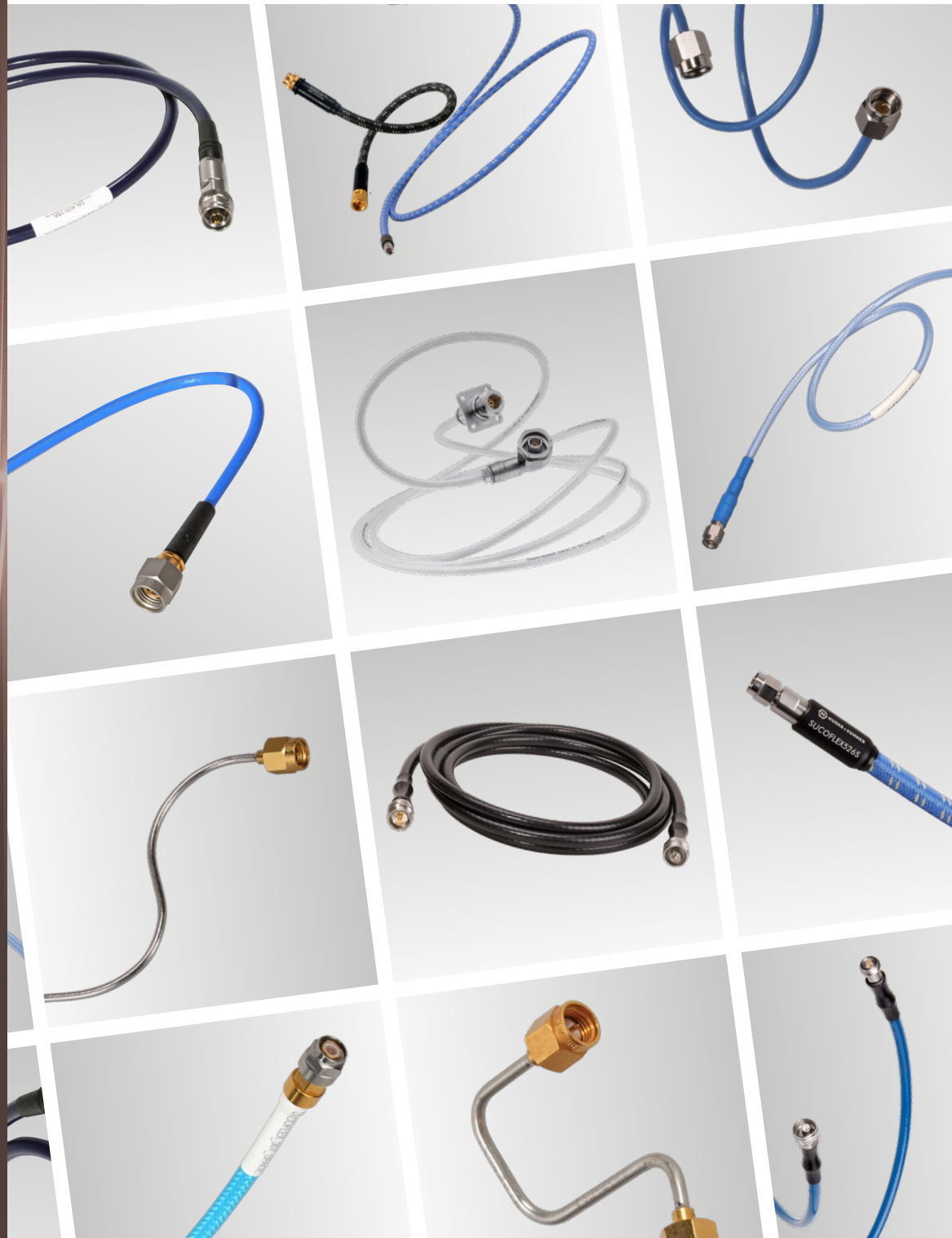

Advanced microwave cable assemblies for high-performance systems

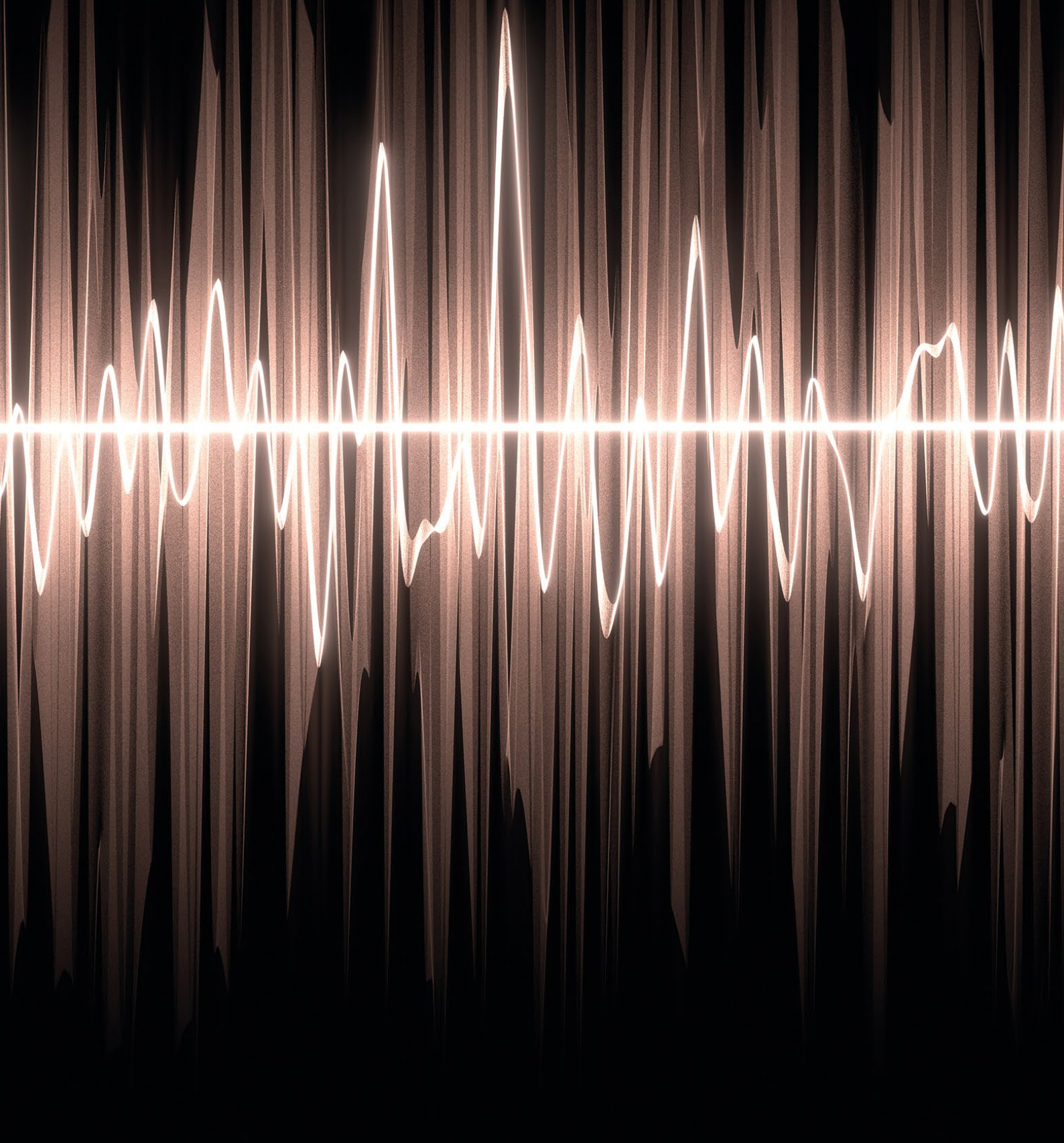

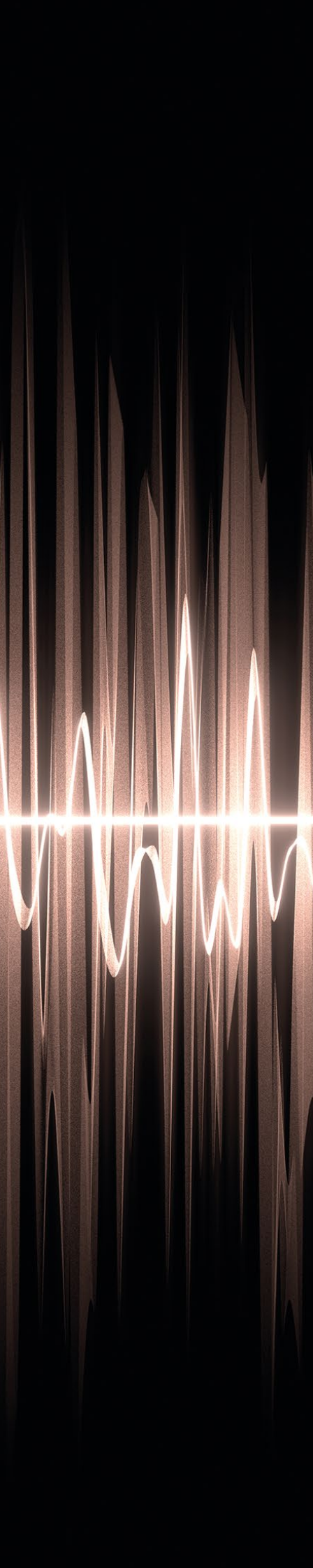

HUBER+SUHNER microwave cable and cable assemblies support both current and next-generation system architectures, enabling highest-frequency signal transmission while also supporting high-speed data transfer.

Our comprehensive microwave assembly portfolio, including all the available options such as protective jackets and precision connectors, are optimised for critical environments where reliability and electrical performance are essential. These assemblies are designed to maintain consistent electrical characteristics across a broad frequency spectrum, ensuring minimal insertion and return loss as well as excellent phase stability throughout their lifecycle.

Designed and built to withstand extreme operating conditions, our products deliver long-term durability and reliable performance in demanding environments. Leveraging deep expertise in advanced materials science and precision manufacturing, we develop application-specific interconnect solutions that meet industry standards and regulations, while also addressing the evolving requirements of emerging applications.

Our portfolio includes microwave cable assemblies with durable, form-stable, flexible, bend-to-the-end, lead-free, and lightweight designs, ensuring consistent performance across a wide range of applications. Supporting various interfaces, cable lengths, and diameters, they operate reliably from DC up to 100 GHz and beyond, with versatility that meets diverse customer specifications.

To empower our customers and accelerate design cycles, we offer a suite of online tools:

- **RF Assembly configurators** – Quickly customize cable assemblies to your exact requirements
- **Performance calculator** – Precisely estimate system performance
- **Application Engineering support** – Expert guidance from concept to deployment

Trusted by leading organisations across industries such as Test and Measurement, Aerospace and Defense, HUBER+SUHNER delivers quality products you can depend on – every single time.

Our long-standing customer relationships are founded on performance, continuous innovation, and close technical collaboration.

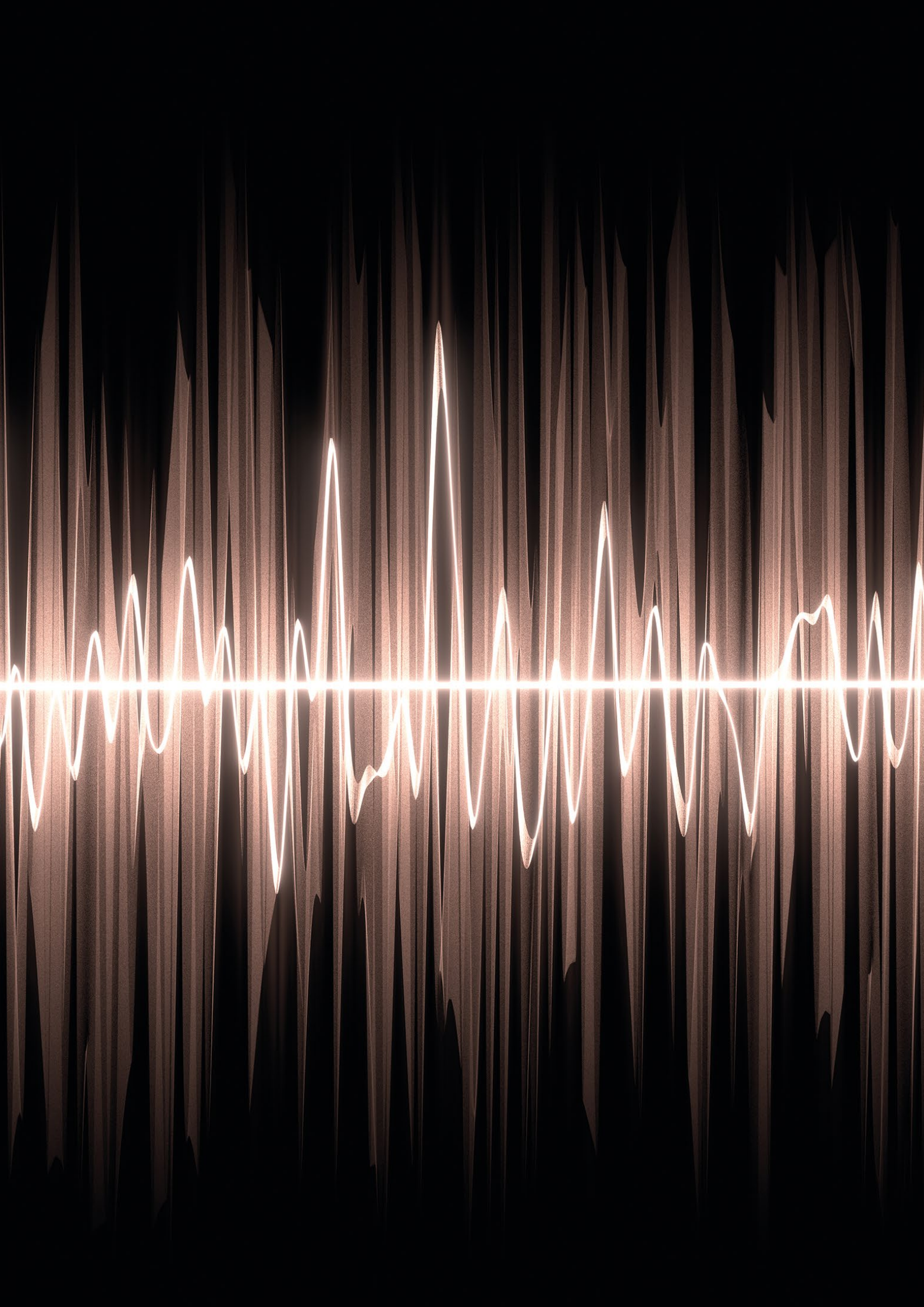

Content

General assembly information	6
Qualified, high performance microwave cable assemblies SUCOFLEX 100/300/500	10
SUCOFLIGHT	66
Qualified, low profile, high performance microwave cable assemblies MINIBEND family	70
Microwave test cable assemblies Sucotest/TL-8A/TL-P	94
Flexible microwave cable assemblies Multiflex/S-Series/Boa-flex/Eacon	108
Formstable and handformable microwave cables assemblies Sucoform/Semi-rigid/ SPJ/SM	128
Constant over Temperature (CT line) - Dielectric core technology for best phase stability vs. temperature	142
TVAC cable assemblies – thermal vacuum chamber test assemblies	150
Engineering information	160
Selection guide	170

General assembly information

Cables and connectors from the same manufacturer

HUBER+SUHNER develops and manufactures coaxial cables and connectors for most applications and in a multitude of versions. The connector series comprise over 1700 different types which prove their qualities daily worldwide. Demanding customers trust the reliability and quality of HUBER+SUHNER products. These products have been tested to IEC, MIL, CECC and other standards. Our extensive know-how in RF technology enables reliable and competent technical consulting and support. You stand to benefit from a well matched cable and connector range as well as many years vast experience of our engineers.

Microwave cable assemblies to your specifications

Make use of the HUBER+SUHNER custom design service. Increase efficiency and productivity in your company by ordering ready-to-use microwave cable assemblies from the specialists. Expert assembly by soldering, clamp or crimp technique and inspection records according to your specifications enable you to order with confidence.

Advantages of microwave cable assemblies

Purchasing of ready-made microwave cable assembly lines provides important benefits:

- Perfect assembly, no rejects
- No need for training assembly personnel
- No capital investment for assembly provisions
- Precisely matched cables and connectors from the same manufacturer
- HUBER+SUHNER guaranties quality



General assembly information

Assembly shop capability

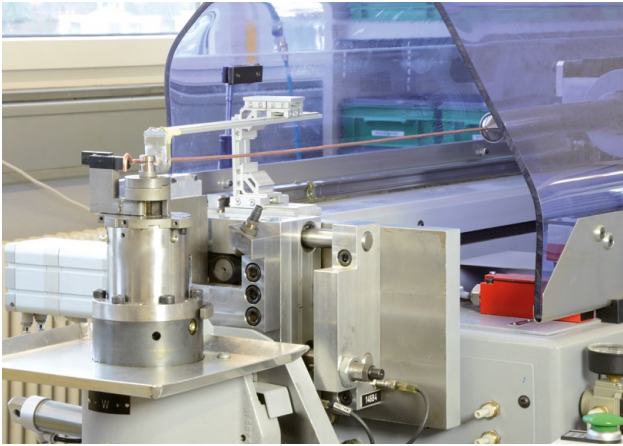

Automatic bending

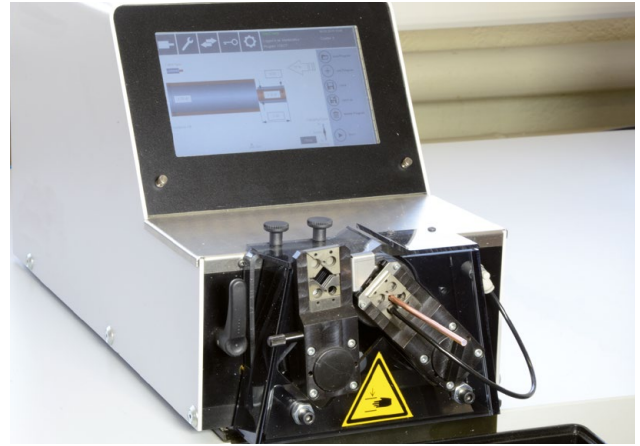

Automatic stripping

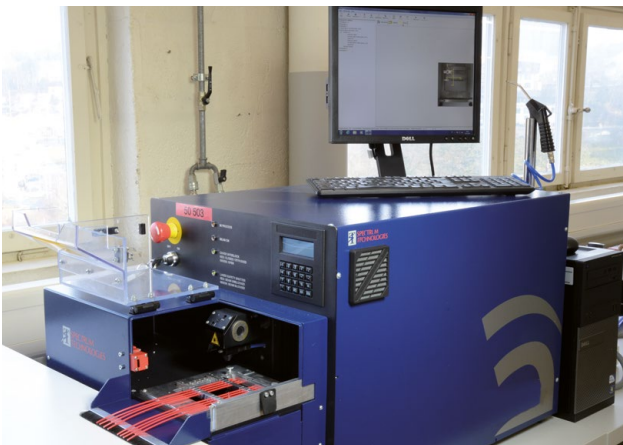

Automatic laser stripping



Temperature controlled soldering



Clean room

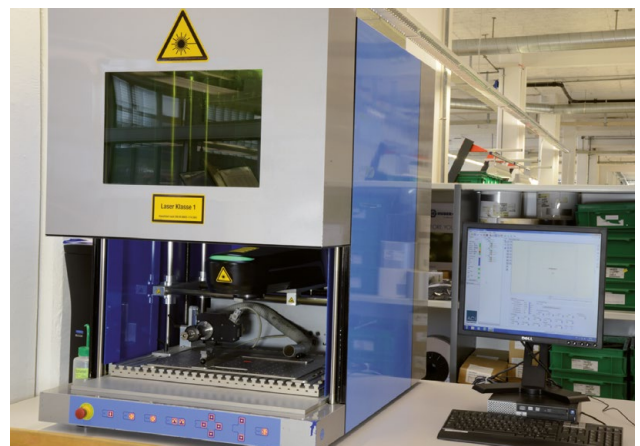

Laser marking

General assembly information

Length definition and assembly design

The assembly lengths are measured using the connector reference plane of straight plug and jack connectors and the pin centerline of right angle connectors.

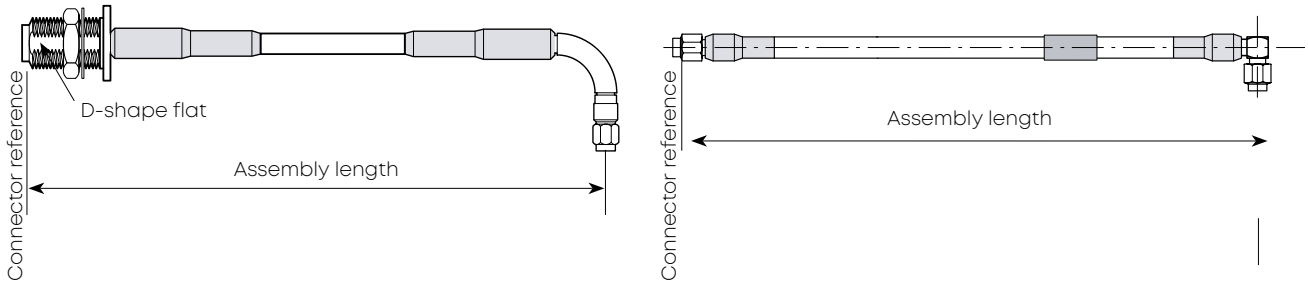

Standard assembly length tolerances

SUCOFLEX®, Sucotest

≤ 400 mm ± 2.0 mm
 > 400 mm ± 0.5 %

Minibend

± 7.1 mm

Multiflex and S-series

≤ 500 mm ± 5.0 mm
 ≤ 1000 mm ± 7.0 mm
 ≤ 2000 mm ± 12.0 mm
 > 2000 mm ± 0.6 %

Sucoform

≤ 500 mm ± 3.0 mm
 ≤ 1000 mm ± 5.0 mm
 ≤ 2000 mm ± 8.0 mm
 > 2000 mm ± 0.4 %

Semi-rigid, Boa-flex, Ever-flex, Steel-flex, Cobra-flex

≤ 500 mm ± 2.0 mm
 ≤ 1000 mm ± 3.0 mm
 ≤ 2000 mm ± 5.0 mm
 > 2000 mm ± 0.3 %

Tighter assembly tolerances are available on special request. Please ask your local HUBER+SUHNER partner.

Angular displacement and D-shape flat of connectors

With HUBER+SUHNER microwave cable assemblies that have right angle or right angle and bulkhead connectors the relative angular displacement must be specified as shown in the following sketches.

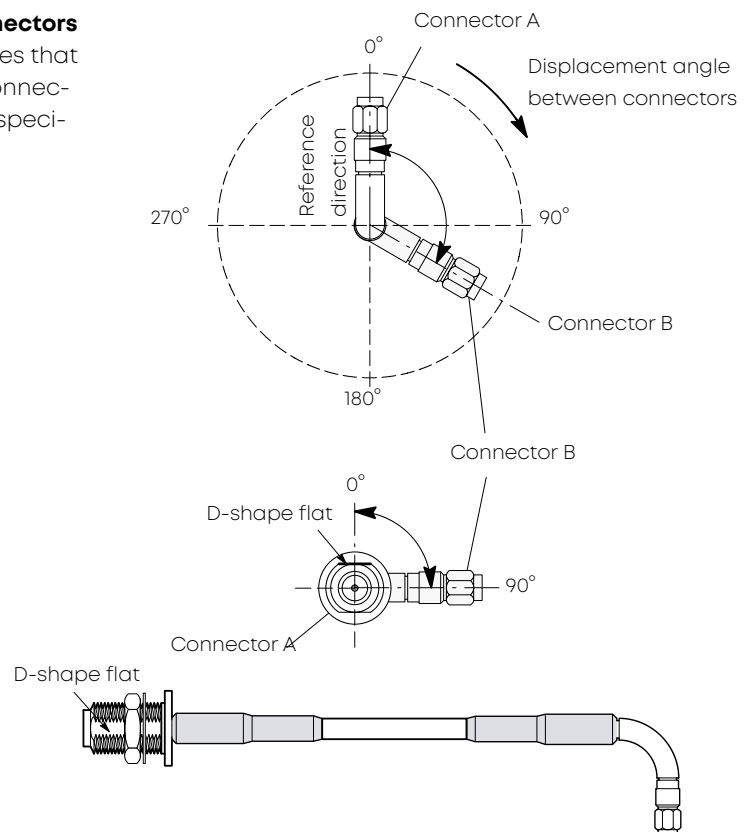

General assembly information

Care and handling instructions

HUBER+SUHNER microwave cable assemblies of all types offer a long service life providing they are treated with the appropriate care and attention. Microwave cable assemblies are high precision system components and require proper handling in order to ensure that measured performance values are maintained.

To achieve the maximum installed performance the following guidelines should be followed:

1. Assemblies should remain in their original packaging for delivery and storage. Storage temperature should be between -50 and $+80$ °C and the relative humidity should not exceed 85%.
2. Carefully unpack assemblies before installation. Avoid kinking cables when straightening from a coil or reel.
3. Ensure that the surroundings are clean and free of dust, dirt and any other particles that could enter unsealed connector interfaces.
4. Use protective caps to prevent contamination whenever connectors are unmated.
5. Where interfaces are contaminated, particles can be removed with dry, oil-free compressed air. Please use eye-protection. Interfaces can be cleaned with dry cotton swabs. Do not use hard handtools or solvents. Do not blow into interfaces or use normal compressed-air.
6. Choose the installation routing using the largest bend radii possible. Small bend radii may affect electrical performance. Exceeding the specified limits during the installation process could cause a permanent degradation.
7. Avoid twisting microwave cable assemblies. Torsion of this type of assembly can alter the relative diameters of cable layers and affects the electrical characteristics. Exceeding the limit of 10° per metre during installation process could cause a permanent degradation.
8. Assemblies should be fixed in place without excess pressure. The use of cable ties should be avoided where possible, as they can easily exert more force than this. If cable ties must be used then they should be as wide as possible and still allow movement of the cable. Avoid placing fixings at regular intervals.
9. Examine interfaces for damage and/or contamination before mating.
10. Discharge connectors before mating or ensure that they are connected to a suitable ground.
11. When mating connectors with a screwed interface always hold the connector bodies and turn only the coupling nut. This avoids twisting the cable and ensures minimum wear on the connector pins.
12. Do not exceed the specified torque.

Qualified, high performance microwave cable assemblies



The flexible SUCOFLEX® series microwave cable assemblies offer superior electrical and mechanical performance for static and dynamic applications. This series is a high-end product designed to provide optimal performance up to 70 GHz, where stringent electrical requirements, in particular electrical stability and low loss, are important. Ideally suited for test and measurement applications and defense systems. Additional lightweight high end versions are designed to meet the stringent needs of space flights systems (i. e. satellites) and aerospace systems (aircrafts, helicopters, missiles), which are subject to extremely severe operating conditions. SUCOFLEX is only available as assembly.

SUCOFLEX®

- Introduction
- Advantages
- Overview
- Qualifications



SUCOFLEX 100

The low loss, high performance microwave cable assembly

- For static and dynamic applications up to 40 GHz
- Excellent return- and insertion loss
- Ideal for aerospace, defense, and medical applications, these high-end cables provide reliability where precision matters most
- Featuring a rotary-swaged low-loss inner conductor and rugged construction, SUCOFLEX 118/126 assemblies withstand over 100,000 flex cycles without performance degradation, ensuring exceptional longevity.



SUCOFLEX 300

The light weight, low loss microwave cable assemblies

- SUCOFLEX 300 series offers a consistently outstanding mechanical and electrical performance, stability and reliability up to 18 GHz
- Weight reduction of up to 40 % compared to our conventional products
- Assemblies produced in a clean environment room



SUCOFLEX 500

When it comes to test and measurement, SUCOFLEX 500 assemblies guarantee the highest level of satisfaction

- Applicable up to 70 GHz
- Torque, crush and kink resistant
- Precise and repeatable measurements
- Long service life
- Reduce total cost of test with durable, reliable performance
- Increased test and measurement efficiency saving costs due to reduced calibration intervals

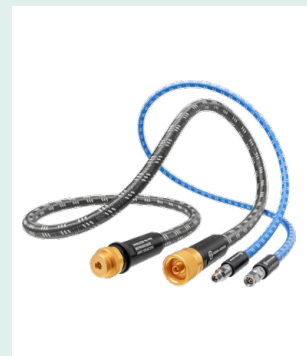

Introduction SUCOFLEX®

What are SUCOFLEX assemblies?

The assembly lengths are measured using the connector reference plane of straight plug and jack connectors and the pin centerline of right angle connectors.

SUCOFLEX

are flexible microwave cable assemblies offering better transmission characteristics than semi-rigid cables.

SUCOFLEX

comprises an entire system of optimally matched components such as:

- Microwave cables
- Connectors
- Ruggedisations
- Marking sleeves
- ...



SUCOFLEX

is manufactured by highly qualified HUBER+SUHNER employees and tested against strict quality standards under controlled conditions. This results in microwave cable assemblies meeting all of your needs for top quality and high precision reproducibility.

SUCOFLEX

is always supplied as a complete, tested microwave cable assembly with defined and guaranteed radio frequency and mechanical values.

SUCOFLEX

is defined in the following way:

One standard assembly consists of the following items if no additional specifications are provided:

- Microwave cable specified
- Connectors specified
- Marking sleeve with serial number
- RF test protocol showing insertion and return losses

SUCOFLEX

provides an optimum solution to your microwave transmission problems.

SUCOFLEX

cables, connectors and assemblies are entirely developed, manufactured, tested and supplied by HUBER+SUHNER, your partners for flexible microwave cable assemblies.

SUCOFLEX

is a registered trade mark for microwave cable assemblies from HUBER+SUHNER AG.

Advantages of SUCOFLEX®

Test+Measurement



Wide range of connectors and ruggedisation

1.85mm, 2.4mm, 2.92mm, 3.5mm, SMA, BMA, QMA, QN, BNC, TNC, N, 716, PC7 and various ruggedisations

Electrical stability

Thanks to their special rotary swaged inner conductor design, types like SUCOFLEX 118, SUCOFLEX 126, SUCOFLEX 526, SUCOFLEX 540 and SUCOFLEX 550 are particularly phase stable when subjected to flexure.

High speed digital testing

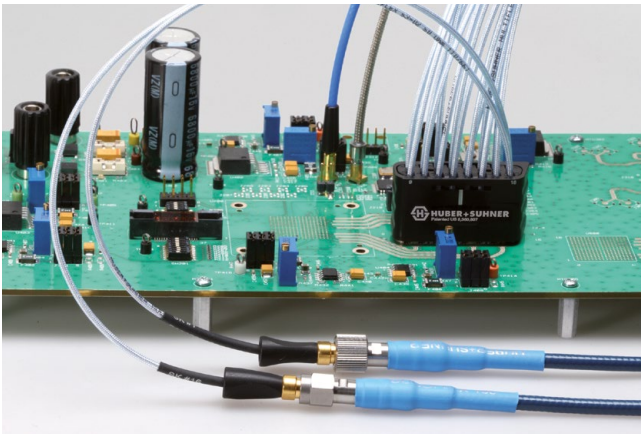

High speed digital chip verification

Lowest loss, best signal integrity, dense and space saving PCB connectivity, proven and tested solutions and components

High speed digital hardware and system verification

Multicoax PCB edge/panel mount solutions, customized solutions for Multicoax interconnectivity between systems and modules

Automated test equipment

Customized Multicoax interfaces at up to 90 GHz, Snap-on interfaces up to 67 GHz, cabling solutions optimized for highest data rates and frequencies.

Space



Perfect assembly technology

Assembly production for space applications in in-house clean room.

High reliability

Comprehensive series of MIL tests for verification of the out-standing specifications.

Advantages of SUCOFLEX®

Defense



Wide temperature range

-55 to +165 °C for most cable types
-55 to +125 °C for most connector types

Mechanical protection

A wide range of ruggedisations are available for most SUCOFLEX cable types.

Rugged connectors

Insulators and inner conductors fully captivated, patented connector assembly techniques.

High packing density

Easy connection and disconnection of up to 8 assemblies with multipoint connectors according to MIL-C-38999.

Naval



Chemical stability

Thanks to excellent materials (FEP) and inert surfaces.

High power performance

SUCOFLEX 106 with more than 400 W at 18 GHz CW power capability.

Halogen free

LSFH jackets for SUCOFLEX assemblies are available.

Airborne



Vibration stability

SUCOFLEX assemblies withstand vibrations involving accelerations up to 100 g without deterioration of their performance.

Low weight

Unit construction system use of aluminium core conductors for an optimised assembly design with SUCOFLEX 300.

Wide frequency range

SUCOFLEX from DC up to 40 GHz

Overview SUCOFLEX®

Cross reference within product range

Outer diameter (mm)	Cable attenuation at 18 GHz (dB/m)	Cables	Interfaces													
			QMA	QN	7/6	BMA	TNC	N	SMA	3.5mm	2.92mm (SK)	2.4mm	1.85mm	MMPX		
3,3	2,9	SUCOFLEX 570													70	67
3,7	2,0	SUCOFLEX 101								26,5						
3,7	3,0	SUCOFLEX 101_P								26,5						
3,7	2,0	SUCOFLEX 550								18	26,5	40	50			
4,0	1,7	SUCOFLEX 102				18	18					40	40			
4,0	1,7	SUCOFLEX 540										40	40			
4,6	1,3	SUCOFLEX 103				18	18	18	18	33	33					
5,5	1,1	SUCOFLEX 104	6	6		18	18	18	18							
5,4	1,2	SUCOFLEX 304								18						
5,5	1,1	SUCOFLEX 126			7,5	18	18	18	18							
5,5	1,1	SUCOFLEX 526							18	18	26,5					
7,9	0,8	SUCOFLEX 106	6	6	7,5		18	18	18							
7,9	0,8	SUCOFLEX 118			7,5		18	18	18							
9,0	0,3 (5,5 GHz)	SUCOFLEX 307						5,5								

 Frequency (GHz)

Summary of SUCOFLEX[®] qualifications

The entire SUCOFLEX family is certified to the following standards through testing, analysis or similarity.

Temperature, altitude and humidity

MIL-STD-810, method 518.1, procedure I

Thermal shock

MIL-STD-202, method 106, condition B1, 25 cycles, temperature: -54 to 125 °C

Mechanical shock

MIL-STD-810, method 516.3, procedure I (half-sine), 20 g, 6 to 9 ms, 45 Hz cross over frequency

MIL-STD-810, method 516, procedure I (saw-tooth), 40 g saw-tooth pulse of 11 ms duration 3 shocks in each of the six directions

Vibration

MIL-STD-810, method 519.3, procedure I, figure 514.3-1, (gunfire), 26.5 min. with specified vibration profile

MIL-STD-810, method 514.3, procedure I (random), functional: 0.2 g²/Hz, endurance: 0.83 g²/Hz

MIL-STD-202; method 204, condition G (sinusoidal), acceleration: 30 g, frequency range: 10 to 2000 Hz, duration: 4 hours in each of three axes

Acceleration

MIL-STD-810, method 513.3, procedure II, 27 g, 5 min.

MIL-STD-810, method 513.3, procedure I, 50 g, 5 min.

Chemical resistance

British standard 3G100, part 2, section 3, class A

Moisture resistance

MIL-STD-202, method 106, 10 day exposure

Salt fog

MIL-STD-810, method 509.2, 48 hours exposure to a 5 % solution

Fungus

MIL-STD-810, method 508.3

Sand and dust

Def. stand. 07-55, part 2, section 4, issue 1, +35 °C, 3 hours

Solar radiation

MIL-STD-810, method 505, procedure II

Overview SUCOFLEX® 100

The high performance microwave cable assembly

Product description

SUCOFLEX 100 series flexible microwave cable assemblies offer superior electrical and mechanical performance for static and dynamic applications. This series is a high-end product designed to provide optimal performance up to 40 GHz, where stringent electrical requirements – in particular stability and low loss – are important. Their mechanical and climate resistance properties surpass those of standard flexible cables. This cable type is used in aerospace and defence systems.

Product features

- The cable maintains stable electrical characteristics when exposed to bending and temperature, enabling reliable test results
- Excellent return- and insertion loss
- Can be provided with various ruggedisations to protect the assembly against different environmental influences
- Available as assembly only



Recommended connectors

SF_101	SMA
SF_102	SMA, N, TNC, 2,92mm (SK)
SF_103	SMA, BMA, N, TNC, 3,5mm, 2,92mm (SK)
SF_104 + SF_126	716, SMA, BMA, TNC, N,
SF_106 + SF_118	716, SMA, N, QN, TNC
	Other connectors available on request

Technical data

HUBER+SUHNER cable type	Operating frequency GHz	Temperature range		Outer diameter	Nominal atten. 18 GHz, 25°C (dB)	Bending radii		Weight (g)
		min. °C	max. °C			static (mm)	dynamic (mm)	
SUCOFLEX_101	26,5	-55	125	3,7	2,0	11	20	36
SUCOFLEX_101_P	26,5	-55	125	3,7	3,0	11	20	32
SUCOFLEX_102	40	-55	125	4	1,7	12	20	40
SUCOFLEX_102_D	40	-55	125	4,6	1,7	15	30	45
SUCOFLEX_102_I	40	-40	85	4	1,7	12	20	36
SUCOFLEX_103	33	-55	125	4,6	1,3	13	22	53
SUCOFLEX_103_D	33	-55	125	5,1	1,3	20	30	63
SUCOFLEX_103_I	33	-40	85	4,8	1,3	13	20	53
SUCOFLEX_104	26,5	-55	125	5,5	1,1	16	25	84
SUCOFLEX_104_D	26,5	-55	125	6,1	1,1	20	30	75
SUCOFLEX_104_I	26,5	-40	85	6,6	1,1	16	25	82
SUCOFLEX_126	26,5	-55	125	5,5	1,1	16	25	84
SUCOFLEX_126_D	26,5	-55	125	6,1	1,1	20	30	80
SUCOFLEX_106	18	-55	125	7,9	0,8	24	40	145
SUCOFLEX_106_D	18	-55	125	8,3	0,8	26	45	156
SUCOFLEX_106_I	18	-40	85	8,2	0,8	24	40	146
SUCOFLEX_118	18	-55	125	7,9	0,8	24	40	145
SUCOFLEX_118_D	18	-55	125	8,3	0,8	26	45	156
SUCOFLEX_118_I	18	-40	85	8,2	0,8	24	40	146

SUCOFLEX® 101 / 101_P

Product description

The SUCOFLEX 101 high end cable assemblies are designed to provide optimal performance up to 26.5 GHz where stringent electrical requirements – in particular stability and low loss, are important. Their mechanical and climate resistance properties surpass those of standard flexible cable.

Product features

- Impedance 50 Ω
- Applicable up to 26.5 GHz
- High stability and low loss

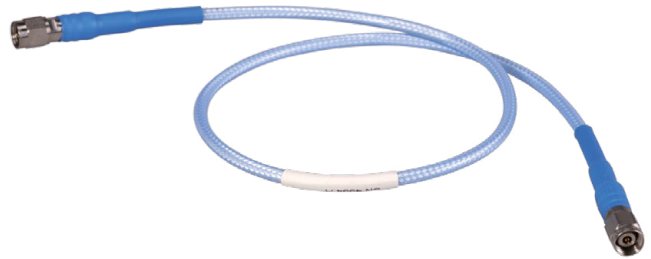

Recommended connectors

SF_101	SMA
SF_101_P	SMA
Other connectors available on request	

Construction

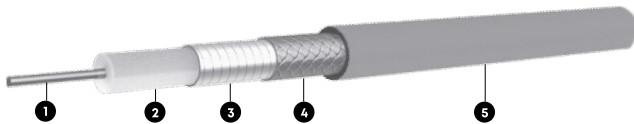

SF_101/101_P

Cable	Inner conductor ①	Dielectric ②	Outer conductor ③ ④	Jacket ⑤	Outer diameter (mm)
SUCOFLEX_101	CuAg wire	LD-PTFE	CuAg tape/braid	FEP, blue	3,7
SUCOFLEX_101_P	CuAg strand	LD-PTFE	CuAg tape/braid	FEP, blue	3,7

SUCOFLEX® 101 / 101_P

Assembly types

		SUCOFLEX_101	SUCOFLEX_101_P
Construction			
Max. operating frequency	GHz	26,5	26,5
Application		static	dynamic
Velocity of propagation	%	77	77
Weight		36	32
Min. bending radius static	mm	11	11
Min. bending radius repeated	mm	20	20
Temperature range	°C	-55 to +125	-55 to +125
Crush resistance	kN/m	8	8
Tensile load	N	100	100
Inner conductor		solid wire	stranded wire
Dielectric		LD-PTFE	LD-PTFE
Outer conductor		tape/braid	tape/braid
Jacket		FEP	FEP
Outer diameter	mm	3,7	3,7
Screening effectiveness (up to 18 GHz)	dB	> 90	> 90
Phase stability vs. flexure (360°, diameter 40 mm)	°el/GHz	< 1.2	< 0.9
Phase stability vs. temperature (-40 to +85 °C)	ppm	< 1500	< 1500
Assembly phase matching tolerances	°el/GHz	+/- 0.5	+/- 0.5
Cable attenuation at 25 °C	dB	see graph	see graph
Insertion loss stability vs. bending	dB	+/- 0.2	+/- 0.2
Insertion loss stability vs. temperature	%/°C	< 0.2	< 0.2
Insertion loss stability vs. shaking	dB	+/- 0.1	+/- 0.1
Power handling	watt	see graph	see graph

SUCOFLEX® 101 / 101_P

Attenuation (nominal values at +25 °C ambient temperature)

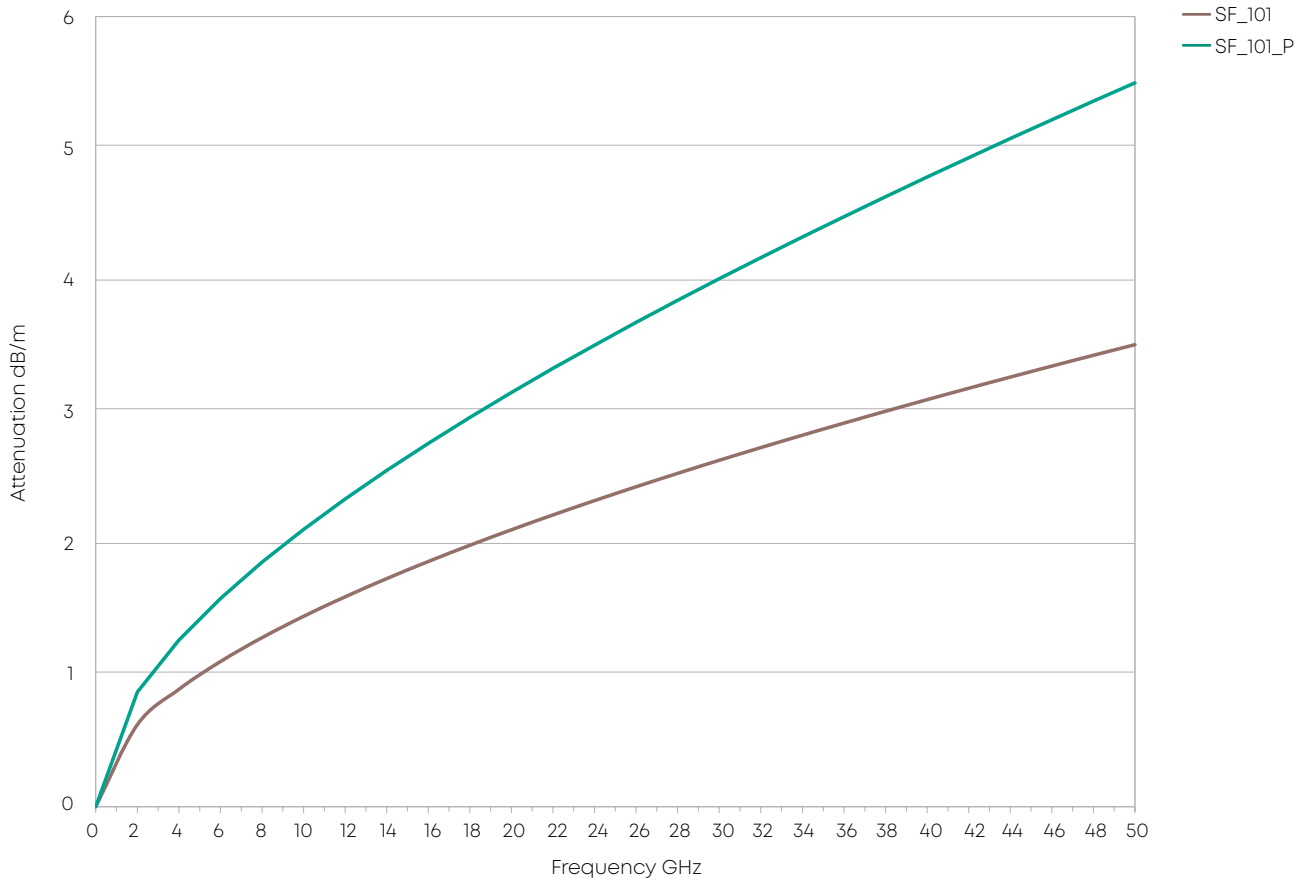

Power handling (maximum values at 25 °C ambient temperature and sea level)

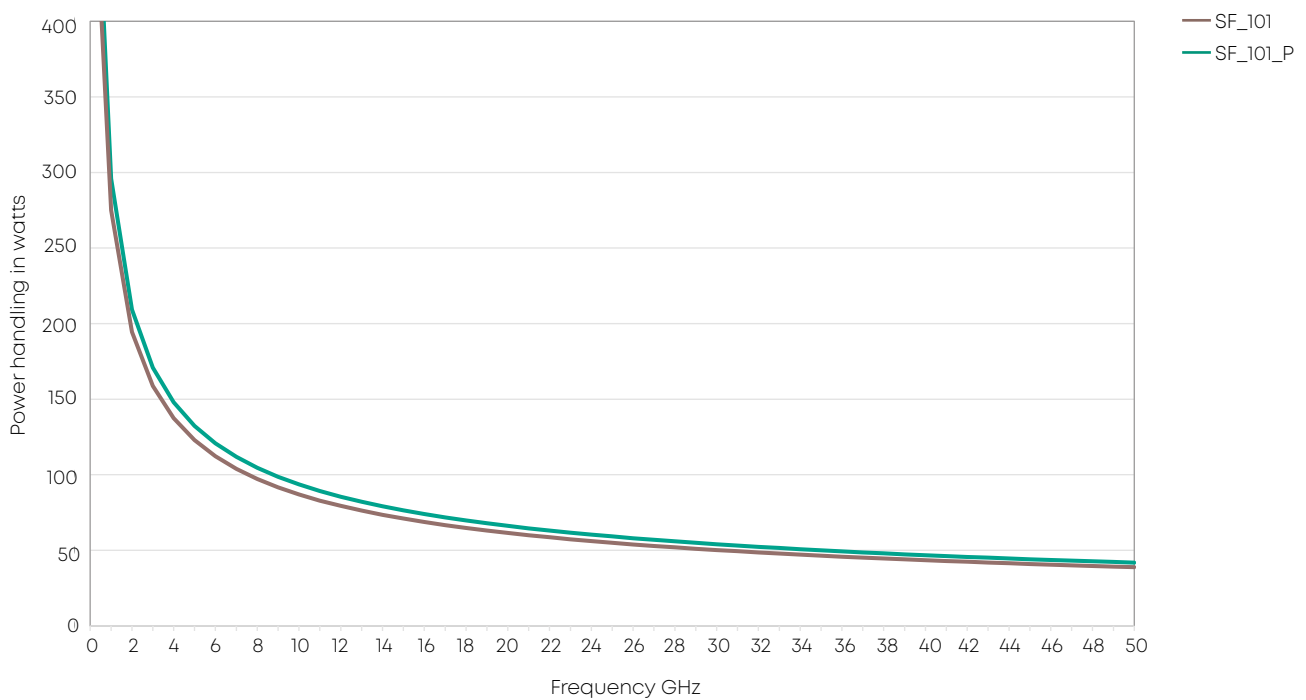

SUCOFLEX® 101 / 101_P

Available connectors

Connector	Series, pattern	HUBER+SUHNER connector type	SF 101	SF 101_P	Operating frequency (GHz)	VSWR per connector
SMA	straight cable plug	SF_11_SMA-153		•	26,5	1,2
	straight cable plug	SF_11_SMA-190	•		26,5	1,2

SUCOFLEX® 102

The high performance microwave cable assembly working up to 40 GHz

Product description

SUCOFLEX 102 are ideal for applications up to 40 GHz or wherever the weight or the diameter are the critical factors to be taken into account. The connectors mainly used here are SK, SMA, N and TNC. Typical applications are aircraft manufacture.

Product features

- Impedance 50 Ω
- Applicable up to 40 GHz
- High stability and low loss



Recommended connectors

SF_102, 102_D	SK, SMA, N, TNC
	Other connectors available on request

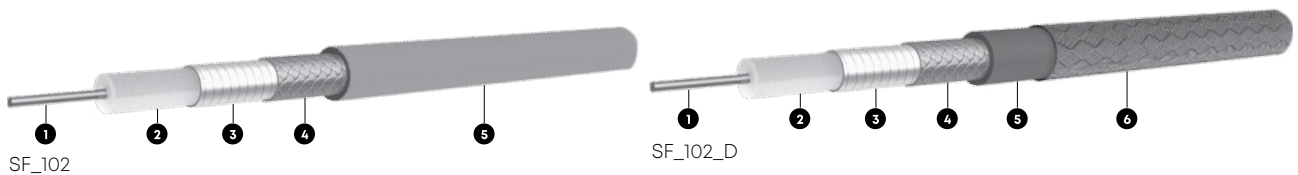

Construction



Cable	Inner conductor 1	Dielectric 2	Outer conductor 3 4	Jacket 5	Ruggedisation 6	Outer diameter mm
SUCOFLEX_102	CuAg wire	LD-PTFE	CuAg tape/braid	FEP, blue		4,0
SUCOFLEX_102_D	CuAg wire	LD-PTFE	CuAg tape/braid	FEP, blue	aramid yarn braid, blue	4,6

SUCOFLEX® 102

Assembly types

		SUCOFLEX_102	SUCOFLEX_102_D
Construction			
Max. operating frequency	GHz	40	40
Application		static	static
Velocity of propagation	%	77	77
Weight		40	45
Min. bending radius static	mm	12	15
Min. bending radius repeated	mm	20	30
Temperature range	°C	-55 to +125	-55 to +125
Crush resistance	kN/m	8	8
Tensile load	N	150	150
Inner conductor		solid wire	solid wire
Dielectric		LD-PTFE	LD-PTFE
Outer conductor		tape/braid	tape/braid
Jacket		FEP	FEP
Outer diameter	mm	4,0	4,6
Screening effectiveness (up to 18 GHz)	dB	> 90	> 90
Phase stability vs. flexure (360°, diameter 40 mm)	°el/GHz	< 1.2	< 1.2
Phase stability vs. temperature (-40 to +85 °C)	ppm	< 1500	< 1500
Assembly phase matching tolerances	°el/GHz	+/- 0.5	+/- 0.5
Cable attenuation at 25 °C	dB	see graph	see graph
Insertion loss stability vs. bending	dB	+/- 0.2	+/- 0.2
Insertion loss stability vs. temperature	%/°C	< 0.2	< 0.2
Insertion loss stability vs. shaking	dB	+/- 0.1	+/- 0.1
Power handling	watt	see graph	see graph

SUCOFLEX® 102

Attenuation (nominal values at +25 °C ambient temperature)

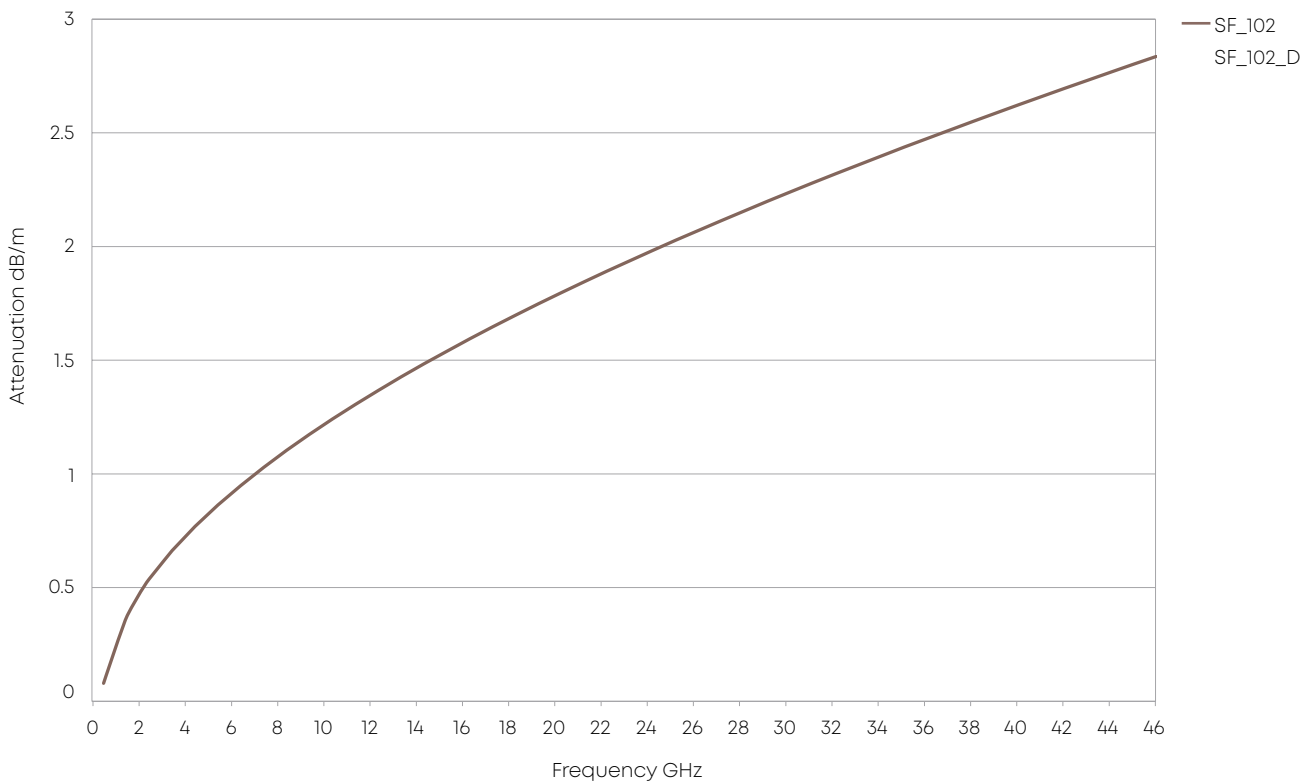

Power handling (maximum values at 25 °C ambient temperature and sea level)

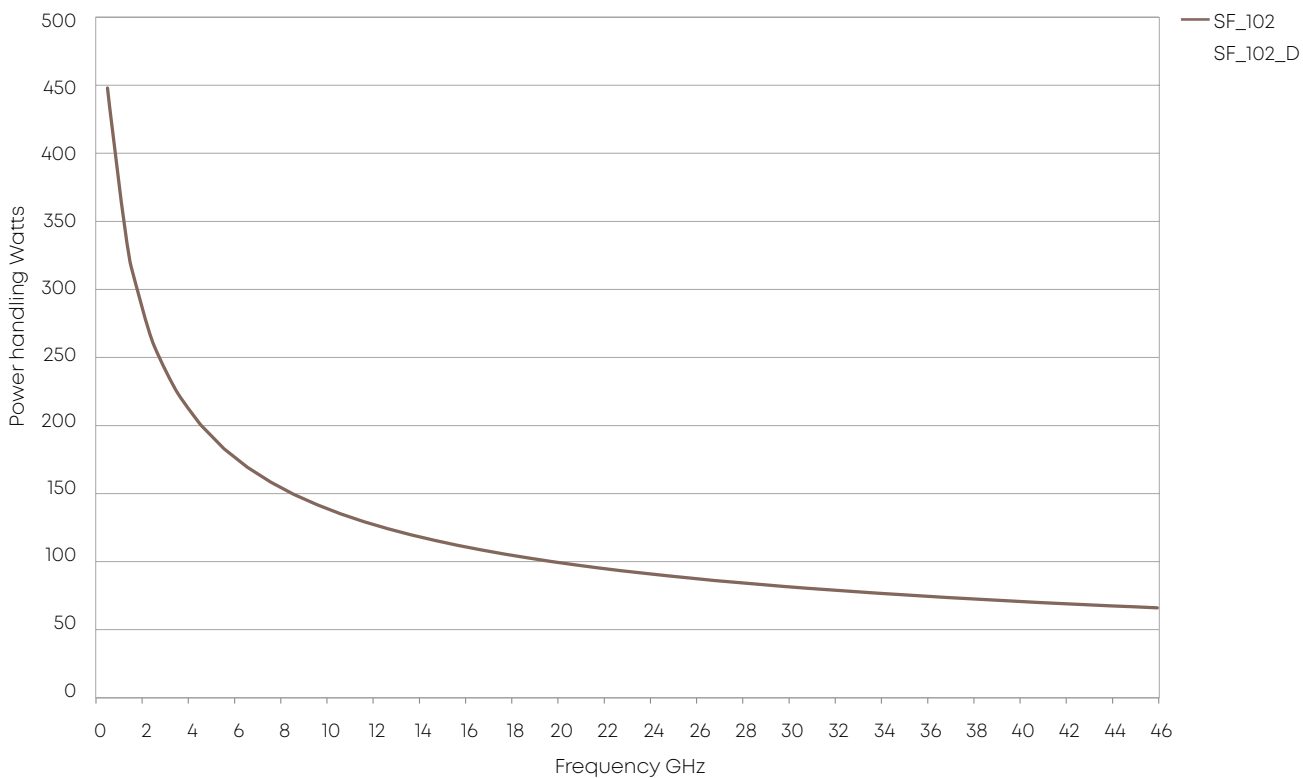

SUCOFLEX® 102

Available connectors

Connector	Series, pattern	HUBER+SUHNER connector type	SF_102	SF_102_D	Operating frequency (GHz)	VSWR per connector	Remarks
SK	straight cable plug	SF_11_SK-252	•	•	40	1,2	
	right angle cable plug	SF_16_SK-252	•	•	40	1,2	
	straight panel bulkhead cable jack	SF_24_SK-251	•	•	40	1,2	ML 35
N	straight cable plug	SF_11_N-206	•	•	18	1,12	
SMA	straight cable plug	SF_11_SMA-218	•	•	18 26,5	1,12 1,20	
	right angle cable plug	SF_16_SMA-254	•	•	18	1,12	
	straight cable jack	SF_21_SMA-204	•	•	18 26,5	1,12 1,20	
	straight panel bulkhead cable jack	SF_24_SMA-210	•	•	18 26,5	1,12 1,20	ML 20
TNC	straight cable plug	SF_11_TNC-222	•	•	18	1,12	
	straight panel bulkhead cable jack	SF_24_TNC-222	•	•	18	1,12	ML 4

SUCOFLEX® 103

The high performance microwave cable assembly working up to 33 GHz

Product description

SUCOFLEX 103 is the ideal solution for systems in which the attenuation to weight ratio is very important. Different ruggedisations and a large number of the common connector types complete this range.

Product features

- Impedance 50 Ω
- Applicable up to 33 GHz
- High stability and low loss



Recommended connectors

SF_103	SMA, BMA, BNC, PC3.5, N, TNC
	Other connectors available on request

Construction

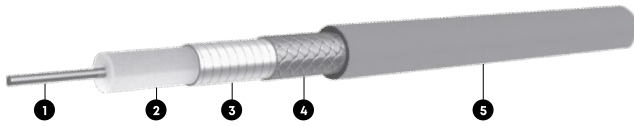

SF_103/103_E

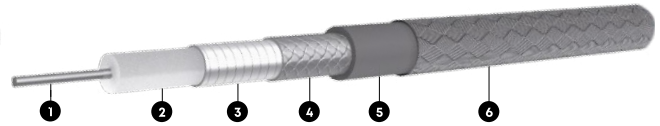

SF_103_D

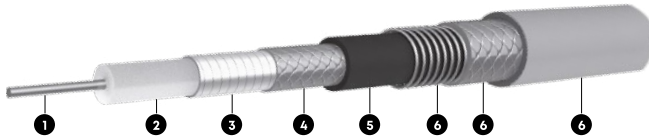



SF_103_EA

Cable	Inner conductor ①	Dielectric ②	Outer conductor ③ ④	Jacket ⑤	Ruggedisation ⑥	Outer diameter mm
SUCOFLEX_103	CuAg wire	LD-PTFE	CuAg tape/braid	FEP, blue		4,6
SUCOFLEX_103_E	CuAg wire	LD-PTFE	CuAg tape/braid	PUR, blue		4,6
SUCOFLEX_103_D	CuAg wire	LD-PTFE	CuAg tape/braid	FEP, blue	aramid yarn braid, blue	5,1
SUCOFLEX_103_EA	CuAg wire	LD-PTFE	CuAg tape/braid	PUR, blue	stainless steel, PUR, blue or black	10,3

SUCOFLEX® 103

Assembly types

		SUCOFLEX_103	SUCOFLEX_103_E	SUCOFLEX_103_D	SUCOFLEX_103E_A
Construction					
Max. operating frequency	GHz	33	33	33	33
Application		static	static	static	static
Velocity of propagation	%	77	77	77	77
Weight	g/m	53	52	63	142
Min. bending radius static	mm	13	13	20	30
Min. bending radius repeated	mm	22	22	30	50
Temperature range	°C	-55 to +125	-40 to +85	-55 to +125	-40 to +85
Crush resistance	kN/m	8	8	8	80
Tensile load	N	200	200	200	400
Inner conductor		solid wire	solid wire	solid wire	solid wire
Dielectric		LD-PTFE	LD-PTFE	LD-PTFE	LD-PTFE
Outer conductor		tape/braid	tape/braid	tape/braid	tape/braid
Jacket		FEP	PUR	FEP	PUR
Ruggedisation		no	no	aramid yarn braid	stainless steel/PUR
Outer diameter	mm	4.6	4.6	5.1	10.3
Screening effectiveness (up to 18 GHz)	dB	> 90	> 90	> 90	> 90
Phase stability vs. flexure (360°, diameter 55 mm)	°el/GHz	< 1.4	< 1.4	< 1.4	< 1.4
Phase stability vs. temperature (-40 to +85 °C)	ppm	< 1500	< 1500	< 1500	< 1500
Assembly phase matching tolerances	°el/GHz	± 0.5	± 0.5	± 0.5	± 0.5
Cable attenuation at 25 °C	dB/m	see graph	see graph	see graph	see graph
Insertion loss stability vs. bending	dB	± 0.2	± 0.2	± 0.2	± 0.2
Insertion loss stability vs. temperature	%/°C	< 0.2	< 0.2	< 0.2	< 0.2
Insertion loss stability vs. shaking	dB	± 0.1	± 0.1	± 0.1	± 0.1
Power handling	watt	see graph	see graph	see graph	see graph

SUCOFLEX® 103

Attenuation (nominal values at +25 °C ambient temperature)

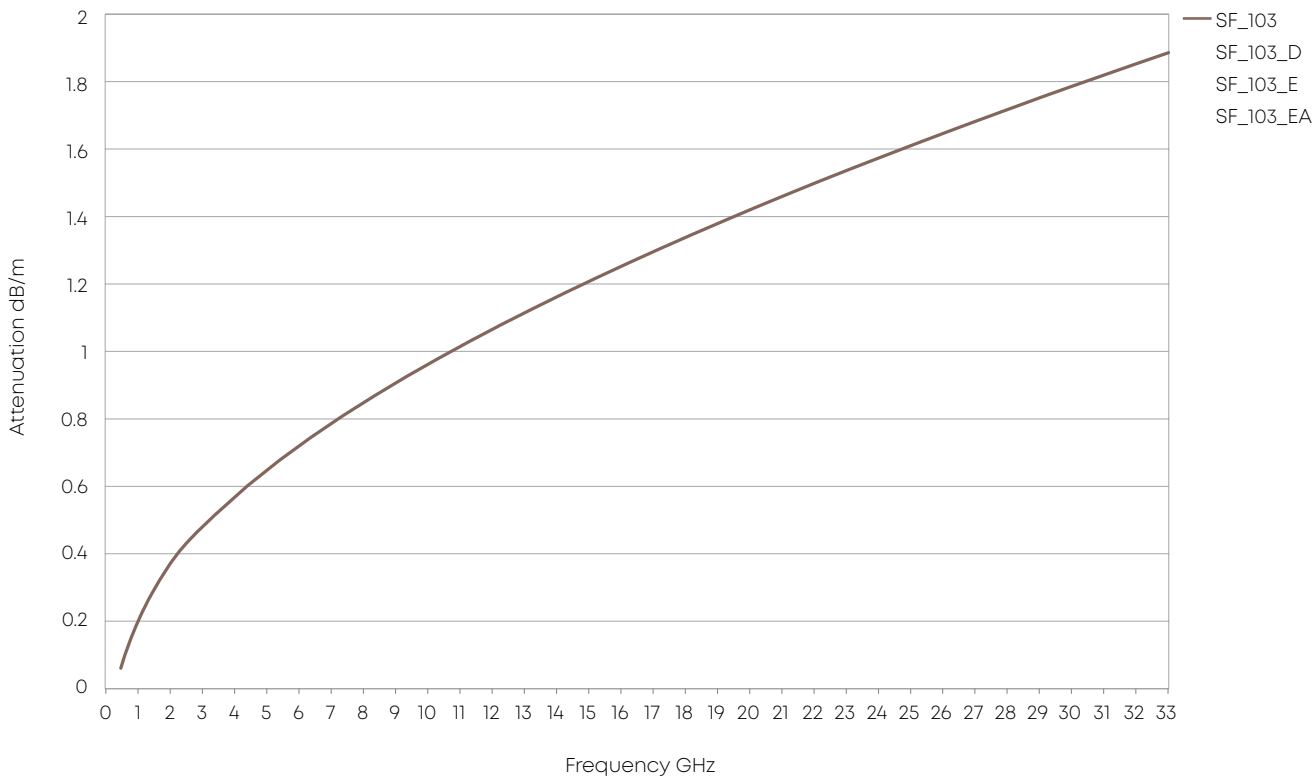

Power handling (maximum values at 25 °C ambient temperature and sea level)

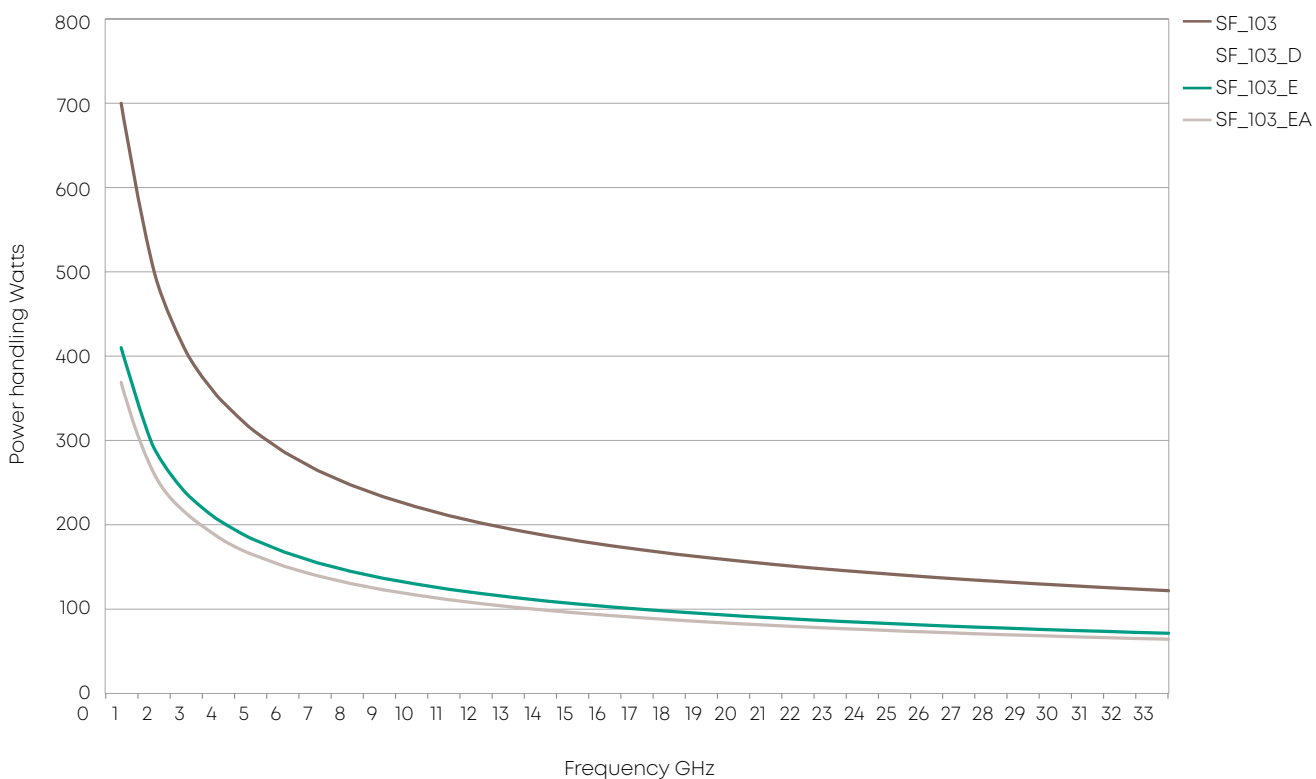

SUCOFLEX® 103

Available connectors

Connector	Series, pattern	HUBER+SUHNER connector type	SF 103 SF 103_E	SF 103_D	Operating frequency (GHz)	VSWR per connector	Remarks
BNC	straight cable plug	SF_11_BNC-373	•	•	4	1,14	
N	straight cable plug	SF_11_N-371	•	•	18	1,12	
	right angle cable plug	SF_16_N-372	•	•	18	1,12	swept
	straight panel bulkhead cable jack	SF_24_N-352	•	•	18	1,12	ML12
SMA	straight cable plug	SF_11_SMA-371	•	•	18	1,12	
	right angle cable plug	SF_16_SMA-371	•	•	18	1,12	
	straight cable jack	SF_21_SMA-372	•	•	18	1,12	
PC 3.5	straight cable plug	SF_11_PC35-31	•	•	26,5	1,16	
	straight cable jack	SF_21_PC35-31	•	•	26,5	1,16	
TNC	straight cable plug	SF_11_TNC-353	•	•	18	1,12	
	right angle cable plug	SF_16_TNC-373	•	•	18	1,12	swept
	straight panel bulkhead cable jack	SF_24_TNC-353	•	•	18	1,12	ML4

SUCOFLEX® 104

The high performance microwave cable assembly working up to 26.5 GHz

Product description

SUCOFLEX 104 cables that can be universally assembled with the widest range of connector types.

Product features

- Impedance 50 Ω
- Applicable up to 26.5 GHz
- High stability and low loss



Recommended connectors

SF_104	SMA, BMA, BNC, N, TNC
	Other connectors available on request

Construction

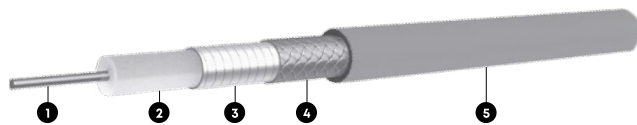

SF 104/104E

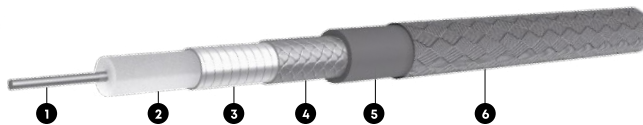



SF 104D

Cable	Inner conductor ①	Dielectric ②	Outer conductor ③ ④	Jacket ⑤	Ruggedisation ⑥	Outer diameter mm
SUCOFLEX_104	CuAg wire	LD-PTFE	CuAg tape/braid	FEP, blue		5,5
SUCOFLEX_104_E	CuAg wire	LD-PTFE	CuAg tape/braid	PUR, blue		5,5
SUCOFLEX_104_D	CuAg wire	LD-PTFE	CuAg tape/braid	FEP, blue	aramid yarn braid, blue	6,1

SUCOFLEX® 104

Assembly types

		SUCOFLEX_104	SUCOFLEX_104_E	SUCOFLEX_104_D
Construction				
Max. operating frequency	GHz	26.5	26.5	26.5
Application		static	static	static
Velocity of propagation	%	77	77	77
Weight	g/m	73	65	96
Min. bending radius static	mm	16	16	20
Min. bending radius repeated	mm	25	25	30
Temperature range	°C	-55 to +125	-40 to +85	-55 to +125
Crush resistance	kN/m	8	8	8
Tensile load	N	250	250	250
Inner conductor		solid wire	solid wire	solid wire
Dielectric		LD-PTFE	LD-PTFE	LD-PTFE
Outer conductor		tape/braid	tape/braid	tape/braid
Jacket		FEP	PUR	FEP
Ruggedisation		no	no	aramid yarn braid
Outer diameter	mm	5.5	5.5	6.1
Screening effectiveness (up to 18 GHz)	dB	> 90	> 90	> 90
Phase stability vs. flexure (360°, diameter 55 mm)	°el/GHz	< 1.7	< 1.7	< 1.7
Phase stability vs. temperature (-40 to +85 °C)	ppm	< 1500	< 1500	< 1500
Assembly phase matching tolerances	°el/GHz	± 0.5	± 0.5	± 0.5
Cable attenuation at 25 °C	dB/m	see graph	see graph	see graph
Insertion loss stability vs. bending	dB	± 0.2	± 0.2	± 0.2
Insertion loss stability vs. temperature	%/°C	< 0.2	< 0.2	< 0.2
Insertion loss stability vs. shaking	dB	± 0.1	± 0.1	± 0.1
Power handling	watt	see graph	see graph	see graph

SUCOFLEX® 104

Attenuation (nominal values at +25 °C ambient temperature)

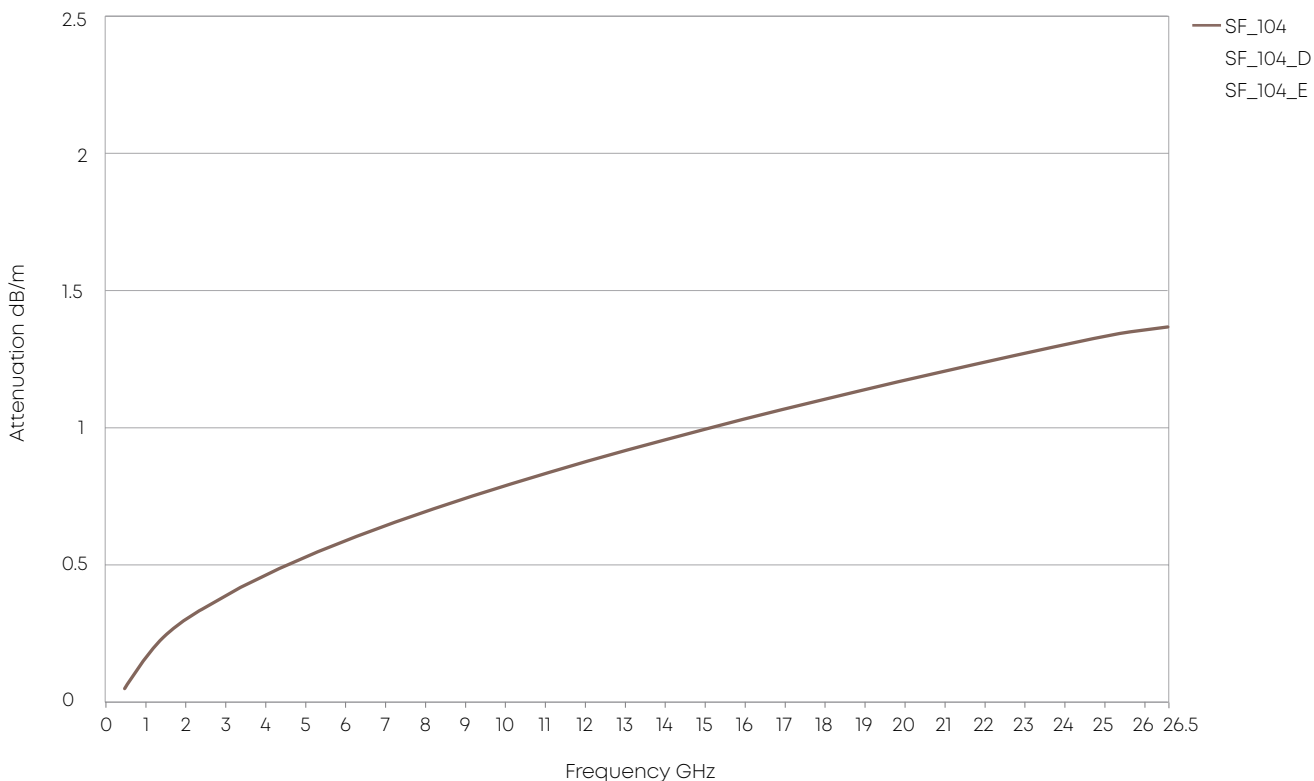

Power handling (maximum values at 25 °C ambient temperature and sea level)

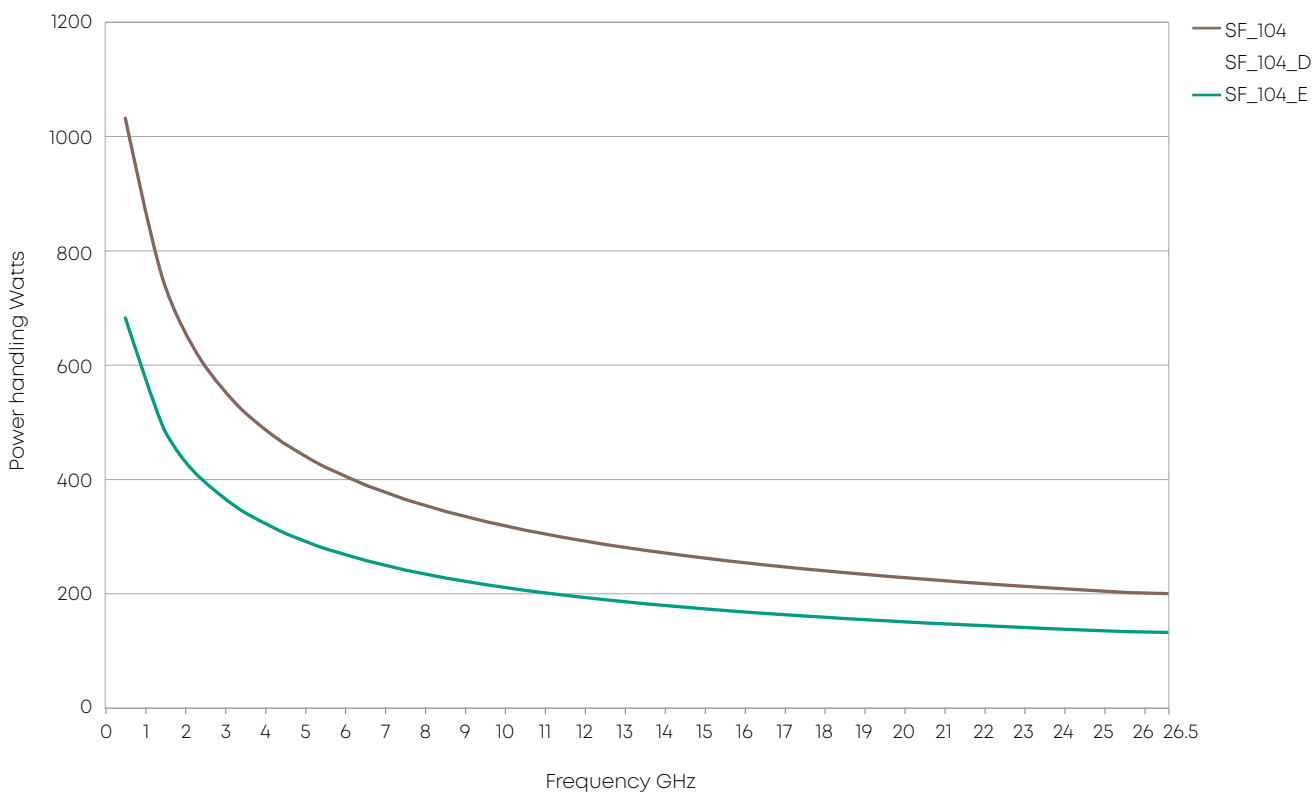

SUCOFLEX® 104

Available connectors

Connector	Series, pattern	HUBER+SUHNER connector type	SF_104 SF_104_E	SF_104_D	Operating frequency GHz	VSWR per connector	Remarks
BMA	straight bulkhead cable plug	SF_14_BMA-403	•	•	18	1,12	Multiport / MIL-C-38999
	straight panel bulkhead cable jack	SF_24_BMA-401	•	•	18	1,12	Multiport / MIL-C-38999
BNC	straight cable plug	SF_11_BNC-451	•	•	4	1,14	
N	straight cable plug	SF_11_N-451	•	•	18	1,12	Combi nut
	straight cable plug	SF_11_N-477	•	•	15	1,12	High salt resistant (SS316L), hexagonal nut with safety holes
					18	1,16	
	right angle cable plug	SF_16_N-45	•	•	12,4	1,14	High salt resistant (SS316L), hexagonal nut with safety holes
					18	1,18	
straight cable jack	SF_21_N-451	•	•	18	1,12		
straight panel bulkhead cable jack	SF_24_N-451	•	•	18	1,12	High salt resistant (SS316L), hexagonal nut with safety holes (ML12)	
SMA	straight cable plug	SF_11_SMA-451	•	•	18	1,12	
	straight cable plug	11 SMA-50-4-56	•	•	18	1,12	High salt resistant (SS316L), hexagonal nut with safety holes
	right angle cable plug	SF_16_SMA-497	•	•	18	1,12	High salt resistant (SS316L), hexagonal nut with safety holes
	straight cable jack	SF_21_SMA-451	•	•	18	1,12	
	straight panel bulkhead cable jack	SF_24_SMA-451	•	•	18	1,12	ML35
TNC	straight cable plug	SF_11_TNC-457	•	•	18	1,12	High salt resistant (SS316L), hexagonal nut with safety holes
	right angle cable plug	SF_16_TNC-454	•	•	18	1,12	High salt resistant (SS316L), hexagonal nut with safety holes
	straight panel bulkhead cable jack	SF_24_TNC-457	•	•	18	1,12	High salt resistant (SS316L), hexagonal nut with safety holes (ML4)

SUCOFLEX® 126

The low loss, phase stable assembly up to 26.5 GHz

Product description

Where low loss, combined with excellent phase and amplitude stability is required, SUCOFLEX_126 must be applied.

Product features

- Impedance 50 Ω
- Applicable up to 26.5 GHz
- Excellent return loss, phase and amplitude stability
- Low loss
- Wide range of connectors



Recommended connectors

SF_126	SMA, BNC, N, TNC
	Other connectors available on request

Construction

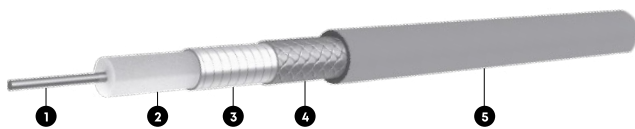

SF_126/126_E

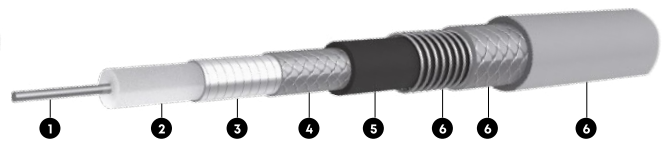

SF_126_EA

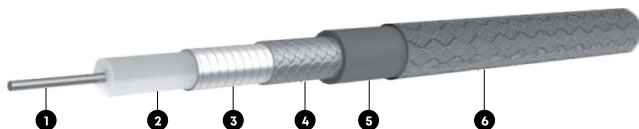





SF_126_D

Cable	Inner conductor ①	Dielectric ②	Outer conductor ③④	Jacket ⑤	Ruggedisation ⑥	Outer diameter mm
SUCOFLEX_126	CuAg low loss wire	LD-PTFE	CuAg tape/braid	FEP, blue		5.5
SUCOFLEX_126_E	CuAg low loss wire	LD-PTFE	CuAg tape/braid	PUR, blue		5.5
SUCOFLEX_126_D	CuAg low loss wire	LD-PTFE	CuAg tape/braid	FEP, blue	aramid yarn braid, blue	6.1
SUCOFLEX_126_EA	CuAg low loss wire	LD-PTFE	CuAg tape/braid	PUR, blue	stainless steel / PUR blue or black	10.3

SUCOFLEX® 126

Assembly types

		SUCOFLEX_126	SUCOFLEX_126_E	SUCOFLEX_126_D	SUCOFLEX_126_EA
Construction					
Max. operating frequency	GHz	26,5	26,5	26,5	26,5
Application		dynamic	dynamic	dynamic	dynamic
Velocity of propagation	%	77	77	77	77
Weight		70	66	80	171
Min. bending radius static	mm	16	16	20	30
Min. bending radius repeated	mm	25	25	30	50
Temperature range	°C	-55 to +125	-40 to +85	-55 to +125	-40 to +85
Crush resistance	kN/m	8	8	8	80
Tensile load	N	250	250	250	500
Inner conductor		stranded - low loss	stranded - low loss	stranded - low loss	stranded - low loss
Dielectric		LD-PTFE	LD-PTFE	LD-PTFE	LD-PTFE
Outer conductor		tape/braid	tape/braid	tape/braid	tape/braid
Jacket		FEP	PUR	FEP	PUR
Ruggedisation		no	no	aramid yarn	stainless steel/PUR
Outer diameter	mm	5,5	5,5	6,1	10,3
Screening effectiveness (up to 18 GHz)	dB	> 90	> 90	> 90	> 90
Phase stability vs. flexure (360°, diameter 40 mm)	°el/ GHz	< 0.9	< 0.9	< 0.9	< 0.9
Phase stability vs. temperature (-40 to +85 °C)	ppm	< 1500	< 1500	< 1500	< 1500
Assembly phase matching tolerances	°el/ GHz	+/- 0.5	+/- 0.5	+/- 0.5	+/- 0.5
Cable attenuation at 25 °C	dB	see graph	see graph	see graph	see graph
Insertion loss stability vs. bending	dB	+/- 0.2	+/- 0.2	+/- 0.2	+/- 0.2
Insertion loss stability vs. temperature	%/°C	< 0.2	< 0.2	< 0.2	< 0.2
Insertion loss stability vs. shaking	dB	+/- 0.1	+/- 0.1	+/- 0.1	+/- 0.1
Power handling	watt	see graph	see graph	see graph	see graph

SUCOFLEX® 126

Attenuation (nominal values at +25 °C ambient temperature)

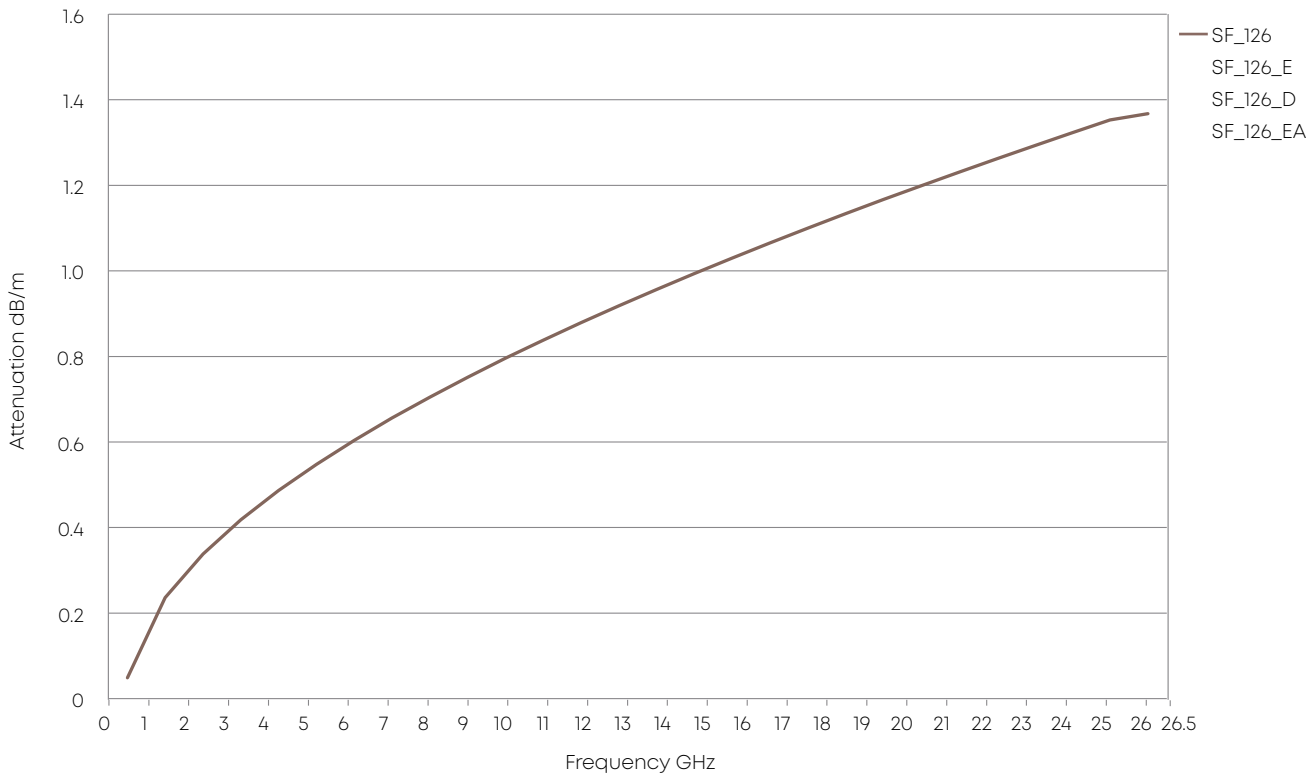

Power handling (maximum values at 25 °C ambient temperature and sea level)

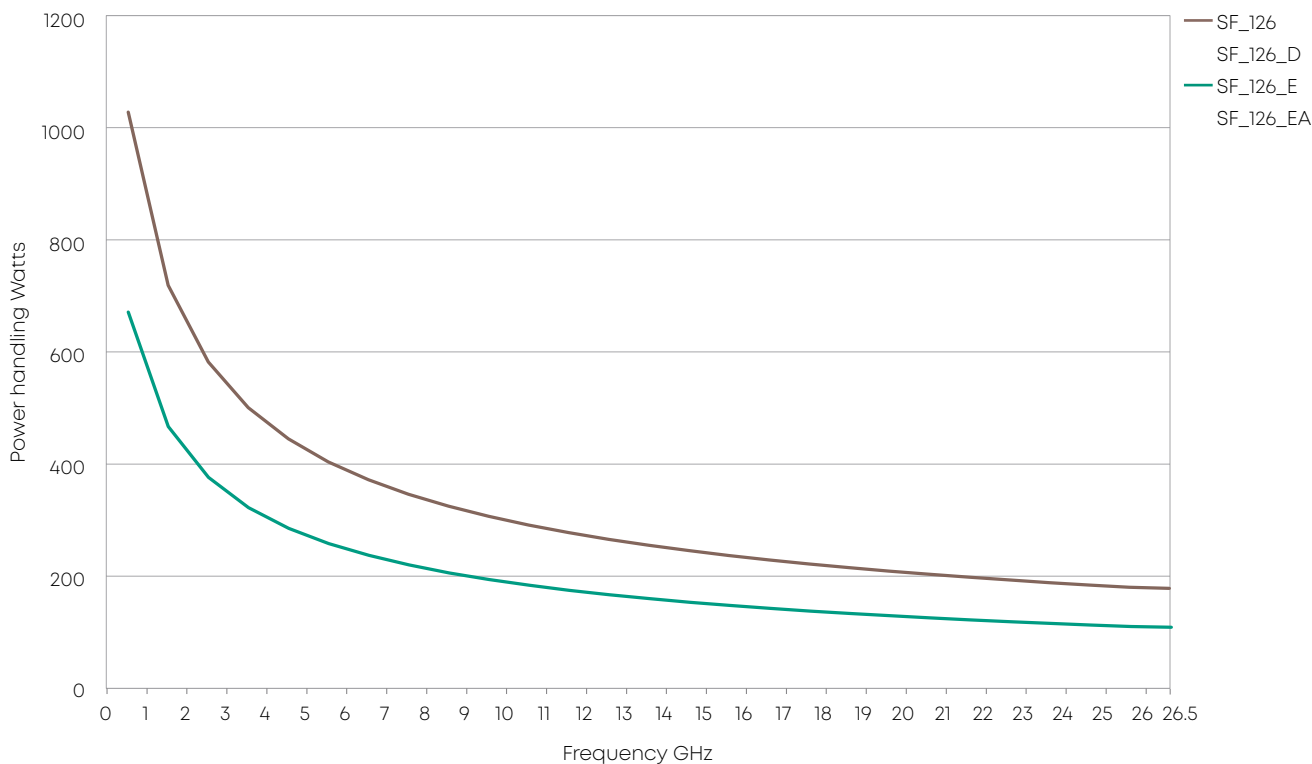

SUCOFLEX® 126

Available connectors

Connector	Series, pattern	HUBER+SUHNER connector type	SF126 SF126E	SF126EA	Operating frequency (GHz)	VSWR per connector	Remarks
BNC	Straight cable plug	SF_11_BNC-452	•	•	4,0	1,14	
N	Straight cable plug	SF_11_N-452	•	•	18	1,12	
	Straight cable plug	SF_11_N-477	•	•	15 18	1,12 1,16	High salt resistant (SS316L), hexagonal nut with safety holes
	Right angle cable plug	SF_16_N-457	•	•	12,4 18	1,14 1,18	
	Right angle cable plug	SF_16_N-458	•	•	12,4 18	1,14 1,18	High salt resistant (SS316L), hexagonal nut with safety holes
	Straight cable jack	SF_21_N-452	•	•	18	1,12	
	Straight panel bulkhead cable jack	SF_24_N-452	•	•	18	1,12	High salt resistant (SS316L), hexagonal nut with safety holes, mounting hole size 12
SMA	Straight cable plug	SF_11_SMA-451	•	•	18	1,12	
	Straight cable plug	SF_11_SMA-456	•	•	18	1,12	High salt resistant (SS316L), hexagonal nut with safety holes
	Right angle cable plug	SF_16_SMA-452	•	•	18	1,12	
	Straight cable jack	SF_21_SMA-451	•	•	18	1,12	
	Straight panel bulkhead cable jack	SF_24_SMA-451	•	•	18	1,12	mounting hole size 35
TNC	Straight cable plug	SF_11_TNC-456	•	•	18	1,12	
	Straight cable plug	SF_11_TNC-481	•	•	18	1,12	High salt resistant (SS316L), hexagonal nut with safety holes
	Right angle cable plug	SF_16_TNC-460	•	•	12,4 18	1,14 1,18	High salt resistant (SS316L), hexagonal nut with safety holes
	Straight panel bulkhead cable jack	SF_24_TNC-456	•	•	18	1,12	High salt resistant (SS316L), hexagonal nut with safety holes, mounting hole size 4

SUCOFLEX® 106 / 118

The high performance microwave cable assembly working up to 18 GHz

Product description

SUCOFLEX 106 and 118 are used in applications where special consideration must be given to low attenuation or high power handling capacity. Wherever phase stability is additionally demanded, the suitable type is the SUCOFLEX 118.

Most ruggedisations can be used in conjunction with these cables, and also the main connector series.

Product features

- Impedance 50 Ω
- Applicable up to 18 GHz
- High stability and low loss
- Wide range of connectors
- Further ruggedisations on request



Recommended connectors

SF_106 / 118	SMA, N, TNC, 716
	Other connectors available on request

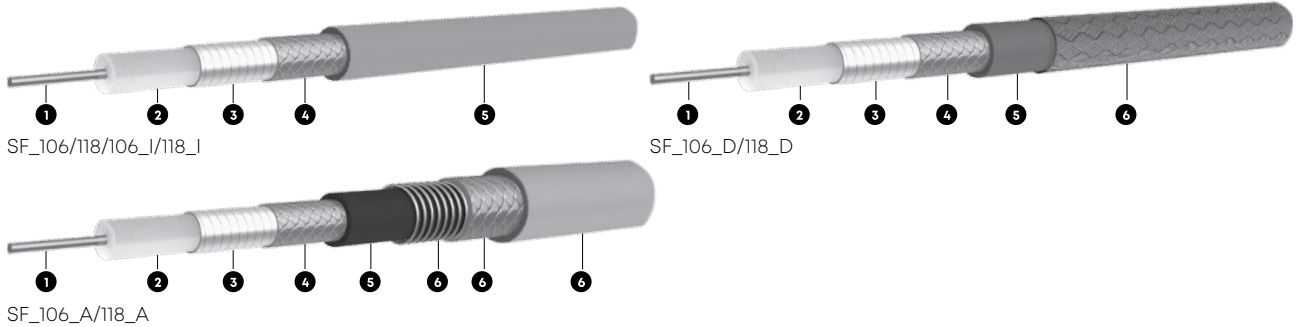

Construction



Cable	Inner conductor ①	Dielectric ②	Outer conductor ③ ④	Jacket ⑤	Ruggedisation ⑥	Outer diameter mm
SUCOFLEX_106	CuAg wire	LD-PTFE	CuAg tape/braid	FEP, blue		7,9
SUCOFLEX_106_A	CuAg wire	LD-PTFE	CuAg tape/braid	FEP, blue	stainless steel/ PUR black	13,2
SUCOFLEX_106_D	CuAg wire	LD-PTFE	CuAg tape/braid	FEP, blue	aramid yarn braid, blue	8,3
SUCOFLEX_106_I	CuAg wire	LD-PTFE	CuAg tape/braid	LSFH, black		8,2
SUCOFLEX_118	CuAg strand low loss	LD-PTFE	CuAg tape/braid	FEP, blue		7,9
SUCOFLEX_118_A	CuAg strand low loss	LD-PTFE	CuAg tape/braid	FEP, blue	stainless steel/ PUR black	13,2
SUCOFLEX_118_D	CuAg strand low loss	LD-PTFE	CuAg tape/braid	FEP, blue	aramid yarn braid, blue	8,3
SUCOFLEX_118_I	CuAg strand low loss	LD-PTFE	CuAg tape/braid	LSFH, black		8,2

SUCOFLEX® 106 / 118

Assembly types

		SUCOFLEX 106	SUCOFLEX 106I	SUCOFLEX 118	SUCOFLEX 118I	SUCOFLEX 106D	SUCOFLEX 118D	SUCOFLEX 106A	SUCOFLEX 118A
Construction									
Max. operating frequency	GHz	18	18	18	18	18	18	18	18
Application		static	static	dynamic	dynamic	static	dynamic	static	dynamic
Velocity of propagation	%	77	77	77	77	77	77	77	77
Weight	g/m	145	146	145	146	157	157	224	224
Min. bending radius static	mm	24	24	24	24	26	26	50	50
Min. bending radius repeated	mm	40	40	40	40	45	45	70	70
Temperature range	°C	-55 to +125	-40 to +85	-55 to +125	-40 to +85	-55 to +125	-55 to +125	-40 to +85	-40 to +85
Crush resistance	kN/m	12	12	12	12	12	12	60	60
Tensile load	N	400	400	400	400	400	400	400	400
Inner conductor		solid wire	solid wire	strand - low loss	strand - low loss	solid wire	strand - low loss	solid wire	strand - low loss
Dielectric		LD-PTFE	LD-PTFE	LD-PTFE	LD-PTFE	LD-PTFE	LD-PTFE	LD-PTFE	LD-PTFE
Outer conductor		tape/ braid	tape/ braid	tape/ braid	tape/ braid	tape/ braid	tape/ braid	tape/ braid	tape/ braid
Jacket		FEP	LSFH	FEP	LSFH	FEP	FEP	FEP	FEP
Ruggedisation		no	no	no	no	aramid yarn braid	aramid yarn braid	stainless steel/PUR	stainless steel/PUR
Outer diameter	mm	7.9	8.2	7.9	8.2	8.3	8.3	13.2	13.2
Screening effectiveness (up to 18 GHz)	dB	> 90	> 90	> 90	> 90	> 90	> 90	> 90	> 90
Phase stability vs. flexure (360°, diameter 85 mm)	°el/ GHz	< 2.0	< 2.0	< 1.2	< 1.2	< 2.0	< 1.2	< 2.0	< 1.2
Phase stability vs. temperature (-40 to +85 °C)	ppm	< 1500	< 1500	< 1500	< 1500	< 1500	< 1500	< 1500	< 1500
Assembly phase matching tolerances	°el/ GHz	± 0.5	± 0.5	± 0.5	± 0.5	± 0.5	± 0.5	± 0.5	± 0.5
Cable attenuation at 25 °C	dB/m	see graph	see graph	see graph	see graph	see graph	see graph	see graph	see graph
Insertion loss stability vs. bending	dB	± 0.2	± 0.2	± 0.2	± 0.2	± 0.2	± 0.2	± 0.2	± 0.2
Insertion loss stability vs. temperature	%/°C	< 0.2	< 0.2	< 0.2	< 0.2	< 0.2	< 0.2	< 0.2	< 0.2
Insertion loss stability vs. shaking	dB	± 0.1	± 0.1	± 0.1	± 0.1	± 0.1	± 0.1	± 0.1	± 0.1
Power handling	watt	see graph	see graph	see graph	see graph	see graph	see graph	see graph	see graph

SUCOFLEX® 106 / 118

Attenuation (nominal values at +25 °C ambient temperature)

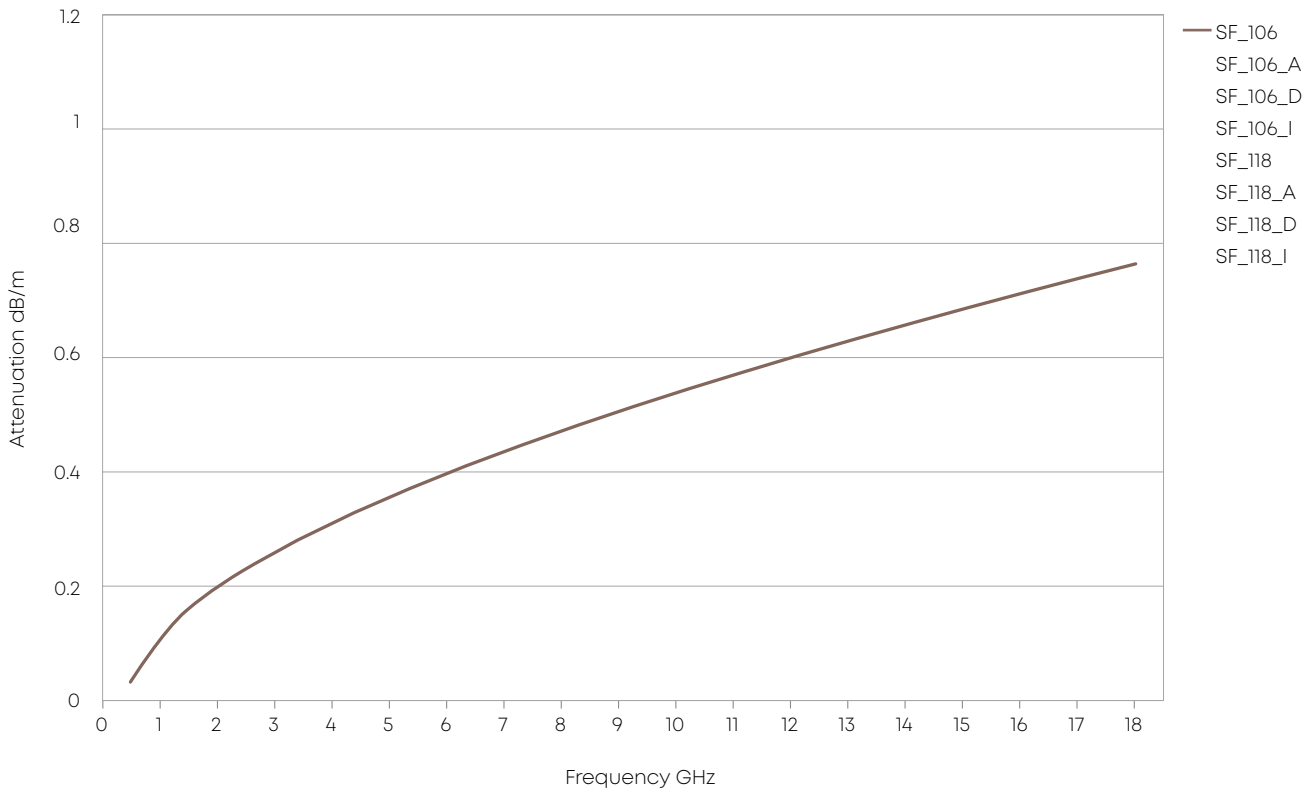

Power handling (maximum values at 25 °C ambient temperature and sea level)

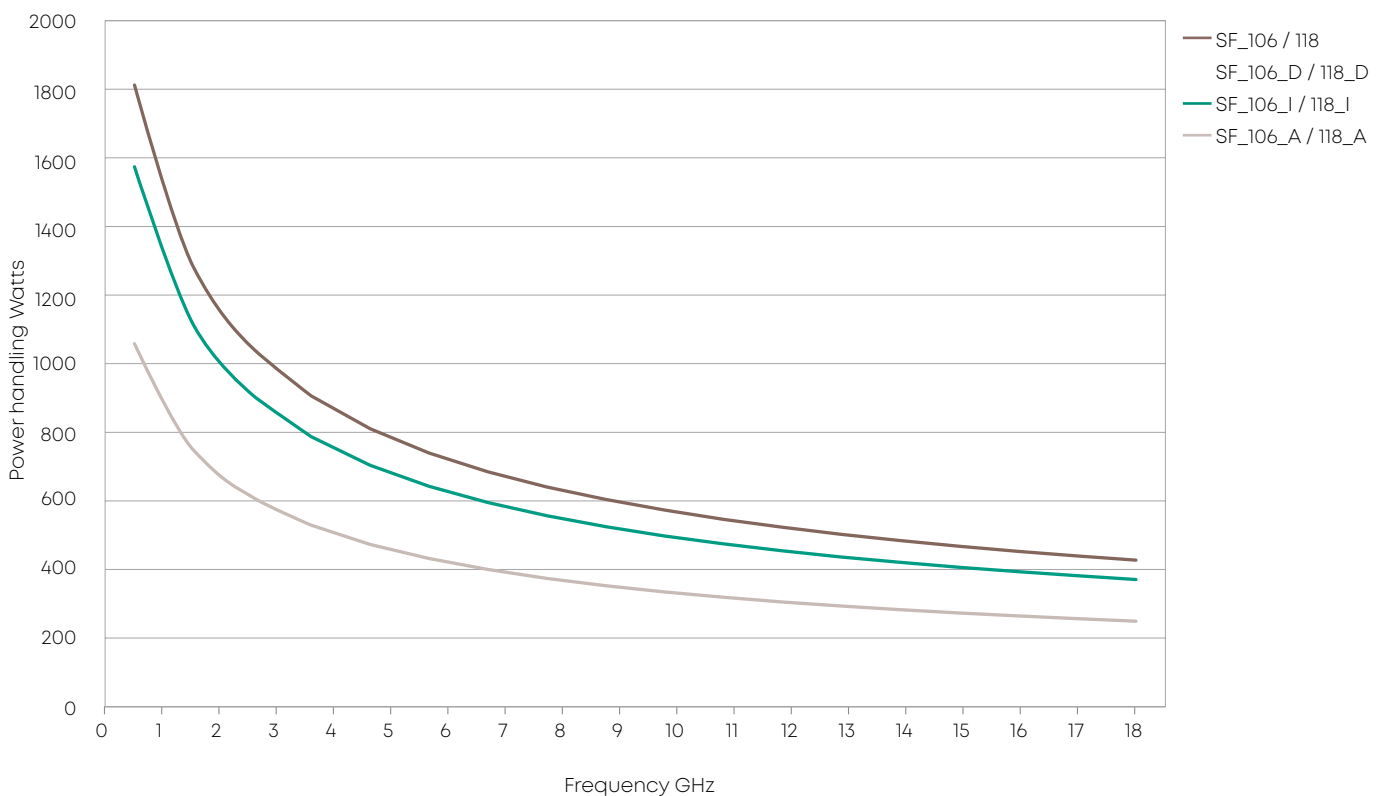

SUCOFLEX® 106 / 118

Available connectors

Con- nec- tor	Series, pattern	HUBER+ SUHNER connector type	SF106 SF106_D	SF_106_A	SF_106_I	SF 118 SF118_D	SF_118_A	SF_118_I	Operating frequency GHz	VSWR per con- nec- tor	Remarks
N	Straight cable plug	SF_11_N-651	•	•	•				18	1,12	
	Straight cable plug	SF_11_N-662	•	•	•				18	1,12	High salt resistant (SS316L), hex-agonal nut with safety holes
	Straight cable plug	SF_11_N-653				•	•		18	1,12	High salt resistant (SS316L), hex-agonal nut with safety holes
	Straight cable plug	SF_11_N-656				•	•	•	18	1,12	
	Right angle cable plug	SF_16_N-651	•		•				11 18	1,12 1,22	
	Right angle cable plug	SF_16_N-653		•					11 18	1,12 1,22	
	Right angle cable plug	SF_16_N-654	•		•				11 18	1,12 1,22	High salt resistant (SS316L), hex-agonal nut with safety holes
	Right angle cable plug	SF_16_N-656				•	•	•	11 18	1,12 1,22	High salt resistant (SS316L), hex-agonal nut with safety holes
	Straight cable jack	SF_21_N-601				•	•	•	18	1,12	
	Straight panel bulkhead cable jack	SF_24_N-651	•	•	•				18	1,12	High salt resistant (SS316L), hex-agonal nut with safety holes, mounting hole size 12
	Straight panel bulkhead cable jack	SF_24_N-652				•	•		18	1,12	High salt resistant (SS316L), hex-agonal nut with safety holes, mounting hole size 12
SMA	Straight cable plug	SF_11_SMA-652	•	•	•				18	1,12	
	Straight cable plug	SF_11_SMA-655	•	•	•				18	1,12	High salt resistant (SS316L), hex-agonal nut with safety holes
	Straight cable plug	SF_11_SMA-653				•	•		18	1,12	High salt resistant (SS316L), hex-agonal nut with safety holes
	Straight cable plug	SF_11_SMA-656				•	•	•	18	1,12	
	Right angle cable plug	SF_16_SMA-652	•		•				18	1,22	
	Right angle cable plug	SF_16_SMA-653	•		•				18	1,22	High salt resistant (SS316L), hex-agonal nut with safety holes
	Right angle cable plug	SF_16_SMA-654				•	•		18	1,22	High salt resistant (SS316L), hex-agonal nut with safety holes
	Straight cable jack	SF_21_SMA-651	•	•					18	1,12	
	Straight cable jack	SF_21_SMA-652				•	•	•	18	1,12	
	Straight panel bulkhead cable jack	SF_24_SMA-651	•	•	•		•		18	1,12	mounting hole size 35
TNC	Straight cable plug	SF_11_TNC-651		•					18	1,16	
	Straight cable plug	SF_11_TNC-653	•		•				18	1,12	
	Straight cable plug	SF_11_TNC-658	•		•				18	1,12	High salt resistant (SS316L), hex-agonal nut with safety holes
	Straight cable plug	SF_11_TNC-654				•	•		18	1,16	High salt resistant (SS316L), hex-agonal nut with safety holes
	Right angle cable plug	SF_16_TNC-651	•		•				18	1,22	High salt resistant (SS316L), hex-agonal nut with safety holes
	Right angle cable plug	SF_16_TNC-655				•	•		18	1,22	High salt resistant (SS316L), hex-agonal nut with safety holes
	Straight cable jack	SF_21_TNC-651	•		•				18	1,12	
	Straight cable jack	SF_21_TNC-653				•	•		18	1,12	High salt resistant (SS316L)
	Straight panel bulkhead cable jack	SF_24_TNC-653	•		•				18	1,12	High salt resistant (SS316L), hex-agonal nut with safety holes, mounting hole size 4
	Straight panel bulkhead cable jack	SF_24_TNC-655				•	•		18	1,12	High salt resistant (SS316L), hex-agonal nut with safety holes, mounting hole size 4
716	Straight cable plug	SF_11_716-61	•	•	•				7,5	1,12	
	Straight cable jack	SF_21_716-61	•	•	•				7,5	1,12	

Overview SUCOFLEX® 300

The light weight, high performance cable assembly

Product description

The SUCOFLEX 300 lightweight, low-loss flexible microwave cable assemblies are high-end products designed to meet the stringent needs of space flight systems (e. g. satellites).

The 300 series offers a consistently outstanding mechanical and electrical performance, stability and reliability up to 18 GHz. The added feature of this SUCOFLEX type is a weight reduction of up to 50 % compared to our conventional products.

Product features for space applications

- Assemblies produced in a clean environment room
- Specifically designed lightweight connectors
- Extensive testing of assemblies
- High-end assemblies approved by Europe's leading satellite manufacturers



Recommended connectors

SF_304_Space	SMA
SF_307_Space	TNC
	Other connectors available on request

Technical data

HUBER+SUHNER type	Operating frequency	Temperature range	Outer diameter	Nominal attenuation 18 GHz, 25°C	Bending radii		Weight g
	GHz	°C	mm	dB/m	static mm	repeated mm	
SUCOFLEX_304_Space	18	-55 to +150	5,4	1,2	20	50	46
SUCOFLEX_307_Space	8	-55 to +150	9,0	0,4 at 8 GHz	50	100	133

SUCOFLEX® 304_Space

The light weight, high performance microwave cable assembly working up to 18 GHz

Product description

The SUCOFLEX 304 light weight, high end cable assemblies are designed to provide optimal performance up to 18 GHz were light weight, stringent electrical requirements – in particular stability and lowest loss, are important.

Product features

- Impedance 50 Ω
- Applicable up to 18 GHz
- 45 % weight reduction compared to standard SUCOFLEX 104 assemblies (lower launching costs)
- Production in clean room
- All space connectors vented
- Outgassing according ECSS-Q-ST-70-02C and NASA reference publication 1124



Recommended connectors

SF_304_Space	SMA
	Other connectors available on request

Construction

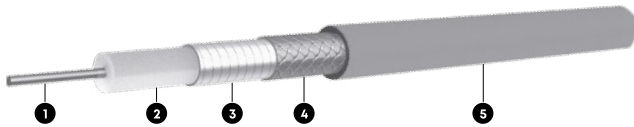

SF_304_Space

Cable	Inner conductor ①	Dielectric ②	Outer conductor ③ ④	Jacket ⑤	Outer diameter
					mm
SUCOFLEX_304_SPACE	AlCuAg wire	LD-PTFE	CuAg tape/AlCuAg braid	ETFE, blue	5.4

Other SUCOFLEX 304 cables available on request.

Available connectors

Connector	Series, pattern	HUBER+SUHNER connector type	Operating frequency	VSWR per connector	Remarks
SMA	straight cable plug	SF_11_SMA-487_Space	18	1,12	vented
	right angle cable plug	SF_16_SMA-489_Space	18	1,12	vented

SUCOFLEX® 304_Space

Assembly types

		SUCOFLEX 304_Space
Construction		
Max. operating frequency	GHz	18
Application		static
Velocity of propagation	%	77
Weight	g/m	46
Min. bending radius static	mm	20
Min. bending radius repeated	mm	50
Temperature range	°C	-55 to +150
Tensile load	N	250
Inner conductor		solid wire
Dielectric		LD-PTFE
Outer conductor		tape/braid
Jacket		ETFE
Ruggedisation		no
Outer diameter	mm	5.4
Screening effectiveness (up to 18 GHz)	dB	> 90
Phase stability vs. flexure (360°, diameter 55 mm)	°el/GHz	< 1.5
Phase stability vs. temperature (-40 to +85 °C)	ppm	< 1500
Assembly phase matching tolerances	°el/GHz	± 0.5
Cable attenuation at 25 °C	dB/m	see graph
Insertion loss stability vs. bending	dB	± 0.1
Insertion loss stability vs. temperature	%/°C	< 0.2
Insertion loss stability vs. shaking	dB	± 0.1
Power handling	watt	see graph
Radiation resistance	Mrad	100
Connectors vented		yes
Out gassing according ECSS-Q-ST-70-02 and NASA reference publication 1124		TML < 1 %, CVCM < 0.1 %
Soldering according to ESA qualified materials and processes		ECSS-Q-70-08A and ECSS-Q-70-18A
Assembling in clean room		general: class 10 000 working area: class 100

SUCOFLEX® 304_Space

Attenuation (nominal values at +25 °C ambient temperature)

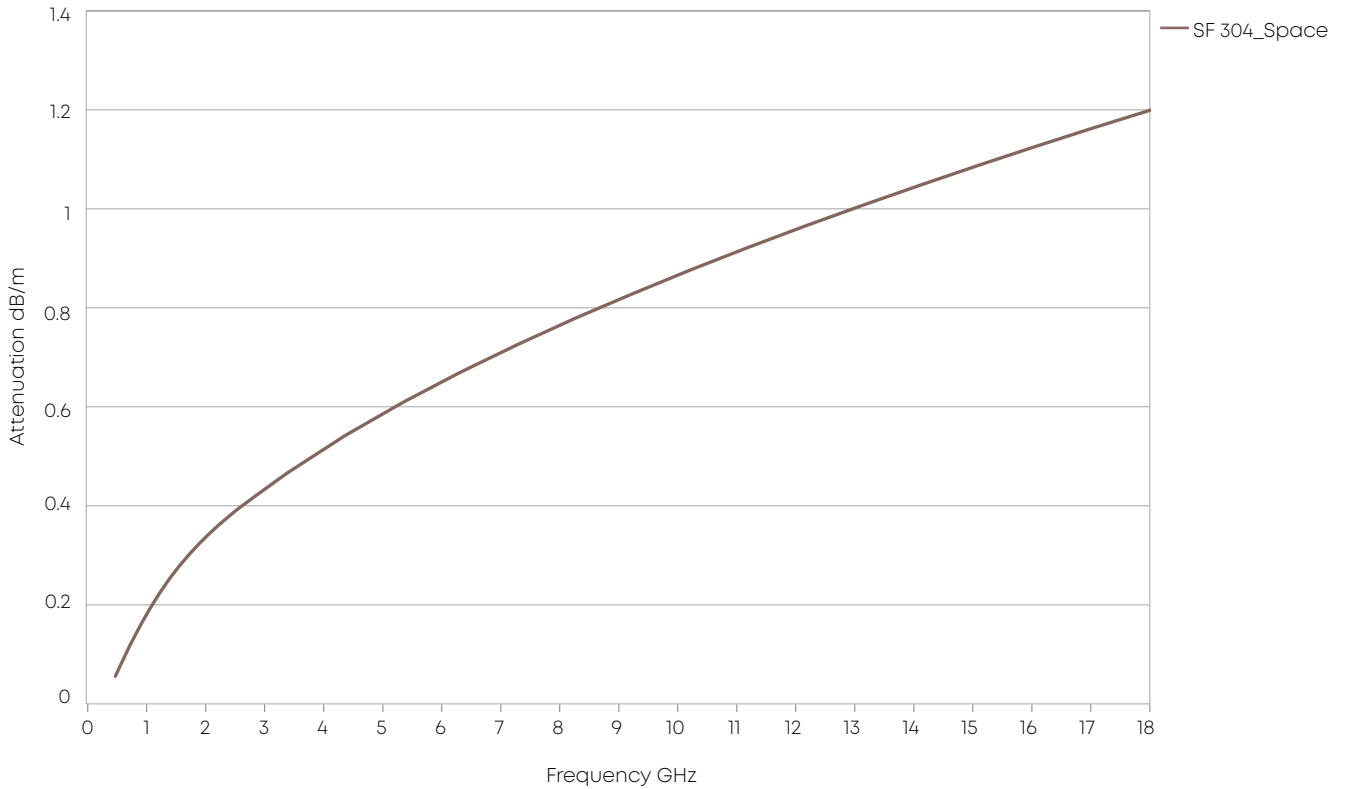

Power handling (maximum values at 25 °C ambient temperature and sea level)

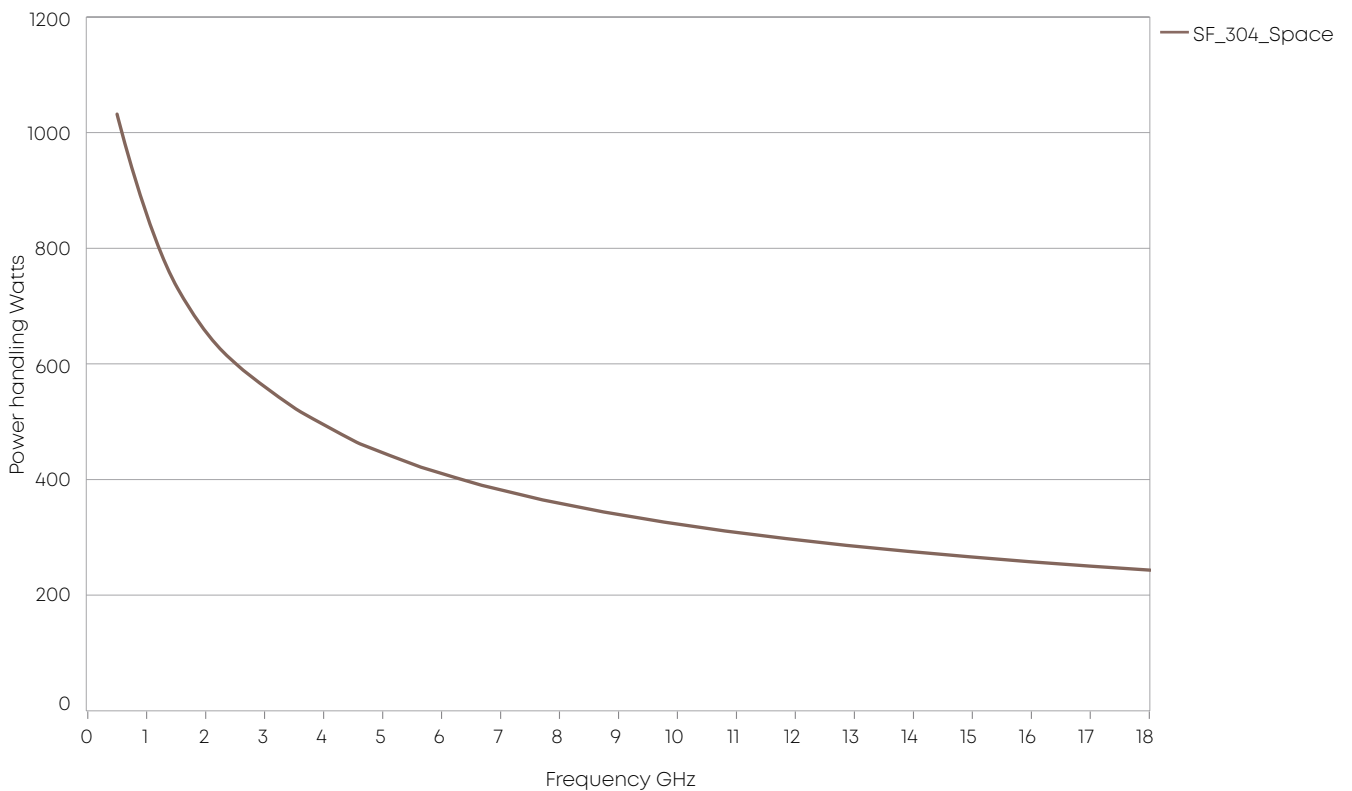

SUCOFLEX® 307_Space

The light weight, high performance microwave cable assembly working up to 8 GHz

Product description

The SUCOFLEX 307_Space light weight, high end cable assemblies are designed to provide optimal performance up to 8 GHz were light weight, high power, stringent electrical requirements – in particular stability and low loss, are important.

Product features

- Impedance 50 Ω
- Applicable up to 8 GHz
- High power application
- Centre conductor and braid in aluminum instead of copper
- Production in clean room
- Extensive testing of the assembly
- Customer specific qualification
- All connectors vented
- Outgassing according ECSS-Q-ST-70-02C and NASA reference publication 1124
- MIL-DTL-17 qualified
- Mechanical stability
- Low loss

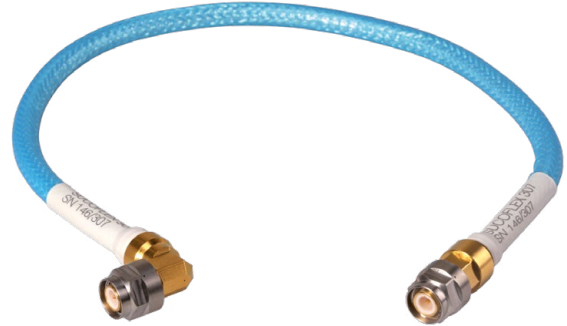

Recommended connectors

SF307_Space	TNC
	Other connectors available on request

Construction

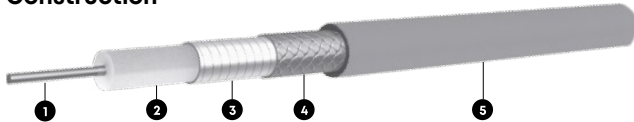

Cable	Inner conductor ①	Dielectric ②	Outer conductor ③ ④	Jacket ⑤	Outer diameter
					mm
SUCOFLEX_307_Space	AlCuAg wire	LD-PTFE	CuAg tape/AlCuAg braid	ETFE, blue	9.0

Available connectors

Connector	Series, pattern	HUBER+SUHNER connector type	SF307_Space	Operating frequency	VSWR per connector	Remarks
				GHz		
TNC	straight cable plug	11_TNC-721_Space	•	5.5	1.07	vented
	right angle cable plug	16_TNC-721_Space	•	5.5	1.07	vented

SUCOFLEX® 307_Space

Assembly types

		SUCOFLEX 307_Space
Construction		
Max. operating frequency	GHz	8
Application		static
Velocity of propagation	%	77
Weight	g/m	133
Min. bending radius static	mm	50
Min. bending radius repeated	mm	100
Temperature range	°C	-55 to +150
Tensile load	N	340
Inner conductor		solid wire
Dielectric		LD-PTFE
Outer conductor		tape/braid
Jacket		ETFE
Outer diameter	mm	9.0
Screening effectiveness (up to 18 GHz)	dB	> 90
Phase stability vs. flexure (360°, diameter 125 mm)	°el/GHz	< 2.0
Phase stability vs. temperature (-40 to +85 °C)	ppm	< 1500
Assembly phase matching tolerances	°el/GHz	± 0.5
Cable attenuation at 25 °C	dB/m	see graph
Insertion loss stability vs. bending	dB	± 0.1
Insertion loss stability vs. temperature	%/°C	< 0.45
Insertion loss stability vs. shaking	dB	± 0.1
Power handling	watt	see graph
Radiation resistance	Mrad	100
Connectors vented		yes
Out gassing according ECSS-Q-ST-70-02 and NASA reference publication 1124		TML < 1 %, CVCM < 0.1 %
Soldering according to ESA qualified materials and processes		ECSS-Q-70-08A and ECSS-Q-70-18A
Assembling in clean room		general: class 10 000 working area: class 100

SUCOFLEX® 307_Space

Attenuation (nominal values at +25 °C ambient temperature)

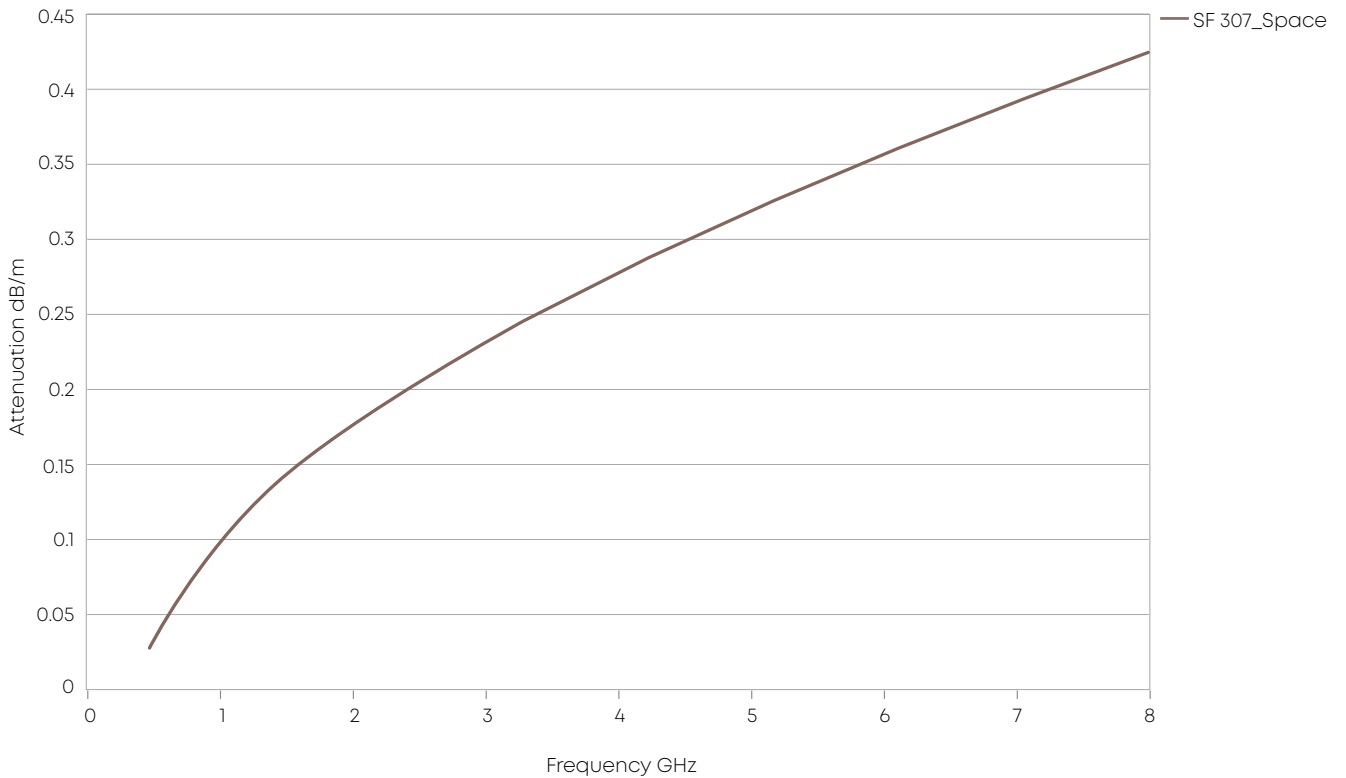

Power handling (maximum values at 25 °C ambient temperature and sea level)

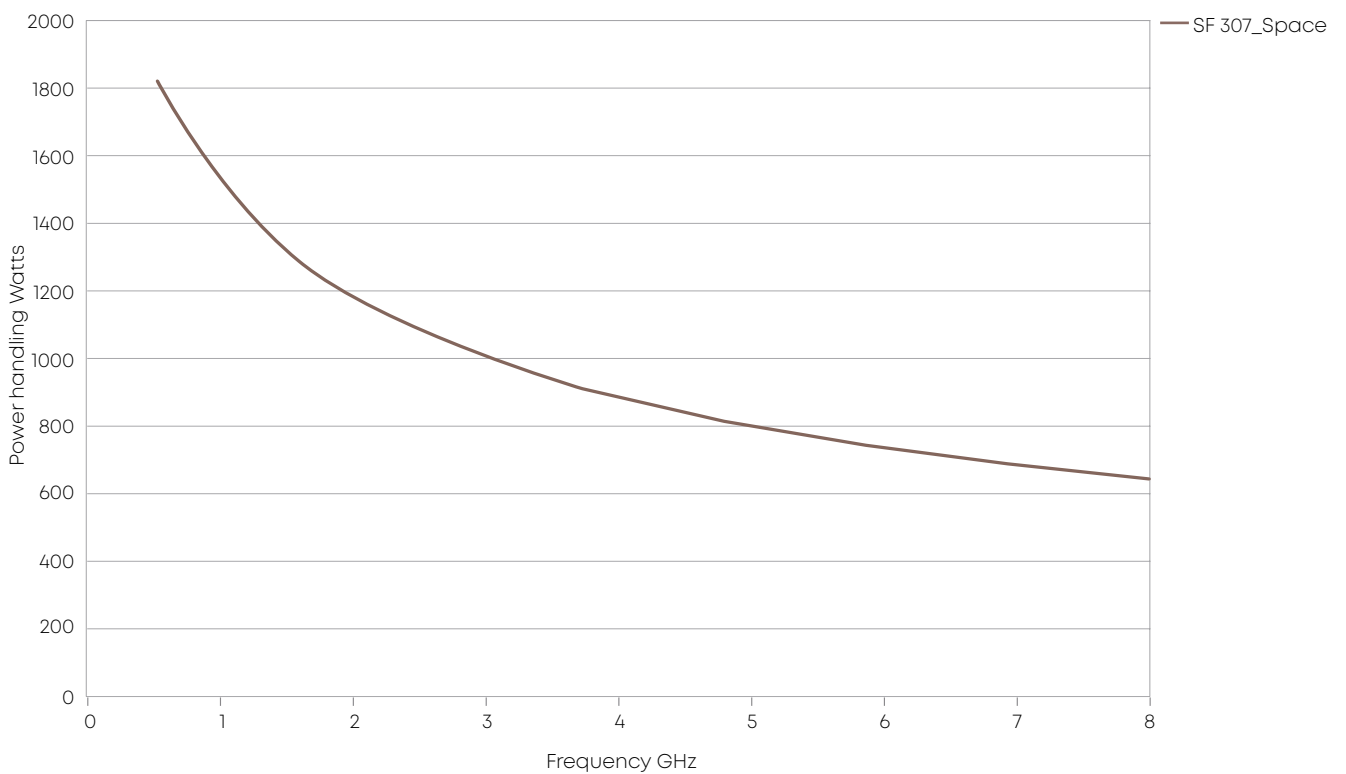

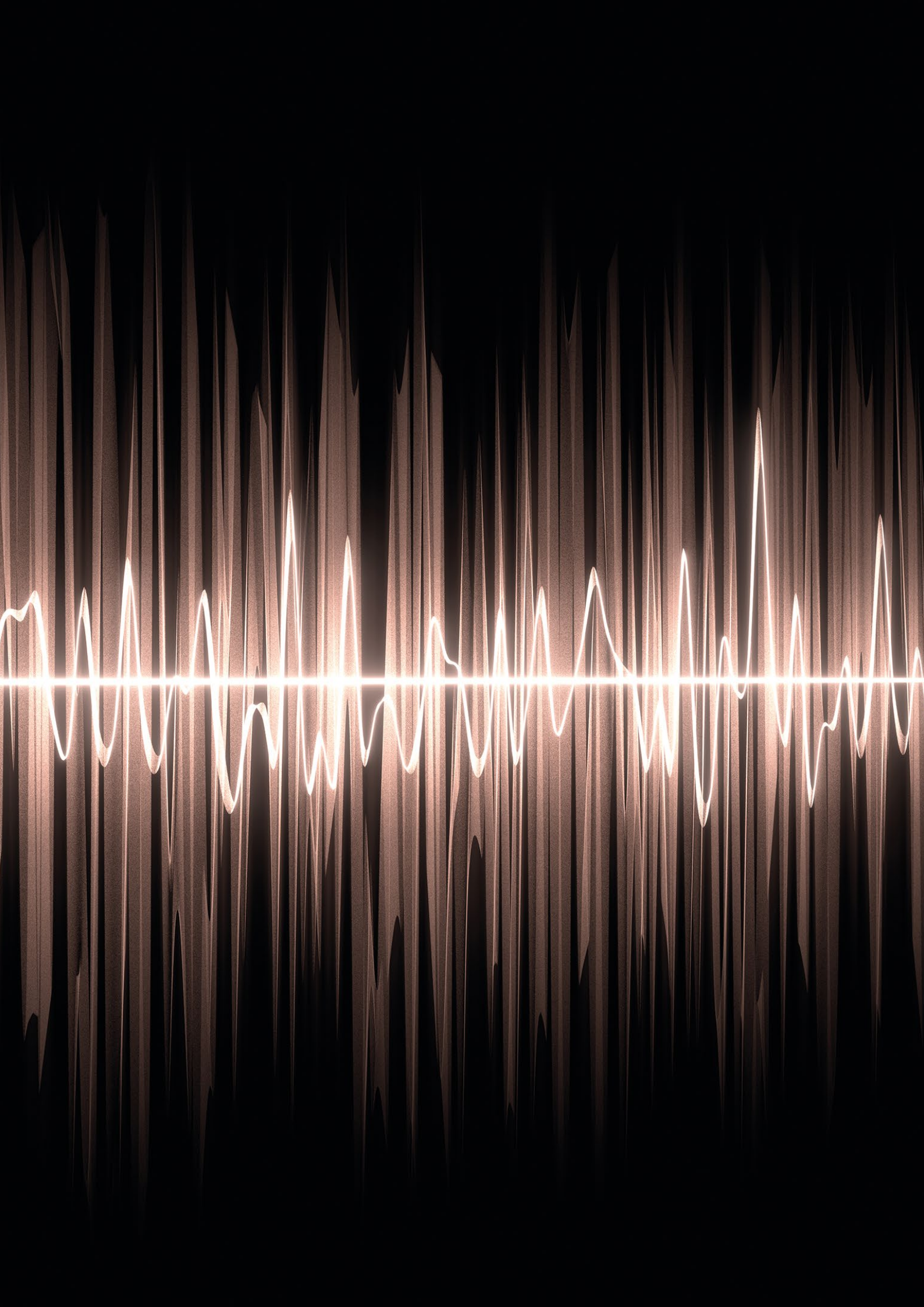

SUCOFLEX[®] 500

When it comes to test and measurement, the SUCOFLEX 500 assemblies guarantee the highest level of satisfaction. Thanks to their unique cable and connector design, they deliver the best phase and amplitude stability versus flexure, movement, temperature and tensile stress, in combination with outstanding return and insertion loss up to 70 GHz.

Due to the rotary swaged low-loss inner conductor and the rugged construction, SUCOFLEX 500 assemblies typically withstand more than 100,000 flexures without degradation of performance and therefore have a very long life-time.

HUBER+SUHNER supplies all SUCOFLEX 500 standard length products within five working days and customised lengths are available within ten working days worldwide.



Short delivery time



Outstanding performance



Excellent price-performance ratio

Sucoflex 526 E/EA/S
Sucoflex 540 E/EA/S
Sucoflex 550 E/EA/S
Sucoflex 570 E/S

- High electrical performance up to 70 GHz
- Excellent return and insertion loss
- Best-in-class phase and amplitude stability with flexure and movement
- Very long service life (>100.000 flex cycles)
- Variety of interface options available



Sucoflex 526V

- Consistent electrical performance up to 26.5 GHz
- Best-in-class phase and amplitude stability with flexure, movement, temperature, and tensile stress
- Extremely flexible and simplifies handling and routing

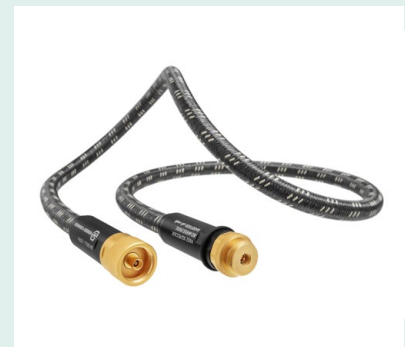

SUCOFLEX® 500 Variations



26.5 GHz	SUCOFLEX 526	SUCOFLEX 526E	SUCOFLEX 526EA	SUCOFLEX 526S	SUCOFLEX 526V
40 GHz	SUCOFLEX 540	SUCOFLEX 540E	SUCOFLEX 540EA	SUCOFLEX 540S	
50 GHz	SUCOFLEX 550	SUCOFLEX 550E	SUCOFLEX 550EA	SUCOFLEX 550S	
70 GHz	SUCOFLEX 570	SUCOFLEX 570E		SUCOFLEX 570S	

Applications

- Bench top testing
- RF production testing
- Automated test equipment
- Vector network analyzers (VNAs)
- Scalar analyzers
- Portable test equipment
- RF module testing
- High speed digital testing (HSDT)

SUCOFLEX® 526 – 26.5 GHz



Mechanical data

Frequency	26.5 GHz			
Cable	SUCOFLEX 526	SUCOFLEX 526E	SUCOFLEX 526EA	SUCOFLEX 526S
Connectors	PC3.5 (3.5 mm), SMA, N			
Diameter (mm)	5.5	5.5	10.3	7.7
Outer jacket material	FEP	PUR	PUR	PTFE
Crush resistant	No	No	Yes	Yes
Min. bending radius (mm)	16	16	30	25.4
Typ. flex life (cycles)	> 100'000			
Min. assembly length (mm)	300			
Max. assembly length (mm)	50,000	50,000	40,000	50,000

Environmental data

Operating temperature (°C)	-55 to +125°C	-40 to +85°C	-40 to +85°C	-55 to +125°C
2011/65/EC (RoHS)	compliant			
2006/1907/EC (REACH)	compliant			
2012/19/EU (WEEE)	relevant			

Electrical data

Impedance (Ω)	50			
Velocity of propagation (%)	77			
Typ. return loss (dB)	25			
Min. return loss (dB)	19 (up to 18 GHz) 16.6 (up to 26.5 GHz)			
Typ. insertion loss assembly (dB/m)	1.63			
Max. insertion loss assembly (dB/m)	1.77			
Min. screening effectiveness (dB) up to 18 GHz	90			
Typ. amplitude stability vs. movement (dB)	± 0.1	± 0.1	± 0.1	± 0.05
Typ. amplitude stability vs. flexure (dB)	± 0.1	± 0.1	± 0.1	± 0.05
Typ. phase stability vs. bending (°)	±8	±8	±8	± 3
Relative and absolute time delay matching: ±1 ps	available on request			

SUCOFLEX 526 stock assemblies

Art. No	Cable	Connector 1	Connector 2	Length (mm)	Length (inch)	Frequency (GHz)	max. IL (dB)	min. RL (dB)
85207923	SF526E/11PC35/11PC35/24in	3.5mm male	3.5mm male	610	24	26.5	1.18	16.6
85207924	SF526E/11PC35/11PC35/36in	3.5mm male	3.5mm male	914	36	26.5	1.64	16.6
85154814	SF526S/11PC35/11PC35/24in	3.5mm male	3.5mm male	610	24	26.5	1.18	16.6
85088164	SF526S/11PC35/11PC35/36in	3.5mm male	3.5mm male	914	36	26.5	1.64	16.6
85092086	SF526S/11PC35/11PC35/48in	3.5mm male	3.5mm male	1219	48	26.5	2.10	16.6

Absolute time delay matched stock assemblies

Art. No	Part no.	Connector 1	Connector 2	Length (mm)	Length (inch)	Frequency (GHz)	max. IL (dB)	Min. RL (dB)	Absolute time delay matching
85207925	PMA SF526E/11PC35/11PC35/24in	3.5mm male	3.5mm male	610	24	26.5	1.18	16.6	± 1ps
85207926	PMA SF526E/11PC35/11PC35/36in	3.5mm male	3.5mm male	914	36	26.5	1.64	16.6	± 1ps
85185119	PMA SF526S/11PC35/11PC35/24in	3.5mm male	3.5mm male	610	24	26.5	1.18	16.6	± 1ps
85185120	PMA SF526S/11PC35/11PC35/36in	3.5mm male	3.5mm male	914	36	26.5	1.64	16.6	± 1ps

SUCOFLEX® 540 – 40 GHz



SUCOFLEX 540S



SUCOFLEX 540



SUCOFLEX 540E



SUCOFLEX 540EA

Mechanical data

Frequency	40 GHz			
Cable	SUCOFLEX 540	SUCOFLEX 540E	SUCOFLEX 540EA	SUCOFLEX 540S
Connector	PC2.4, SK (2.4 mm, 2.92 mm)			
Diameter (mm)	4.0	4.0	7.7	6.4
Outer jacket material	FEP	PUR	PUR	PTFE
Crush resistant	No	No	Yes	Yes
Min. bending radius (mm)	12	12	20	25.4
Typ. flex life (cycles)	> 100 000			
Min. assembly length (mm)	300			
Max. assembly length (mm)	20 000	20 000	20 000	20 000

Environmental data

Operating temperature (°C)	-55 to +125	-40 to +85	-40 to +85	-55 to +125
2011/65/EC (RoHS)	compliant			
2006/1907/EC (REACH)	compliant			
2012/19/EU (WEEE)	relevant			

Electrical data

Impedance (Ω)	50			
Velocity of propagation (%)	77			
Typ. return loss (dB)	17			
Min. return loss (dB)	14.9			
Typ. insertion loss assembly (dB/m)	2.95			
Max. insertion loss assembly (dB/m)	3.21			
Min. screening effectiveness (dB) up to 18 GHz	90			
Typ. amplitude stability vs. movement (dB)	± 0.1	± 0.1	± 0.1	± 0.05
Typ. amplitude stability vs. flexure (dB)	± 0.1	± 0.1	± 0.1	± 0.05
Typ. phase stability vs. flexure (°)	± 8.0	± 8.0	± 8.0	± 5.0
Relative and absolute time delay matching: ±1 ps	available on request			

SUCOFLEX 540 stock assemblies

Art. No	Cable	Connector 1	Connector 2	Length (mm)	Length (inch)	Frequency (GHz)	max. IL (dB)	min. RL (dB)
85207914	SF540E/11SK/11SK/24in	2.92mm male	2.92mm male	610	24	40	2.08	14.9
85207915	SF540E/11SK/11SK/36in	2.92mm male	2.92mm male	914	36	40	2.96	14.9
85207918	SF540S/11SK/11SK/24in	2.92mm male	2.92mm male	610	24	40	2.08	14.9
85207919	SF540S/11SK/11SK/36in	2.92mm male	2.92mm male	914	36	40	2.96	14.9

Absolute time delay matched stock assemblies

Art. No	Part no.	Connector 1	Connector 2	Length (mm)	Length (inch)	Frequency (GHz)	max. IL (dB)	Min. RL (dB)	Absolute time delay matching
85207916	PMA SF540E/11SK/11SK/24in	2.92mm male	2.92mm male	610	24	40	2.08	14.9	± 1ps
85207917	PMA SF540E/11SK/11SK/36in	2.92mm male	2.92mm male	914	36	40	2.96	14.9	± 1ps
85207921	PMA SF540S/11SK/11SK/24in	2.92mm male	2.92mm male	610	24	40	2.08	14.9	± 1ps
85207922	PMA SF540S/11SK/11SK/36in	2.92mm male	2.92mm male	914	36	40	2.96	14.9	± 1ps

SUCOFLEX® 550 – 50 GHz



SUCOFLEX 550S



SUCOFLEX 550



SUCOFLEX 550E



SUCOFLEX 550EA

Mechanical data

Frequency	50 GHz			
Cable	SUCOFLEX 550	SUCOFLEX 550E	SUCOFLEX 550EA	SUCOFLEX 550S
Connector	PC2.4, SK (2.4 mm, 2,92 mm)			
Diameter (mm)	3.7	3.7	7.7	6.1
Outer jacket material	FEP	PUR	PUR	PTFE
Crush resistant	no	no	yes	yes
Min. bending radius (mm)	11	11	20	25.4
Typ. flex life (cycles)	> 100 000			
Min. assembly length (mm)	300			
Max. assembly length (mm)	20 000	20 000	20 000	20 000

Environmental data

Operating temperature (°C)	-55 to +125	-40 to +85	-40 to +85	-55 to +125
2011/65/EC (RoHS)	compliant			
2006/1907/EC (REACH)	compliant			
2012/19/EU (WEEE)	relevant			

Electrical data

Impedance (Ω)	50			
Velocity of propagation (%)	77			
Typ. return loss (dB)	17			
Min. return loss (dB)	14.9			
Typ. insertion loss assembly (dB/m)	3.87			
Max. insertion loss assembly (dB/m)	4.22			
Min. screening effectiveness (dB) up to 18 GHz	90			
Typ. amplitude stability vs. movement (dB)	± 0.1	± 0.1	± 0.1	± 0.05
Typ. amplitude stability vs. flexure (dB)	± 0.1	± 0.1	± 0.1	± 0.05
Typ. phase stability vs. flexure (°)	± 10	± 10	± 10	± 6.0
Relative and absolute time delay matching: ±1 ps	available on request			

SUCOFLEX® 550 – 50 GHz

SUCOFLEX 550 stock assemblies

Art. No	Cable	Connector 1	Connector 2	Length (mm)	Length (inch)	Frequency (GHz)	max. IL (dB)	min. RL (dB)
85185826	SF550E/11PC24/11PC24/24in	2.4 mm male	2.4 mm male	610	24	50	2.89	14.9
85157329	SF550E/11PC24/11PC24/36in	2.4 mm male	2.4 mm male	914	36	50	4.07	14.9
85120065	SF550S/11PC24/11PC24/24inch	2.4 mm male	2.4 mm male	610	24	50	2.89	14.9
85120066	SF550S/11PC24/11PC24/36inch	2.4 mm male	2.4 mm male	914	36	50	4.07	14.9
85120068	SF550S/11PC24/11PC24/48inch	2.4 mm male	2.4 mm male	1219	48	50	5.24	14.9

Absolute time delay matched SUCOFLEX 550 stock assemblies

Art. No	Part no.	Connector 1	Connector 2	Length (mm)	Length (inch)	Frequency (GHz)	max. IL (dB)	Min. RL (dB)	Absolute time delay matching
85169945	PMA SF550E/11PC24/11PC24/24in	2.4 mm male	2.4 mm male	610	24	50	2.89	14.9	± 1ps
85169947	PMA SF550E/11PC24/11PC24/36in	2.4 mm male	2.4 mm male	914	36	50	4.07	14.9	± 1ps
85153038	PMA SF550S/11PC24/11PC24/24in	2.4 mm male	2.4 mm male	610	24	50	2.89	14.9	± 1ps
85153039	PMA SF550S/11PC24/11PC24/36in	2.4 mm male	2.4 mm male	914	36	50	4.07	14.9	± 1ps
85185117	PMA SF550S/11SK/11SK/24in	2.92 mm male	2.92 mm male	610	24	40	2.58	14.9	± 1ps
85185118	PMA SF550S/11SK/11SK/36in	2.92 mm male	2.92 mm male	914	36	40	3.61	14.9	± 1ps

SUCOFLEX® 570 – 70 GHz



SUCOFLEX 570S



SUCOFLEX 570



SUCOFLEX 570E

Mechanical data

Frequency	70 GHz		
Cable	SUCOFLEX 570	SUCOFLEX 570E	SUCOFLEX 570S
Connector	1.85 mm		
Diameter (mm)	3.3	3.3	5.8
Outer jacket material	FEP	PUR	PTFE
Crush resistant	no	no	yes
Min. bending Radius (mm)	11	11	25.4
Typ. Flex life (cycles)	> 20'000		
Min. assembly length (mm)	300	300	300
Max. assembly length (mm)	10'000	10'000	10'000

Environmental data

Operating temperature (°C)	-55 to +125	-40 to +85	-55 to +125
2011/65/EC (RoHS)	compliant		
2006/1907/EC (REACH)	compliant		
2012/19/EU (WEEE)	relevant		

Electrical data

Impedance (Ω)	50		
Velocity of propagation (%)	77		
Typ. return loss (dB)	16		
Min. return loss (dB)	14		
Typ. insertion loss assembly (dB/m)	6.48		
Max. insertion loss assembly (dB/m)	7.05		
Min. screening effectiveness (dB) up to 18 GHz	90		
Typ. amplitude stability vs. movement (dB)	± 0.10	± 0.10	± 0.05
Typ. amplitude stability vs. flexure (dB)	± 0.10	± 0.10	± 0.05
Typ. phase stability vs. flexure (°)	± 10	± 10	± 8
Relative and absolute time delay matching (±1ps)	available on request		

SUCOFLEX® 570 – 70 GHz

SUCOFLEX 570 stock assemblies

Art. No	Cable	Connector 1	Connector 2	Length (mm)	Length (inch)	Frequency (GHz)	max. IL (dB)	min. RL (dB) @ 67 GHz
85184843	SF570E/11PC185/11PC185/24in	1.85 mm male	1.85 mm male	610	24	70	4.65	14.0
85184844	SF570E/11PC185/11PC185/36in	1.85 mm male	1.85 mm male	914	36	70	6.48	14.0
85186159	SF570S/11PC185/11PC185/24in	1.85 mm male	1.85 mm male	610	24	70	4.65	14.0
85149825	SF570S/11PC185/11PC185/36in	1.85 mm male	1.85 mm male	914	36	70	6.48	14.0
85186160	SF570S/11PC185/11PC185/48in	1.85 mm male	1.85 mm male	1219	48	70	8.50	14.0

Absolute time delay matched SUCOFLEX 570 stock assemblies

Art. No	Part no.	Connector 1	Connector 2	Length (mm)	Length (inch)	Frequency (GHz)	max. IL (dB)	Min. RL (dB) @ 67 GHz	Absolute time delay matching
85184845	PMA SF570E/11PC185/11PC185/24in	1.85 mm male	1.85 mm male	610	24	70	4.65	14.0	± 1ps
85184846	PMA SF570E/11PC185/11PC185/36in	1.85 mm male	1.85 mm male	914	36	70	6.48	14.0	± 1ps
85153051	PMA SF570S/11PC185/11PC185/24in	1.85 mm male	1.85 mm male	610	24	70	4.65	14.0	± 1ps
85153052	PMA SF570S/11PC185/11PC185/36in	1.85 mm male	1.85 mm male	914	36	70	6.48	14.0	± 1ps

SUCOFLEX® 500

Available connectors

	Freq. (GHz)	SUCOFLEX 526	SUCOFLEX 526E	SUCOFLEX 526EA	SUCOFLEX 526S	SUCOFLEX 526V
N straight male	18	SF_11_N-503	SF_11_N-504	SF_11_N-505	SF_11_N-501	
N straight female	18	SF_21_N-502	SF_21_N-503	SF_21_N-504	SF_21_N-501	
SMA straight male	18	SF_11_SMA-502	SF_11_SMA-503	SF_11_SMA-504	SF_11_SMA-501	
SMA straight female	18	SF_21_SMA-501	SF_21_SMA-502	SF_21_SMA-503		
3.5mm straight male	26.5	SF_11_PC35-509	SF_11_PC35-510	SF_11_PC35-511	SF_11_PC35-501	
3.5mm straight female	26.5	SF_21_PC35-506	SF_21_PC35-507	SF_21_PC35-508	SF_21_PC35-501	
3.5mm ruggedised PORT female	26.5				SF_21_PC35-502	
3.5mm ruggedised PORT female	26.5					35VF
3.5mm ruggedised DUT male	26.5					35VM
3.5mm DUT female	26.5					35F

	Freq. (GHz)	SUCOFLEX 540	SUCOFLEX 540EA	SUCOFLEX 540E	SUCOFLEX 540S
2.92mm male	40	SF_11_SK-505	SF_11_SK-507	SF_11_SK-506	SF_11_SK-508
2.92mm female	40	SF_21_SK-506	SF_21_SK-508	SF_21_SK-507	SF_21_SK-509
2.92mm ruggedised PORT female	40				
2.4mm male	50	SF_11_PC24-505	SF_11_PC24-507	SF_11_PC24-506	SF_11_PC24-508
2.4mm female	50	SF_21_PC24-506	SF_21_PC24-508	SF_21_PC24-507	SF_21_PC24-509

	Freq. (GHz)	SUCOFLEX 550	SUCOFLEX 550E	SUCOFLEX 550EA	SUCOFLEX 550S
3.5mm straight male	26.5	SF_11_PC35-505	SF_11_PC35-506	SF_11_PC35-507	SF_11_PC35-508
2.92mm male	40	SF_11_SK-502	SF_11_SK-503	SF_11_SK-504	SF_11_SK-501
2.92mm female	40	SF_21_SK-502	SF_21_SK-503	SF_21_SK-504	SF_21_SK-501
2.92mm ruggedised PORT female	40				SF_21_SK-505
2.4mm male	50	SF_11_PC24-502	SF_11_PC24-503	SF_11_PC24-504	SF_11_PC24-501
2.4mm female	50	SF_21_PC24-502	SF_21_PC24-503	SF_21_PC24-504	SF_21_PC24-501
2.4mm ruggedised PORT female	50				SF_21_PC24-505

	Freq. (GHz)	SUCOFLEX 570	SUCOFLEX 570E	SUCOFLEX 570S
1.85mm male	70	SF_11_PC185-502	SF_11_PC185-503	SF_11_PC185-501
1.85mm female	70	SF_21_PC185-503	SF_21_PC185-504	SF_21_PC185-501
1.85mm ruggedised PORT female	70			SF_21_PC185-502

Order Information

Connector 1
N, SMA, 3.5 mm, 2.92 mm, 2.4 mm, 1.85 mm

Connector 2

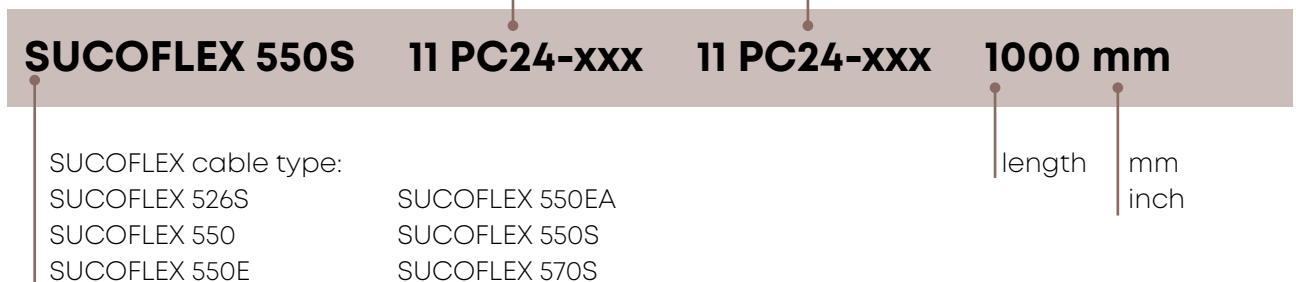

SUCOFLEX® 526V – 26.5 GHz

SUCOFLEX 526V

The only VNA microwave cable assembly worldwide with a typical 50 ppm phase variation vs. temperature between +15 and +30 °C. No “PTFE phase knee” at +19 °C as seen on conventional VNA test cable assemblies which cause phase variations and unstable measurements in critical laboratory conditions.



Available assemblies

Product configuration

Art. No.	85069744	85081169	85070046	85081172	85070047	85081177
Cable type	SUCOFLEX 526V					
Length	25" (635 mm)	25" (635 mm)	38" (965 mm)	38" (965 mm)	48" (1219 mm)	48" (1219 mm)
Connector 1	3.5 mm ruggedised PORT female (35VF)					
Connector 2	3.5 mm ruggedised DUT male (35VM)	3.5 mm DUT female (35F)	3.5 mm ruggedised DUT male (35VM)	3.5 mm DUT female (35F)	3.5 mm ruggedised DUT male (35VM)	3.5 mm DUT female (35F)

Mechanical data

Diameter (mm)	13
Min. bending radius (mm)	50
Crush resistance (kN/m)	80
Typ. flex life (cycles)	>100 000 2.0 Mio. for slight movements

Environmental data

Operating temperature	laboratory conditions, analyser specific (+15 to +30 °C)
2011/65/EC (RoHS)	compliant

Electrical data

Art. No.	85069744	85081169	85070046	85081172	85070047	85081177
Impedance (Ω)	50					
Operating frequency (GHz)	up to 26.5					
Velocity of propagation (%)	80					
Time delay (ns/m)	4.15					
Return loss (dB)	typ. 25 min. 20					
Insertion loss (dB)	max. 2.5		max. 3.6		max. 4.4	
Min. screening effectiveness (dB)	> 90					
Amplitude stability vs. movement (dB)	max. 0.05					
Amplitude stability vs. flexure (dB)	max. 0.08					
Phase stability vs. flexure (°)	max. 3.9		max. 7.4		max. 10	
Phase stability vs. tensile stress (°/GHz)	max. 0.1°/GHz (100 N)					
Phase stability vs. temperature (ppm)	typ. 50 (+15 to +30 °C)					

Order information stock assemblies

Art. No.	Description
85069744	SF526V/35VF/35VM/25in
85081169	SF526V/35VF/35F/25in
85070046	SF526V/35VF/35VM/38in
85081172	SF526V/35VF/35F/38in
85070047	SF526V/35VF/35VM/48in
85081177	SF526V/35VF/35F/48in

SUCOFLEX® 526V – 26.5 GHz

Phase shift vs. temperature (+15 °C to +30 °C)

		SUCOFLEX 526V	Conventional VNA test lead
Assembly length (in (mm))	Frequency (GHz)*	Phase shift /° (for 50 ppm, 80 % VOP)	Phase shift /° (for 700 ppm, 84 % VOP)
25 (635)	18	0.9	11.4
25 (635)	26.5	1.3	16.7

*Other frequencies on request

Phase stability vs. temperature performance

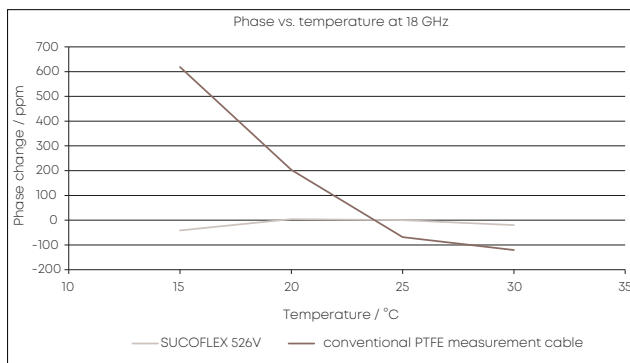

Phase stability vs. flexure

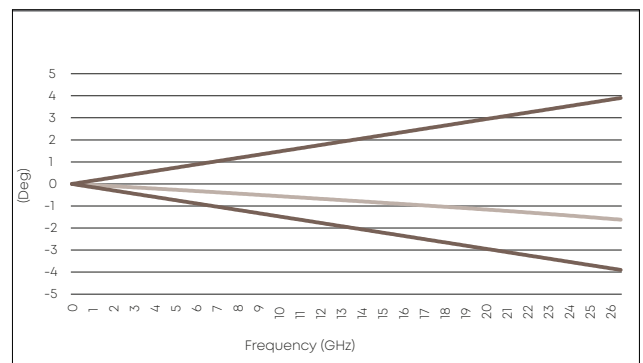

Insertion loss

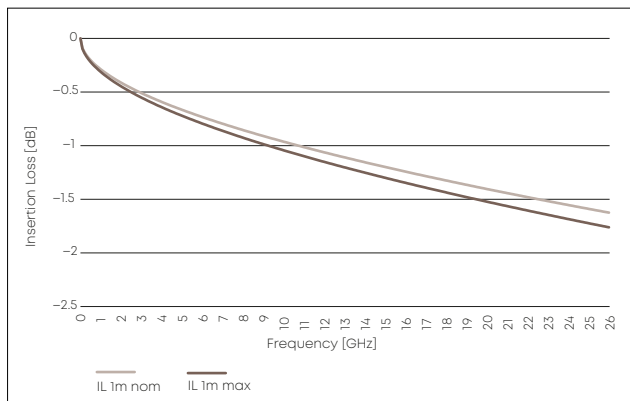

Loss stability vs. flexure

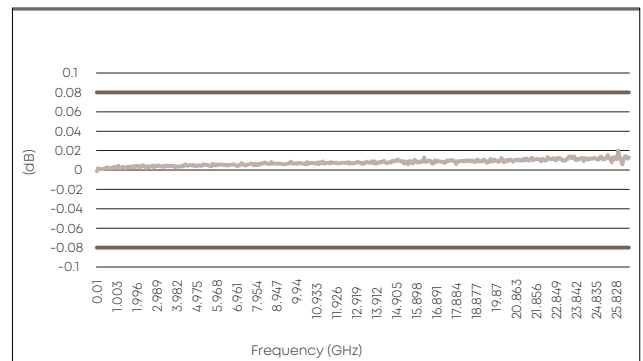

Return loss SUCOFLEX 526V with PC3.5 connectors

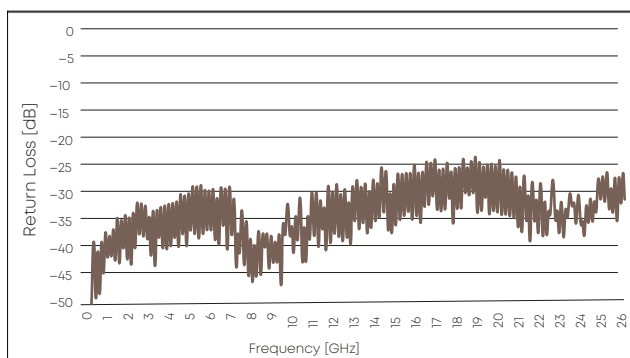

SUCOFLEX® 500

Connector configuration

Figure	Marketing name	Cable	B	D	SW / AF.
8	35F	SUCOFLEX_526_V	69.5	19.8	20
5	35VF	SUCOFLEX_526_V	69.5	19.8	20
7	35VM	SUCOFLEX_526_V	69.5	19.8	N/A
9	SF_11_N-501	SUCOFLEX_526_S	75.5	15.6	N/A
9	SF_11_N-503	SUCOFLEX_526	91.5	14.5	N/A
9	SF_11_N-504	SUCOFLEX_526_E	91.5	14.5	N/A
9	SF_11_N-505	SUCOFLEX_526_EA	82	15.6	N/A
2	SF_11_PC185-501	SUCOFLEX_570_S	43	9.2	N/A
2	SF_11_PC185-502	SUCOFLEX_570	64	9.5	N/A
2	SF_11_PC185-503	SUCOFLEX_570_E	64	9.5	N/A
2	SF_11_PC24-501	SUCOFLEX_550_S	43	9.2	N/A
2	SF_11_PC24-502	SUCOFLEX_550	64	9.5	N/A
2	SF_11_PC24-503	SUCOFLEX_550_E	64	9.5	N/A
2	SF_11_PC24-504	SUCOFLEX_550_EA	42	9.2	N/A
2	SF_11_PC24-505	SUCOFLEX_540	64	9.5	N/A
2	SF_11_PC24-506	SUCOFLEX_540_E	64	9.5	N/A
2	SF_11_PC24-507	SUCOFLEX_540_EA	42	11.8	N/A
2	SF_11_PC24-508	SUCOFLEX_540_S	43	9.2	N/A
1	SF_11_PC35-501	SUCOFLEX_526_S	44	11.8	N/A
1	SF_11_PC35-505	SUCOFLEX_550	65.5	9.5	N/A
1	SF_11_PC35-506	SUCOFLEX_550_E	65.5	9.5	N/A
1	SF_11_PC35-507	SUCOFLEX_550_EA	43.5	9.2	N/A
1	SF_11_PC35-508	SUCOFLEX_550_S	44.5	9.2	N/A
1	SF_11_PC35-509	SUCOFLEX_526	65.8	9.5	N/A
1	SF_11_PC35-510	SUCOFLEX_526_E	65.8	9.5	N/A
1	SF_11_PC35-511	SUCOFLEX_526_EA	50.5	15.6	N/A
1	SF_11_SK-501	SUCOFLEX_550_S	44.5	9.2	N/A
1	SF_11_SK-502	SUCOFLEX_550	65.5	9.5	N/A
1	SF_11_SK-503	SUCOFLEX_550_E	65.5	9.5	N/A
1	SF_11_SK-504	SUCOFLEX_550_EA	43.5	9.2	N/A
1	SF_11_SK-505	SUCOFLEX_540	65.5	9.5	N/A
1	SF_11_SK-506	SUCOFLEX_540_E	65.5	9.5	N/A
1	SF_11_SK-507	SUCOFLEX_540_EA	43.5	11.8	N/A
1	SF_11_SK-508	SUCOFLEX_540_S	44.5	9.2	N/A
1	SF_11_SMA-501	SUCOFLEX_526_S	44	11.8	N/A
1	SF_11_SMA-502	SUCOFLEX_526	65.8	9.5	N/A
1	SF_11_SMA-503	SUCOFLEX_526_E	65.8	9.5	N/A
1	SF_11_SMA-504	SUCOFLEX_526_EA	50.5	15.6	N/A
10	SF_21_N-501	SUCOFLEX_526_S	62	15.6	14
10	SF_21_N-502	SUCOFLEX_526	78.5	10	14
10	SF_21_N-503	SUCOFLEX_526_E	78.5	10	14
10	SF_21_N-504	SUCOFLEX_526_EA	68.5	15.6	14

SUCOFLEX® 500

Connector configuration

Figure	Marketing name	Cable	B	D	SW / AF.
4	SF_21_PC185-501	SUCOFLEX_570_S	43	9.2	8
4	SF_21_PC185-502	SUCOFLEX_570_S	60	19.8	20
4	SF_21_PC185-503	SUCOFLEX_570	64	9.5	8
4	SF_21_PC185-504	SUCOFLEX_570_E	64	9.5	8
4	SF_21_PC24-501	SUCOFLEX_550_S	43	9.2	8
4	SF_21_PC24-502	SUCOFLEX_550	64	9.5	8
4	SF_21_PC24-503	SUCOFLEX_550_E	64	9.5	8
4	SF_21_PC24-504	SUCOFLEX_550_EA	42	9.2	8
6	SF_21_PC24-505	SUCOFLEX_550_S	60	19.8	20
4	SF_21_PC24-506	SUCOFLEX_540	64	9.5	8
4	SF_21_PC24-507	SUCOFLEX_540_E	64	9.5	8
4	SF_21_PC24-508	SUCOFLEX_540_EA	42	11.8	8
4	SF_21_PC24-509	SUCOFLEX_540_S	43	9.2	8
3	SF_21_PC35-501	SUCOFLEX_526_S	44	11.8	8
5	SF_21_PC35-502	SUCOFLEX_526_S	61	19.8	20
3	SF_21_PC35-506	SUCOFLEX_526	65.8	9.5	8
3	SF_21_PC35-507	SUCOFLEX_526_E	65.8	9.5	8
3	SF_21_PC35-508	SUCOFLEX_526_EA	50.5	15.6	8
3	SF_21_SK-501	SUCOFLEX_550_S	44.5	9.2	8
3	SF_21_SK-502	SUCOFLEX_550	65.5	9.5	8
3	SF_21_SK-503	SUCOFLEX_550_E	65.5	9.5	8
3	SF_21_SK-504	SUCOFLEX_550_EA	43.5	9.2	8
6	SF_21_SK-505	SUCOFLEX_550_S	61	19.8	20
3	SF_21_SK-506	SUCOFLEX_540	65.5	9.5	8
3	SF_21_SK-507	SUCOFLEX_540_E	65.5	9.5	8
3	SF_21_SK-508	SUCOFLEX_540_EA	43.5	11.8	8
3	SF_21_SK-509	SUCOFLEX_540_S	44.5	9.2	8
3	SF_21_SMA-502	SUCOFLEX_526	65.8	9.5	8
3	SF_21_SMA-502	SUCOFLEX_526_E	65.8	9.5	8
3	SF_21_SMA-503	SUCOFLEX_526_EA	50.5	15.6	14

SUCOFLEX® 500

Figure 1

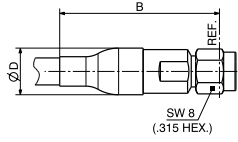

Figure 2

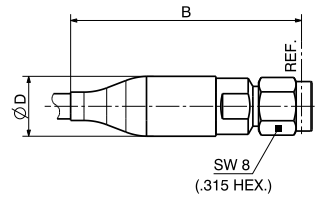

Figure 3

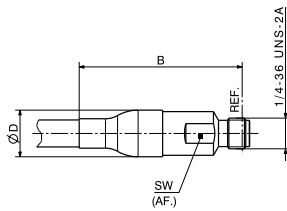

Figure 4

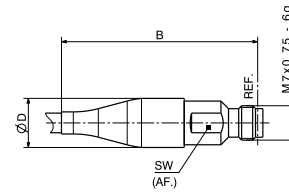

Figure 5

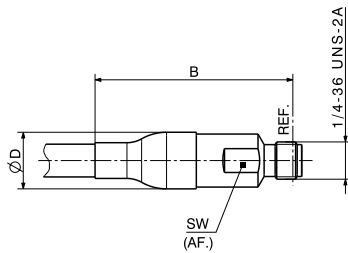

Figure 6

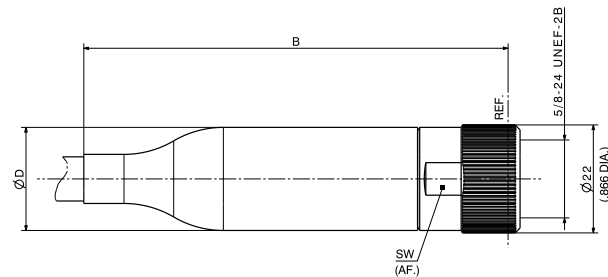

Figure 7

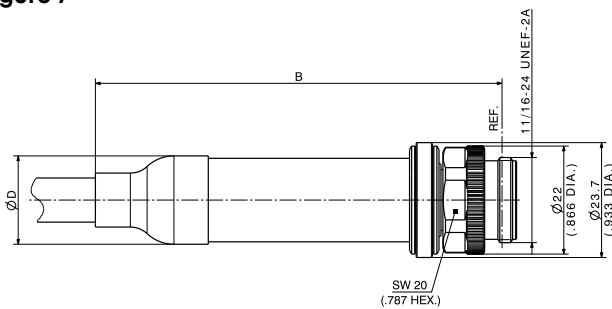

Figure 8

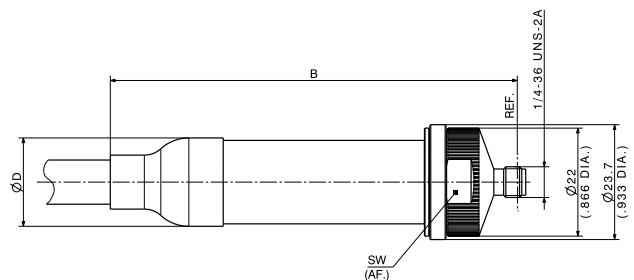

Figure 9

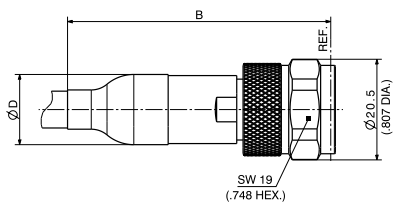
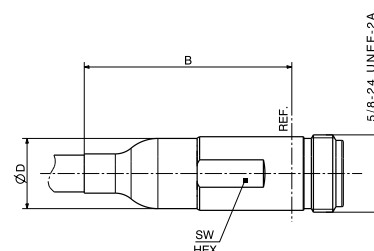

Figure 10



Cable and assembly tools

Use our online tools for fast and efficient calculation and configuration or contact your HUBER+SUHNER partner for specific information.

1. EVALUATE with our eCatalogue

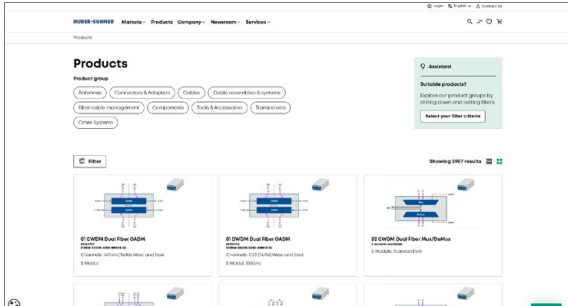

Choose suitable cables by using our “eCatalogue”.

<https://www.hubersuhner.com/en/shop/products/4707>

2. CALCULATE with the assembly calculator

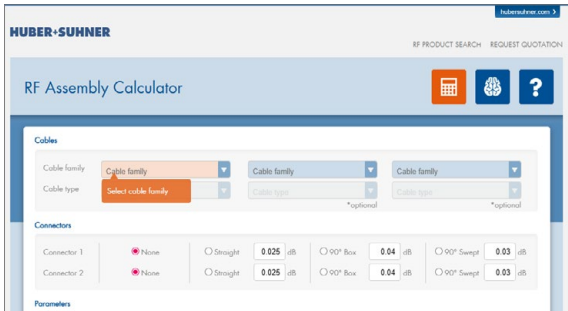

Compare the suitable products and calculate the electrical performance by using the "RF assembly calculator".

<https://rfcablecalc.hubersuhner.com/>

3. CONFIGURE with the SUCOFLEX 500 Configurator

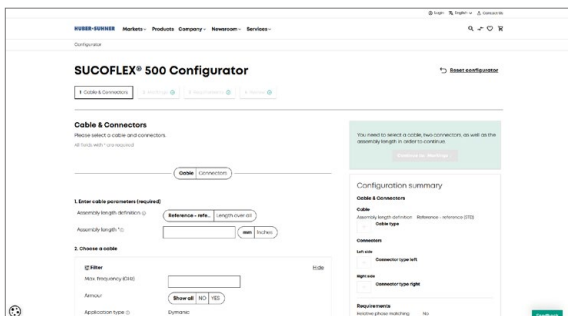

Create a customized SUCOFLEX 500 assembly by using the “SUCOFLEX 500 Configurator”.

<https://www.hubersuhner.com/en/shop/configure/00000000091000071>

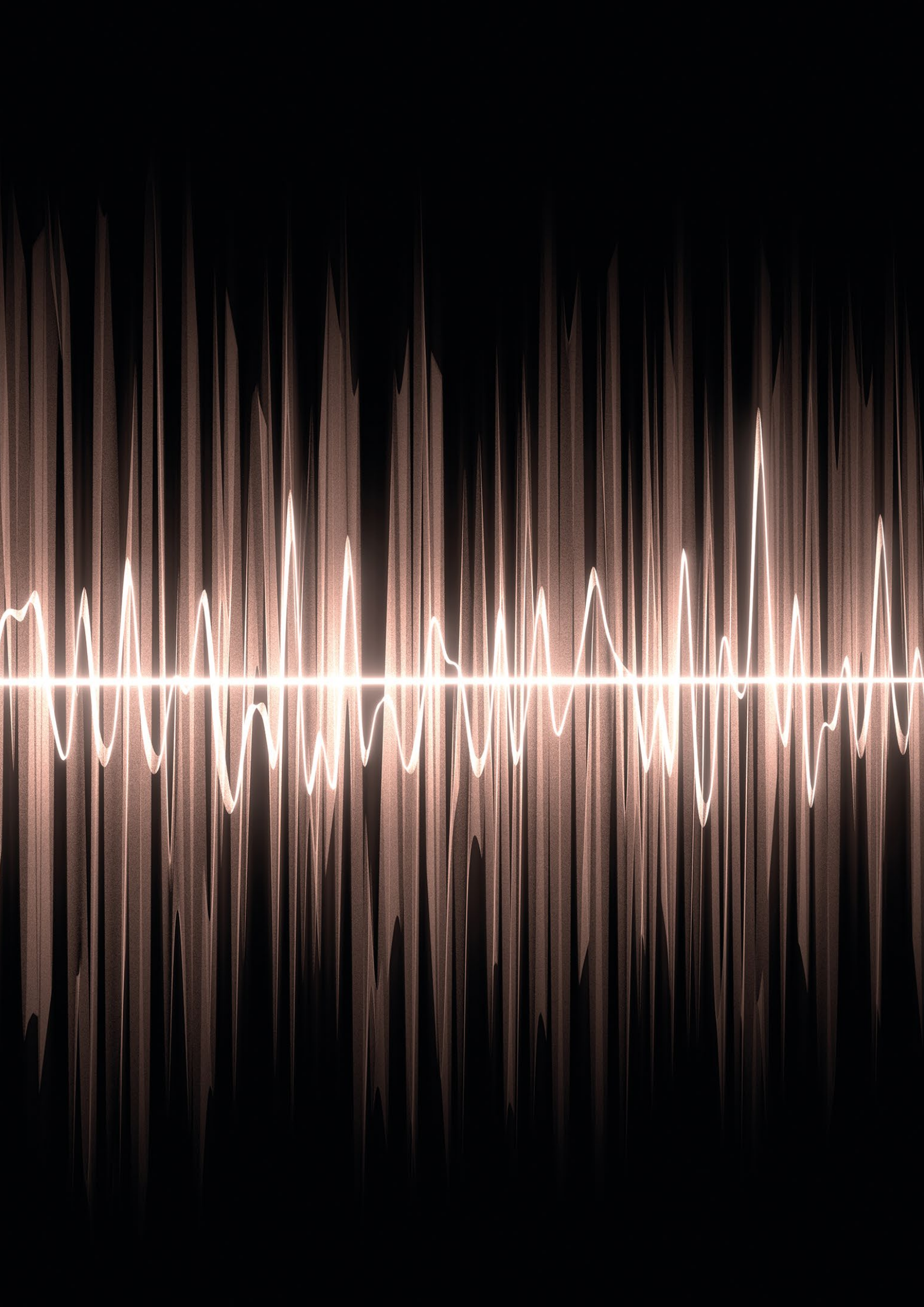

SUCOFLIGHT™



SUCOFLIGHT™ is a fully qualified family of hermetically sealed flexible RF coaxial assemblies for mission critical military, airborne, and other demanding applications. It incorporates a vapor barrier seal to meet rapid acceleration and altitude changes of most stringent airborne applications. It utilizes standardized connector entries with field replaceable connector interface heads, which are interchangeable between the SUCOFLIGHT cables.

SUCOFLIGHT™ 100 Series

SUCOFLIGHT™ is a fully qualified family of hermetically sealed flexible RF coaxial assemblies for mission critical military, airborne, and other demanding applications. It incorporates a vapor barrier seal to meet rapid acceleration and altitude changes of most stringent airborne applications. It utilizes standardized connector entries with field replaceable connector interface heads, which are interchangeable between the SUCOFLIGHT cables.



Product features

- Impedance 50 Ω
- Operating frequency range up to 18 GHz
- Vapor barrier construction supports operational longevity under severe environmental conditions
- All connectors designed with safety wire holes
- Low insertion loss and outstanding shielding effectiveness

Available Cable Connectors

Compatible connectors (other connectors may be made available upon request)

SMA
TNC
N

Construction

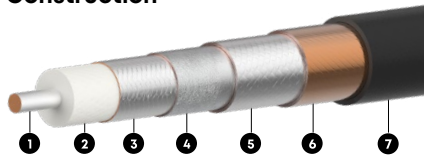

Cable	Inner conductor ①	Dielectric ②	Outer conductor ③	Barrier ④	Outer braid ⑤	Barrier ⑥	Jacket ⑦
SUCOFLIGHT™ 123	CuAg wire	PTFE	CuAg wire	Aluminum/ Polyimide Tape	CuAg wire	Vapor Barrier	Nomex

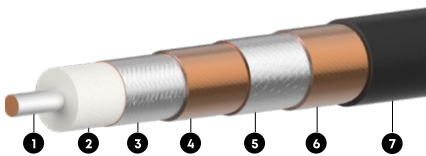

Cable	Inner conductor ①	Dielectric ②	Outer conductor ③	Barrier ④	Outer braid ⑤	Barrier ⑥	Jacket ⑦
SUCOFLIGHT™ 134	CuAg wire	PTFE	CuAg wire	Vapor Barrier	CuAg wire	Vapor Barrier	Nomex

Cable	Operating Frequency GHz	Velocity (nominal) %	Weight (nominal) g/m	Static Min. Bend Radius mm	Impedance Ω	Temp. Range °C
SUCOFLIGHT™ 123	18	77	68	22.9	50	-55 to +200
SUCOFLIGHT™ 134	18	80	143	48.3	50	-55 to +200

SUCOFLIGHT™ 100 Series

Attenuation (dB/m) vs Frequency (GHz)

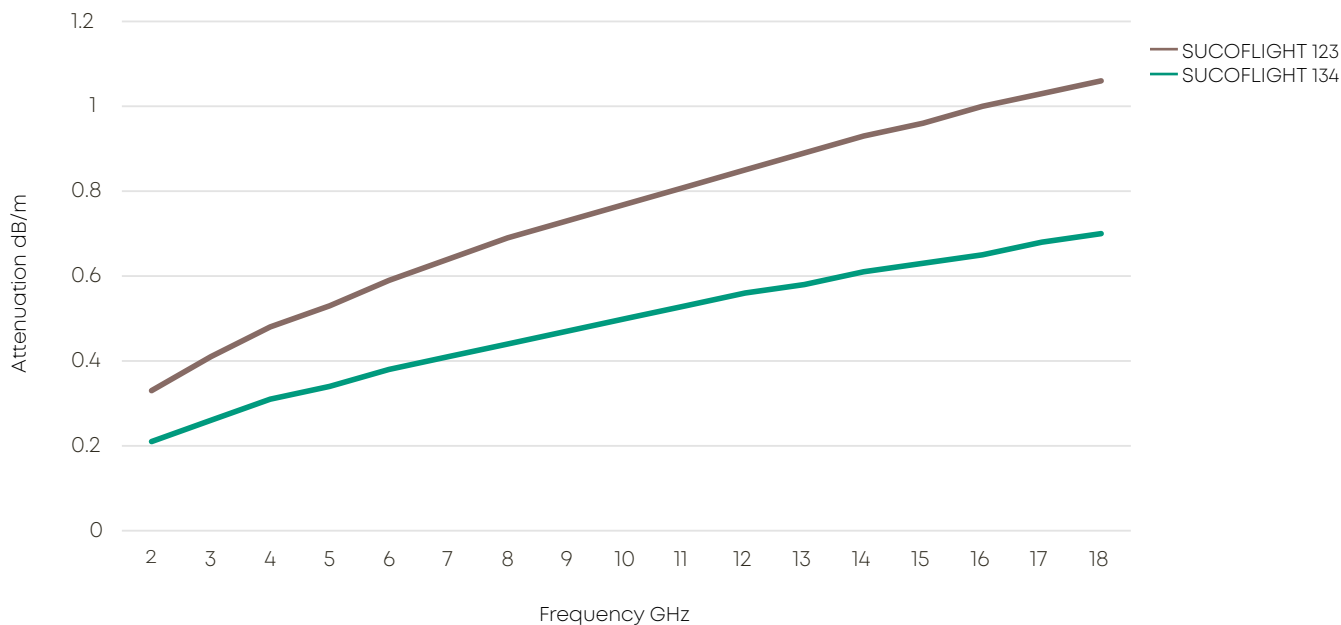

Connectors and Accessories

Item Number	Part Description	Additional Description
85197924	SUCOFLIGHT 123	Cable, 0.230 in / 5.8mm O.D.
85203917	SUCOFLIGHT 134	Cable, 0.340 in / 8.6mm O.D.
85224460	11_VLN-50-4-1/199	VLN Plug conn, straight (SUCOFLIGHT 123)
85241214	11_VLN-50-6-1/199	VLN Plug conn, straight (SUCOFLIGHT 134)
85223781	33_SMA-VLN-50-1/199	SMA Plug to VLN Jack adaptor, straight
85227044	31_SMA-VLN-50-1/199	SMA Jack to VLN Jack adaptor, straight
85224548	33_TNC-VLN-50-1-199	TNC Plug to VLN Jack adaptor, straight
85225051	31_TNC-VLN-50-1-199	TNC Jack to VLN Jack adaptor, straight
85227053	33_N-VLN-50-1-199	N Plug to VLN Jack adaptor, straight
85227305	31_N-VLN-50-1-199	N Jack to VLN Jack adaptor, straight
85246306	53_SMA-VLN-50-1-199	SMA Plug to VLN Jack adaptor, 90 deg
85225279	53_TNC-VLN-50-1-199	TNC Plug to VLN Jack adaptor, 90 deg
85228872	53_N-VLN-50-1-199	N Plug to VLN Jack adaptor, 90 deg
85239780/81	AT-1257VLN-PIA1 / P2A2	Tool, Plier, VLN interface
85240169	AT-1257VLN-TR	Tool, Torque

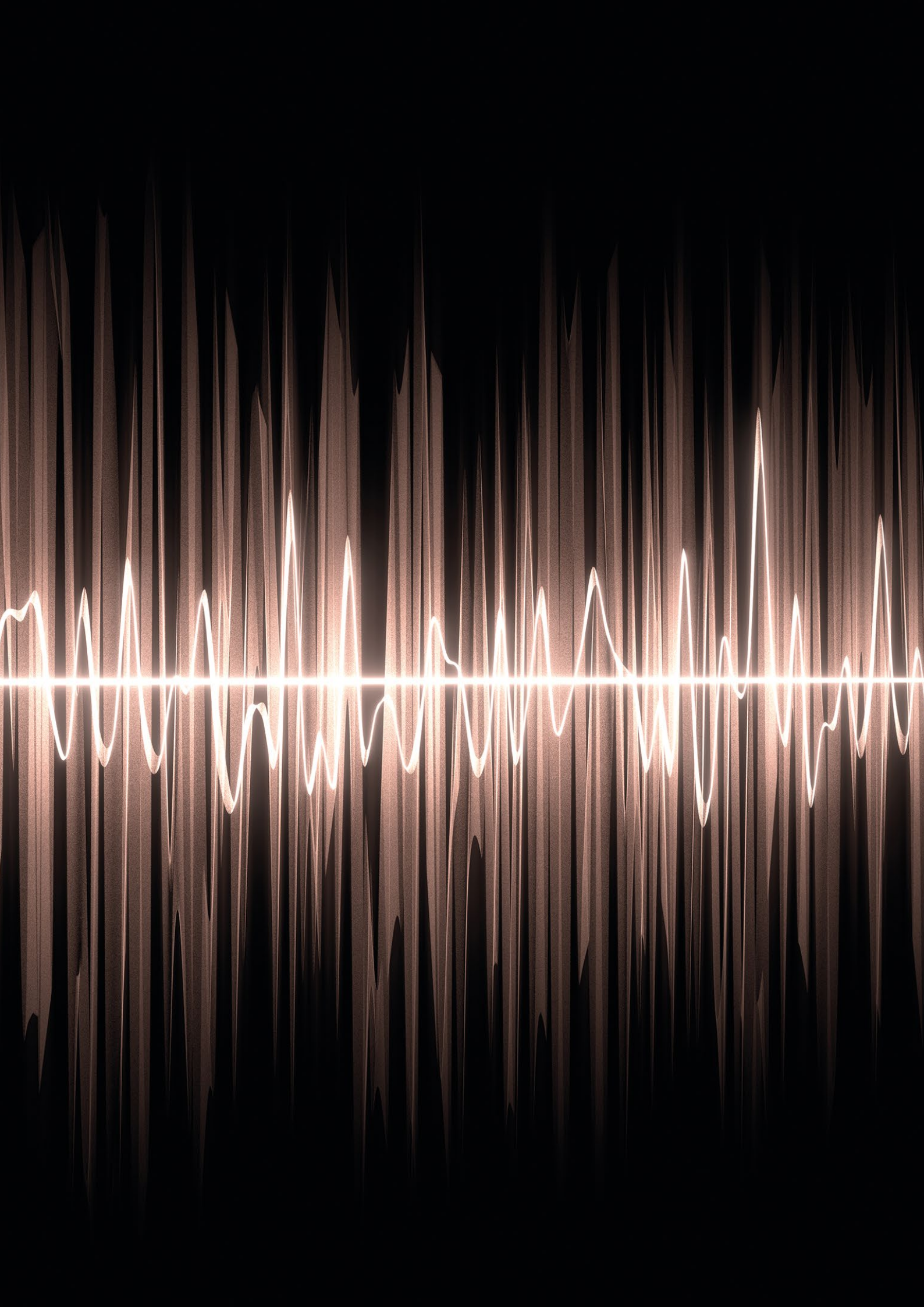

Low profile assemblies

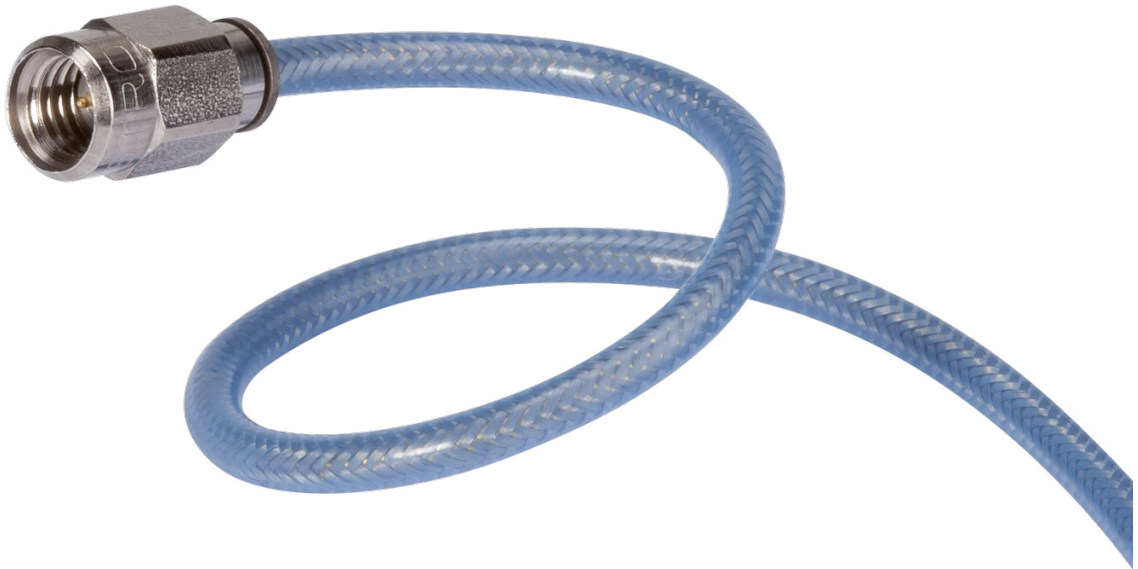

Qualified, low profile microwave cable assemblies

MINIBEND is a truly flexible coaxial cable assembly which is designed for use in low profile, internal, point-to-point interconnections between RF modules within communications systems. MINIBEND replaces custom semi-rigid cables with standard flexible cables, eliminating the need for predefined custom lengths and bend configurations. MINIBEND provides you with a preassembled and tested high performance, cost-effective alternative in a variety of standard lengths and connector configurations.

MINIBEND

Low profile, high performance microwave coaxial cable assemblies

- Frequency range up to 65 GHz
- Triple shielded for high isolation
- Eliminates need for costly right angle connectors
- Direct replacement for 0.086 inch semi-rigid cables



MINIBEND L

Low profile, high performance low loss microwave coaxial cable assemblies

- Frequency range up to 50 GHz
- Triple shielded for high isolation
- Microporous dielectric for 30 % lower insertion
- Direct replacement for 0.086 inch semi-rigid cables

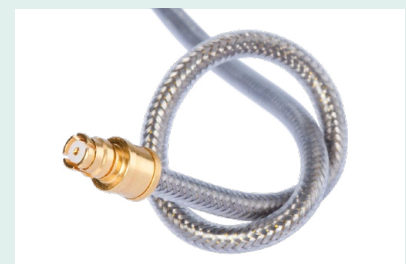

MICROBEND

Ultra low profile, high performance, microwave coaxial cable assemblies

- Frequency range up to 90 GHz
- Triple shielded for high isolation
- Direct replacement for 0.047 inch semi-rigid cables
- Guaranteed 10 lbs (45 N) pull force



MINI141

Low profile, high performance ultra low loss microwave cable assemblies

- Frequency range up to 40 GHz
- Triple shielded for high isolation
- Eliminates need for costly right angle connectors
- Direct replacement for 0.141 inch semi-rigid cables



MICROBEND L

Minibend cable in a smaller package.

- Applications up to 65 GHz
- Microporous dielectric for 20% lower insertion loss than Microbend
- Improved phase stability compared to standard Microbend
- Higher power handling compared to standard Microbend



MINI250H

Five-shielded cable construction that withstands the harsh conditions of spaceflight applications.

- Frequency range up to 26GHz
- Eliminates need for costly right angle connectors
- Minimum bend radius 0.75 inches (19.05 mm)
- Guaranteed 25 lbs (111 N) pull force

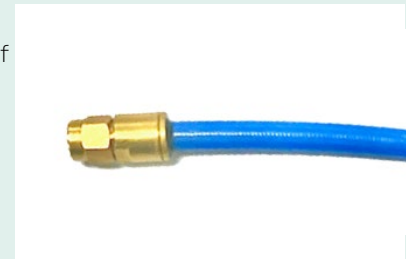

NANO BEND

Smallest diameter cable assembly for low-profile, internal, point-to-point interconnections between RF modules within communications systems.

- Frequency range up to 110GHz
- Eliminates need for costly right angle connectors
- Minimum bend radius 0.20 inches (5.08 mm)



MINIBEND™

High performance/high pull strength microwave coaxial cable assembly

Product description

MINIBEND is a truly flexible coaxial cable assembly which is designed for use in low profile, internal, point-to-point interconnections between RF modules within communications systems. MINIBEND replaces 0.086 inch custom semi-rigid cables with standard flexible cables, eliminating the need for predefined custom lengths and bend configurations. MINIBEND provides you with a preassembled and tested high performance, cost-effective alternative in a variety of standard lengths and connector configurations.

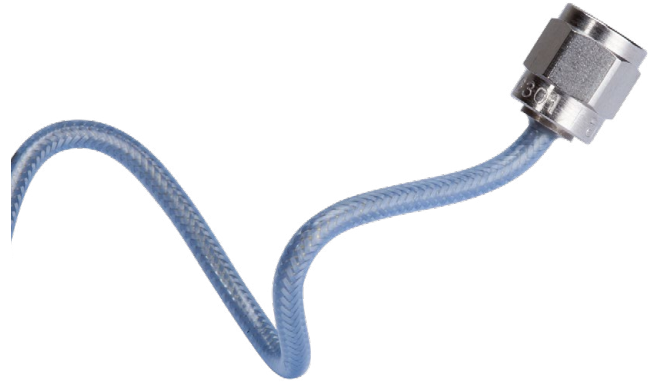

Product features

- Impedance 50 Ω
- Applicable up to 65 GHz
- Direct replacement for 0.086 inch semi-rigid cables
- Stock delivery on standard lengths

Recommended connectors

MINIBEND	SMA, SSMA, SK, SMP, 2.4 mm, 1.85 mm
	Other connectors available on request

Construction

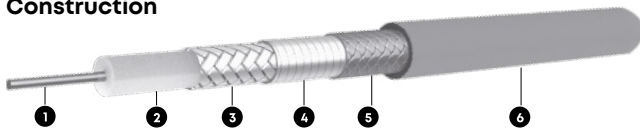

Cable	Inner conductor ①	Dielectric ②	Outer conductor ③	Barrier ④	Outer braid ⑤	Jacket ⑥	Outer diameter mm
32081	CuAg wire	PTFE	CuAg flat wire braid	aluminium/ polyimide tape	stainless steel	FEP	2.5
32081S	StCuAg wire	PTFE	CuAg flat wire braid	aluminium/ polyimide tape	stainless steel	FEP	2.5

Technical data

Cable	Operating frequency	Velocity	Weight	Min. bending radius for ± 180°	Temperature range
	GHz	%	g /m	mm	° C
32081/32081S	65	70.3	14.9	5.08	-55 to +200

Assembly	MINIBEND	MINIBEND A	MINIBEND E	MINIBEND K	MINIBEND KS	MINIBEND KV	MINIBEND QG
Connector A	SMA (m)	SSMA (m)	SMA (m), fully captivated	SK (m)	SK (m)	2.4 mm (m)/ 1.85 mm (m)	2.4 mm (m) gold plated BeCu
Connector B	SMA (m)	SSMA (m)	SMA (m), fully captivated	SK (m)	SMP (f)	SK (m)	2.4 mm (m) gold plated BeCu

Assembly	MINIBEND S	MINIBEND 2S	MINIBEND V	MINIBEND VG	MINIBEND WR
Connector A	SMA (m)	SMP (f)	2.4 mm/1.85 mm (m)	1.85 mm (m) gold plated BeCu	SMA (m)
Connector B	SMP (f)	SMP (f)	2.4 mm/1.85 mm (m)	1.85 mm (m) gold plated BeCu	SMA (m)

MINIBEND™

Attenuation (nominal values at +25 °C ambient temperature)

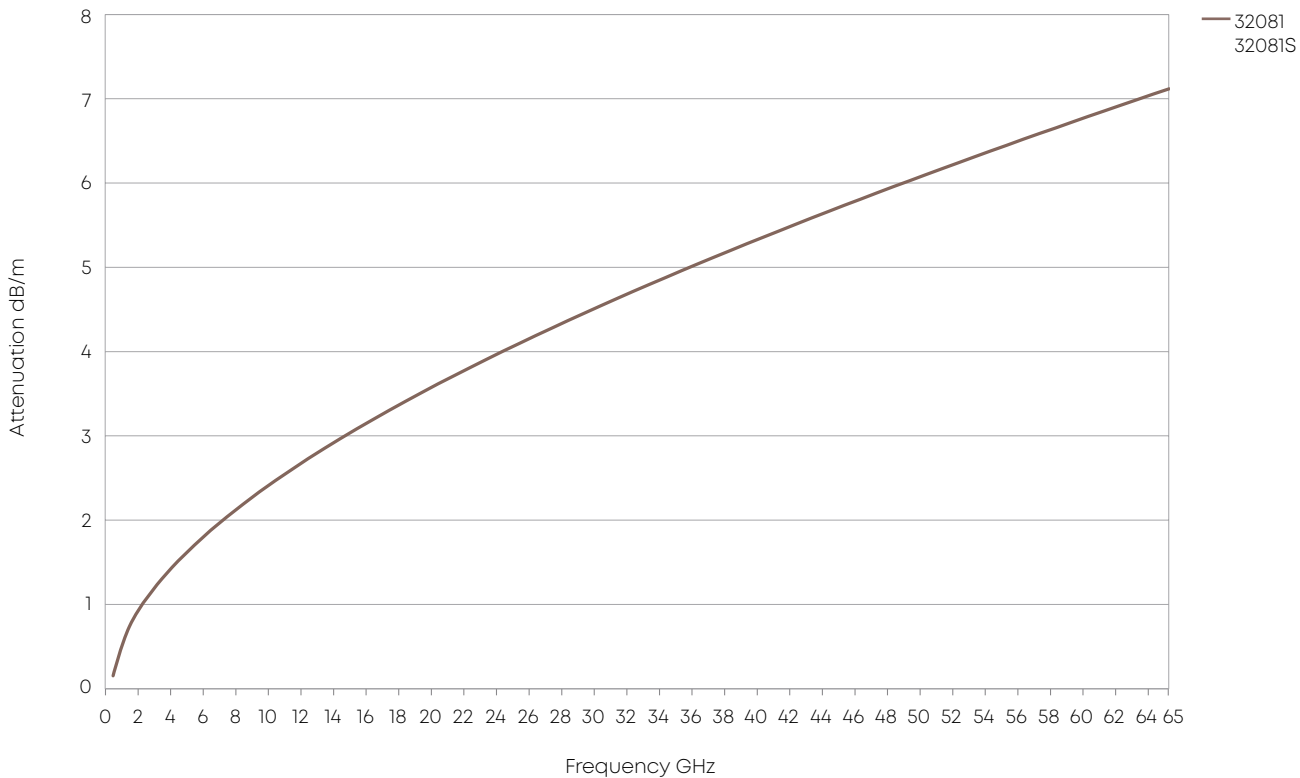

Power handling (maximum values at 25 °C ambient temperature and sea level)

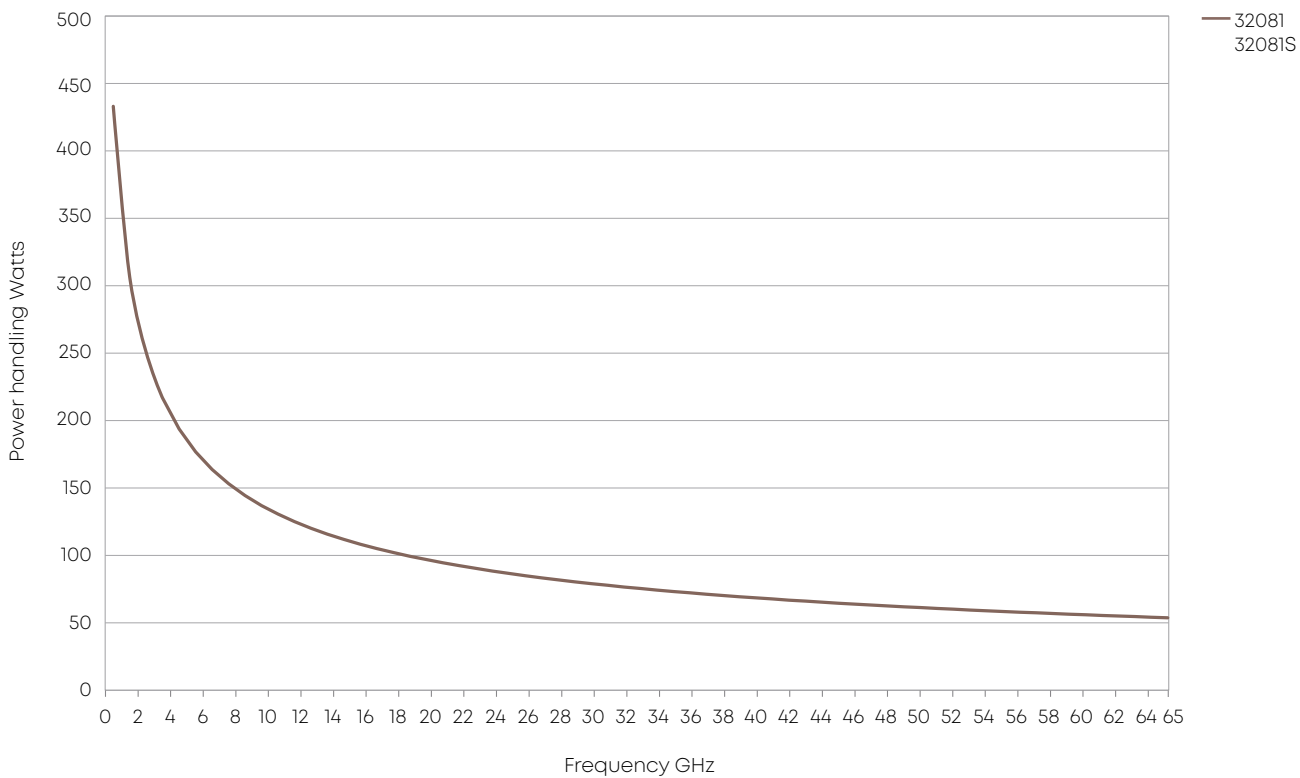

MINIBEND™

Available Connectors

		MINIBEND
SMA	Straight Male	29094CR-32-81 29094CR-32-91
	R/A Male	29200CR-32-81
	Straight Female	29092CR-32-81
	Bulkhead Female	29088CR-32-81 29141CR-32-91VP
	Flanged Female	29156CR-32-81
SMK (2.9)	Straight Male	29094KCR-32-81 29094KCR-32-91
	Straight Female	29092KCR-32-81
	Bulkhead Female	29088KCR-32-81
SMP	Bulkhead Male	29474C2R-32-81
	Straight Female	29473CR-32-81
	R/A Female	29477-32-81
	Flanged Female	29477F2-32-81
SMPM	Bulkhead Male	29972C2R-32-81
	Straight Female	29981CR-32-81 29981CR-32-91
	R/A Female	29983HT-32-81
	Straight Female	29971TCR-32-81
SSMA	Straight Male	29112CR-32-81 29112CR-32-91
	R/A Male	29111-32-81 29111-32-91
PC 2.4mm	Straight Male	29898CR-32-81-1 29898CR-32-91
	Straight Female	29881CR-32-81
PC 1.85mm	Straight Male	29890CR-32-81-1
TNC	Straight Male	29714-32-81
N	Straight Male	29080-32-81
MCX	Straight Male	29966CR-32-81
	R/A Male	29958-32-81-3
MMCX	Straight Male	29959CR-32-81
	R/A Male	29954-32-81ALT3
	Straight Female	29939-32-81-2T
MMPX	Straight Male	29430CR-32-81

MINIBEND™ L

High performance/high pull strength, low loss microwave coaxial cable assembly

Product description

MINIBEND L is an enhanced, low loss version of the MINIBEND flexible coaxial cable assembly with increased phase stability and power handling capacity which is designed for use in low profile, internal, point-to-point interconnections between RF modules within communications systems. MINIBEND L replaces 0.086 inch custom semi-rigid cables with standard flexible cables providing 30 % lower attenuation and eliminating the need for predefined custom lengths and bend configurations. MINIBEND L provides you with a pre-assembled and tested high performance, cost-effective alternative in a variety of standard lengths.



Product features

- Impedance 50 Ω
- Applicable up to 50 GHz
- Direct replacement for 0.086 inch semi-rigid cables
- Stock delivery on standard lengths
- Microporous dielectric for 30 % lower insertion loss, improved phase stability and higher power handling

Recommended connectors

MINIBEND L	SMA, SSMA, SMP
	Other connectors available on request

Construction

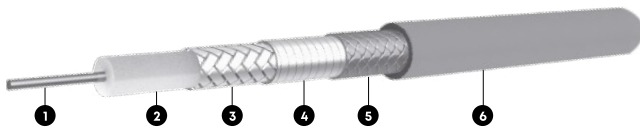

Cable	Inner conductor ①	Dielectric ②	Outer conductor ③	Barrier ④	Outer braid ⑤	Jacket ⑥	Outer diameter
32024	CuAg wire	PTFE micro-porous	CuAg flat wire braid	aluminium/ polyimide tape	stainless steel	FEP	mm 2.7

Technical data

Cable	Operating frequency	Velocity	Weight	Min. bending radius for ± 180°	Temperature range
	GHz	%	g / m	mm	° C
32024	50	76.0	16.4	5.08	-55 to +200

Assembly	MINIBEND L	MINIBEND LS	MINIBEND L2S	MINIBEND LA
Connector A	SMA (m)	SMA (m)	SMP (f)	SSMA (m)
Connector B	SMA (m)	SMP (f)	SMP (f)	SSMA (m)

MINIBEND™ L

Attenuation (nominal values at +25 °C ambient temperature)

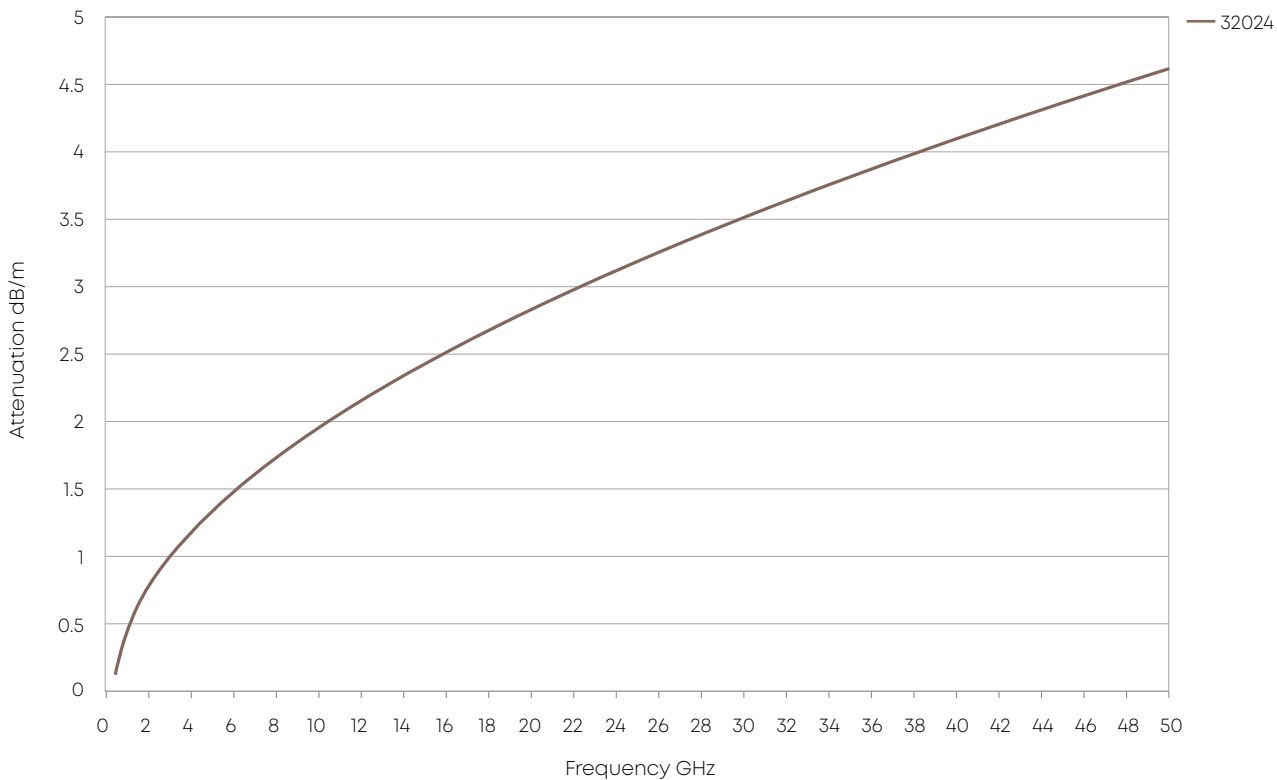

Power handling (maximum values at 25 °C ambient temperature and sea level)

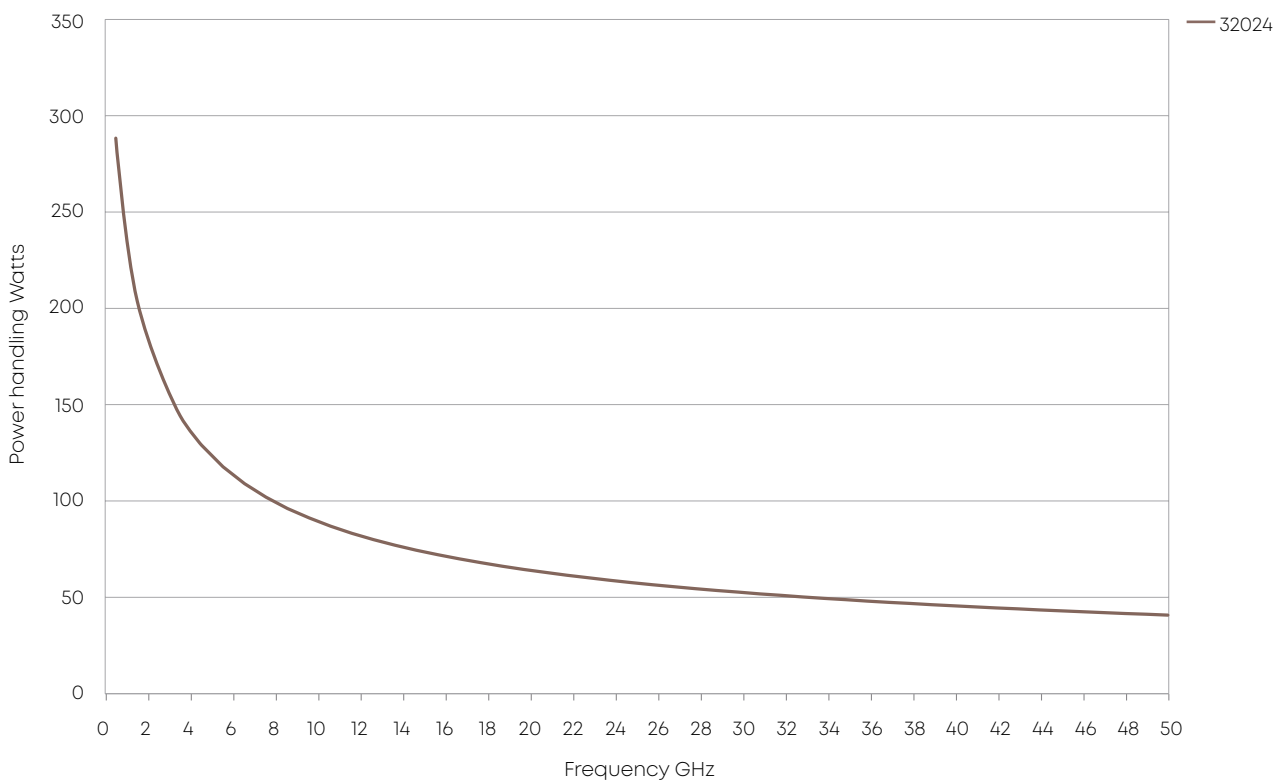

MINIBEND™ L

Available Connectors

		MINIBEND L
SMA	Straight Male	29094CR-32-24 29094CR-32-87
	R/A Male	29200CR-32-24
	Straight Female	29092CR-32-24
	Bulkhead Female	29088CR-32-24
	Flanged Female	29056CR-32-24
SMK (2.9)	Straight Male	29094KCR-32-24 29094KCR-32-87
	Straight Female	29092KCR-32-24
	Bulkhead Female	29141KCR-32-24
SMP	Straight Female	29473CR-32-24
	R/A Female	29477-32-24-3
	Flanged Female	29477F2-32-24
SMPM	Straight Female	29981CR-32-24
	R/A Female	29983-32-24
SMPM-T	Straight Female	29971TCR2-32-24
SSMA	Straight Male	29112CR-32-24
	R/A Male	29111-32-24
PC 2.4mm	Straight Male	29898CR-32-24 29898CR-32-87
PC 1.85mm	Straight Male	29890CR-32-87

MICROBEND™

High performance/high pull strength microwave coaxial cable assembly

Product description

MICROBEND assemblies provide you with a standard preassembled and tested high performance, cost-effective truly flexible alternative to 0.047 inch custom semi-rigid cable assemblies, eliminating the need for predefined custom lengths and bend configurations. MICROBEND features include 35 % lower loss than 0.047 inch semi-rigid cable, a minimum bend radius of 1.52 mm (0.060 inch) and triple shielding for high isolation. MICROBEND assemblies are available with a wide range of connector interfaces. All MICROBEND assemblies are available only in a ruggedised version.



Product features

- Impedance 50 Ω
- Applicable up to 67 GHz
- Stock delivery on standard lengths
- 35 % lower insertion loss than 0.047 inch semi-rigid cables

Recommended connectors

MICROBEND	SMA, SSMA, SK, SMP, SMPM, SMPM-T, 1.85 mm
	Other connectors available on request

Construction

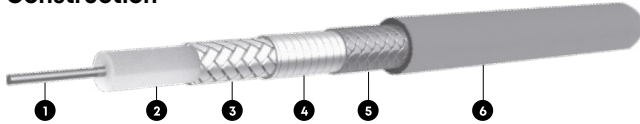

Cable	Inner conductor ①	Dielectric ②	Outer conductor ③	Barrier ④	Outer braid ⑤	Jacket ⑥	Outer diameter mm
32041	CuAg wire	PTFE	CuAg flat wire braid	aluminium/polyimide tape	stainless steel	FEP	2.0

Technical data

Cable	Operating frequency GHz	Velocity %	Weight g / m	Min. bending radius for ± 180° mm	Temperature range ° C
32041	90	70.3	11.9	1.50	-55 to +200

Assembly	MICRO-BEND R	MICRO-BEND AR	MICRO-BEND KR	MICRO-BEND KMR	MICROBEND KMTR	MICROBEND KV	MICRO-BEND MR
Connector A	SMA (m)	SSMA (m)	SK (m)	SK (m)	SK (m)	SK (m)	SMA (m)
Connector B	SMA (m)	SSMA (m)	SK (m)	SMPM (f)	SMPM -T(f)	1.85 mm (m) gold plated BeCu	SMPM (f)

Assembly	MICROBEND 2MR	MICRO-BEND MTR	MICRO-BEND 2MTR	MICROBEND MVR	MICROBEND SR	MICRO-BEND 2SR	MICROBEND V
Connector A	SMPM (f)	SMA (m)	SMPM -T(f)	SMPM (f)	SMA (m)	SMP (f)	1.85 mm (m) gold plated BeCu
Connector B	SMPM (f)	SMPM -T(f)	SMPM -T(f)	1.85 mm (m) gold plated BeCu	SMP (f)	SMP (f)	1.85 mm (m) gold plated BeCu

MICROBEND™

Attenuation (nominal values at +25 °C ambient temperature)

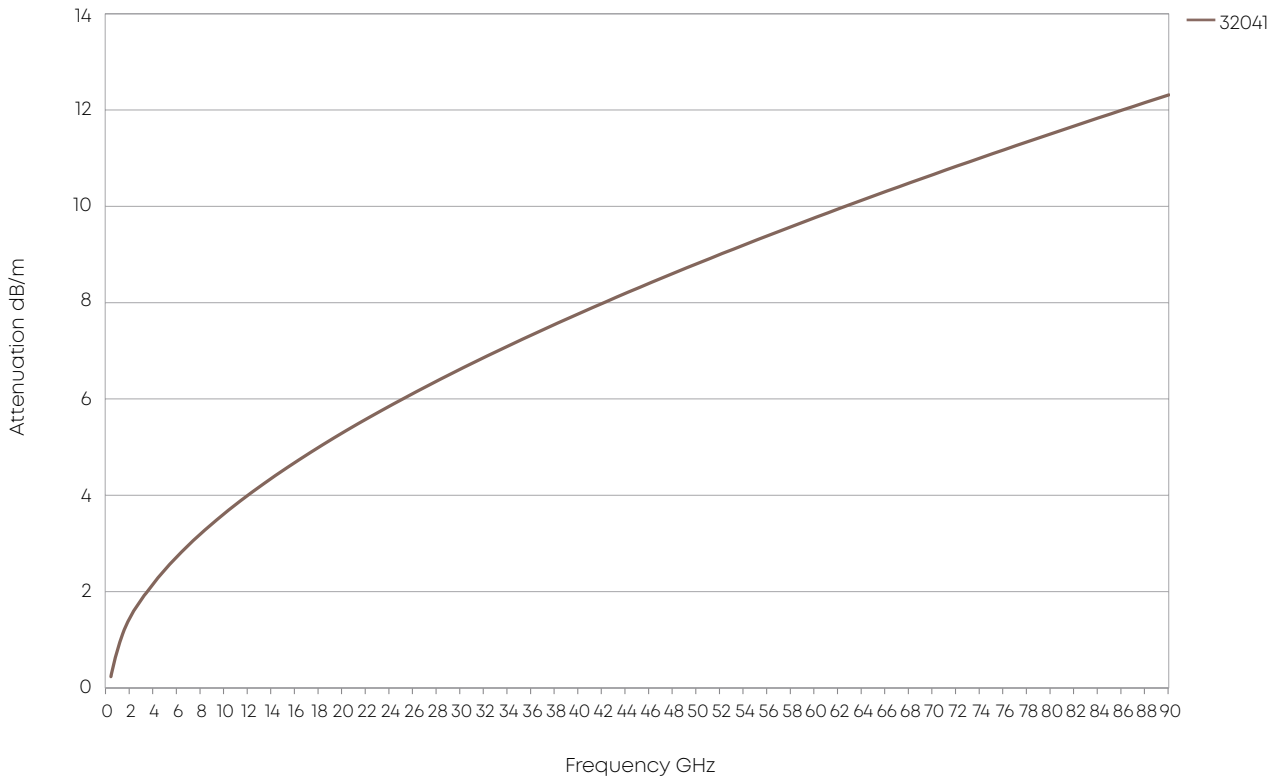

Power handling (maximum values at 25 °C ambient temperature and sea level)

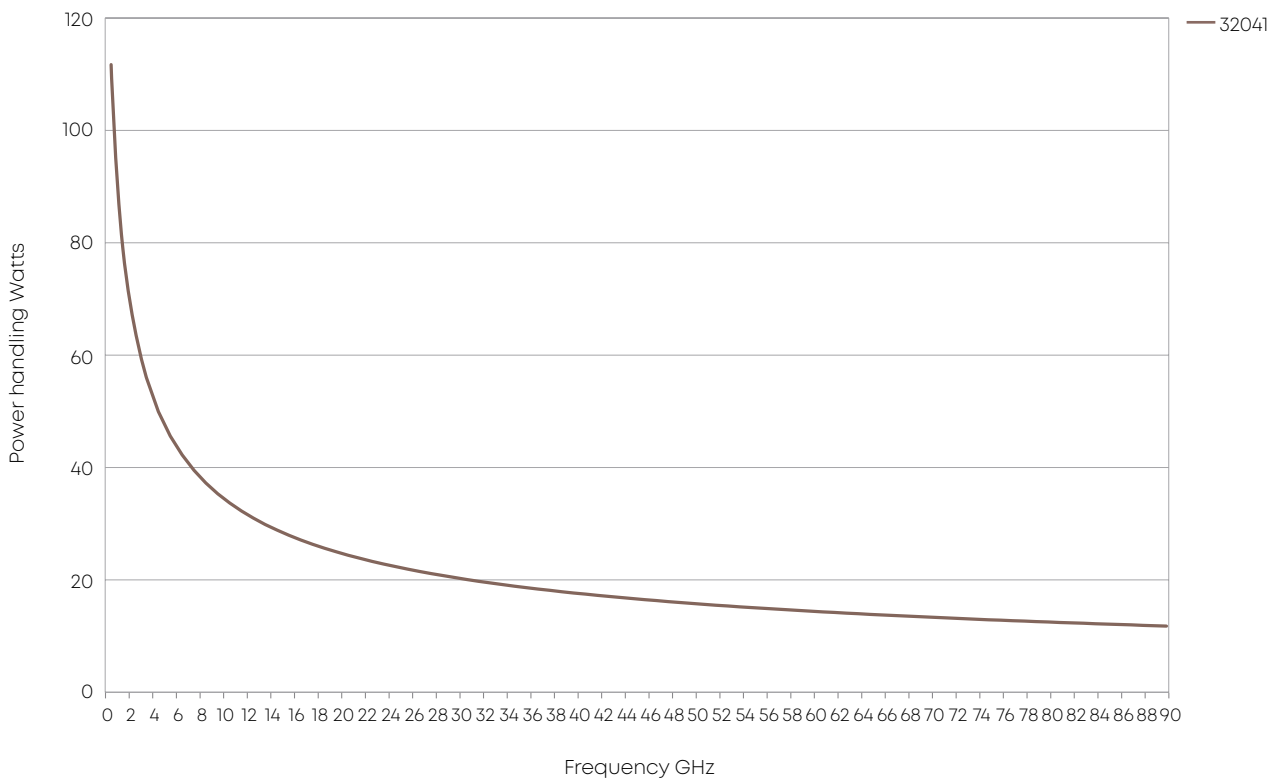

MICROBEND™

Available Connectors

		MICROBEND
SMA	Straight Male	29094CR-32-41
	Straight Female	29092CR-32-41
	Bulkhead Female	29088CR-32-41
	Flanged Female	29156CR-32-41
SMK (2.9)	Straight Male	29094KCR-32-41
	Straight Female	29092KCR-32-41
	Bulkhead Female	29088KCR-32-41
	Flanged Female	29156KCR-32-41
SMP	Straight Female	29573CR-32-41
	R/A Female	29477-32-41
SMPM	Bulkhead Male	29972C2R-32-41
	Straight Female	29981CR-32-41
	R/A Female	29973-32-41
SMPM-T	Straight Female	29981TCR-32-41
SMPS	Bulkhead Male	29171SVCR3-32-41
SSMA	Straight Male	29112CR-32-41
	Bulkhead Female	29102CR-32-41
PC 2.4mm	Straight Male	29898CR-32-41-1
	Straight Female	29981BHCR-32-41
PC 1.85mm	Straight Male	29890CR-32-41-1
PC 1.0mm	Straight Male	29840CR-32-41-2
MMCX	Straight Male	29959CR-32-41
	R/A Male	29954-32-41
MMPX	Straight Male	29430CR-32-41

MICROBEND™ L

MICROBEND L is an enhanced, low loss version of the MICROBEND flexible coaxial cable assembly which is designed for use in low profile, internal, point-to-point interconnections between RF modules within communications systems. MICROBEND L eliminates the need for predefined custom lengths and bend configurations. MICROBEND L provides you with a preassembled and tested high performance, cost-effective alternative in a variety of standard lengths.



Product features

- Impedance 50 Ω
- Applications up to 65 GHz
- Flexible alternative for 0.047 inch semi-rigid cables
- Microporous dielectric for 20% lower insertion loss than Microbend
- Improved phase stability compared to standard Microbend
- Higher power handling compared to standard Microbend

Available Cable Connectors

Compatible connectors (other connectors may be made available upon request)

SMA
SMK
SMP
SMPM
SMPM-T
SSMA
PC 2.4mm
PC 1.85mm
MMPX

Construction

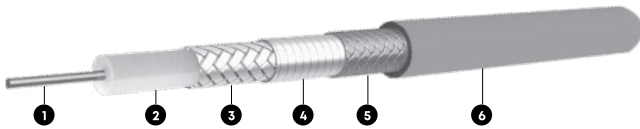

Cable	Inner Conductor ①	Dielectric ②	Outer Conductor ③	Barrier ④	Outer Braid ⑤	Jacket ⑥	Outer Diameter
32085	CuAg Wire	Micro-porous PTFE	CuAg flat wire braid	Aluminum / Polyimide Tape	Stainless Steel Braid	FEP	2 mm

Cable	Operating Frequency	Velocity (nominal)	Weight (nominal)	Static Min. Bend Radius	Impedance	Temp. Range
	GHz	%	g/m	mm	Ω	°C
32085	65	75.5	10.4	5.1	50	-55 to +200

MICROBEND™ L

Available Connectors

		MICROBEND L
SMA	Straight Male	29094CR-32-85
	Bulkhead Female	29088CR-32-85
SMK (2.9)	Straight Male	29094KCR-32-85
SMP	Bulkhead Male	29474BH4C5R-32-85
	Straight Female	29573CR-32-85
SMPM	Straight Female	29971CR-32-85
SMPM-T	Straight Female	29971TCR-32-85
	R/A Female	29973-32-85
SMPS	Bulkhead Male	29171SVCR3-32-85
PC 2.4mm	Straight Male	29898CR-32-85
PC 1.85mm	Straight Male	29890CR-32-85
	Bulkhead Female	29891BH2CR-32-85
MMPX	Straight Male	29430CR-32-85

MICROBEND™ L

Attenuation dB/m vs Frequency (GHz) of 32024E

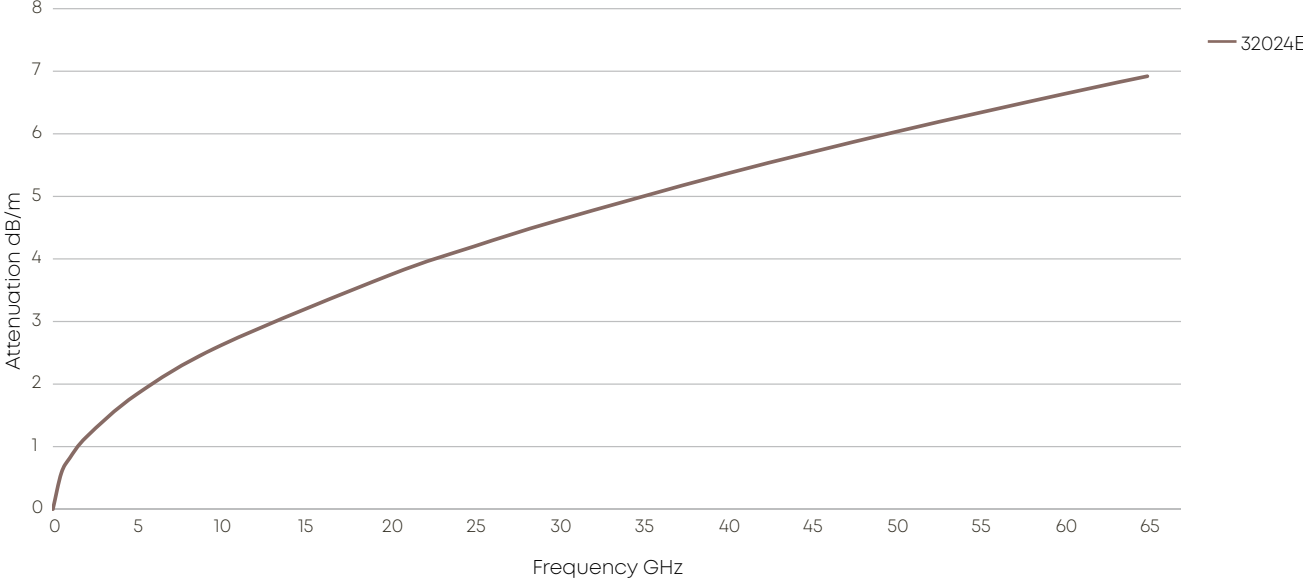

MINI141™

High performance/high pull strength, low loss microwave coaxial cable assembly

Product description

MINI141 is an enhanced, low loss version of the MINIBEND flexible coaxial cable assembly with increased phase stability and power handling capacity which is designed for use in low profile, internal, point-to-point interconnections between RF modules within communications systems. MINI141 replaces 0.141 inch custom semi-rigid cables with standard flexible cables providing 20 % lower attenuation and eliminating the need for predefined custom lengths and bend configurations. MINI141 provides you with a preassembled and tested high performance, cost-effective alternative in a variety of standard lengths.

Product features

- Impedance 50 Ω
- Applicable up to 40 GHz
- Direct replacement for 0.141 inch semi-rigid cables
- Stock delivery on standard lengths
- Microporous dielectric for 20 % lower insertion loss, improved phase stability and higher power handling

Construction

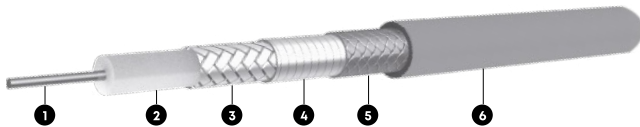

Cable	Inner conductor ①	Dielectric ②	Outer conductor ③	Barrier ④	Outer braid ⑤	Jacket ⑥	Outer diameter
							mm
32022	CuAg wire	PTFE microporous	CuAg flat wire braid	aluminium/polyimide tape	stainless steel	FEP	3.7

Technical data

Cable	Operating frequency	Velocity	Weight	Min. bending radius for ± 180°	Temperature range
	GHz	%	g / m	mm	° C
32022	40	76.3	31.3	8.40	-55 to +200

Assembly	MINI141	MINI141 K	MINI141 N	MINI141 T	MINI141 W
Connector A	SMA (m)	SK (m)	N (m)	ATNC (m)	SMA (m)
Connector B	SMA (m)	SK (m)	N (m)	ATNC (m)	SMA (m)



Recommended connectors

mini141	SMA, N, TNCA, SK
	Other connectors available on request

MINI141™

Attenuation (nominal values at +25 °C ambient temperature)

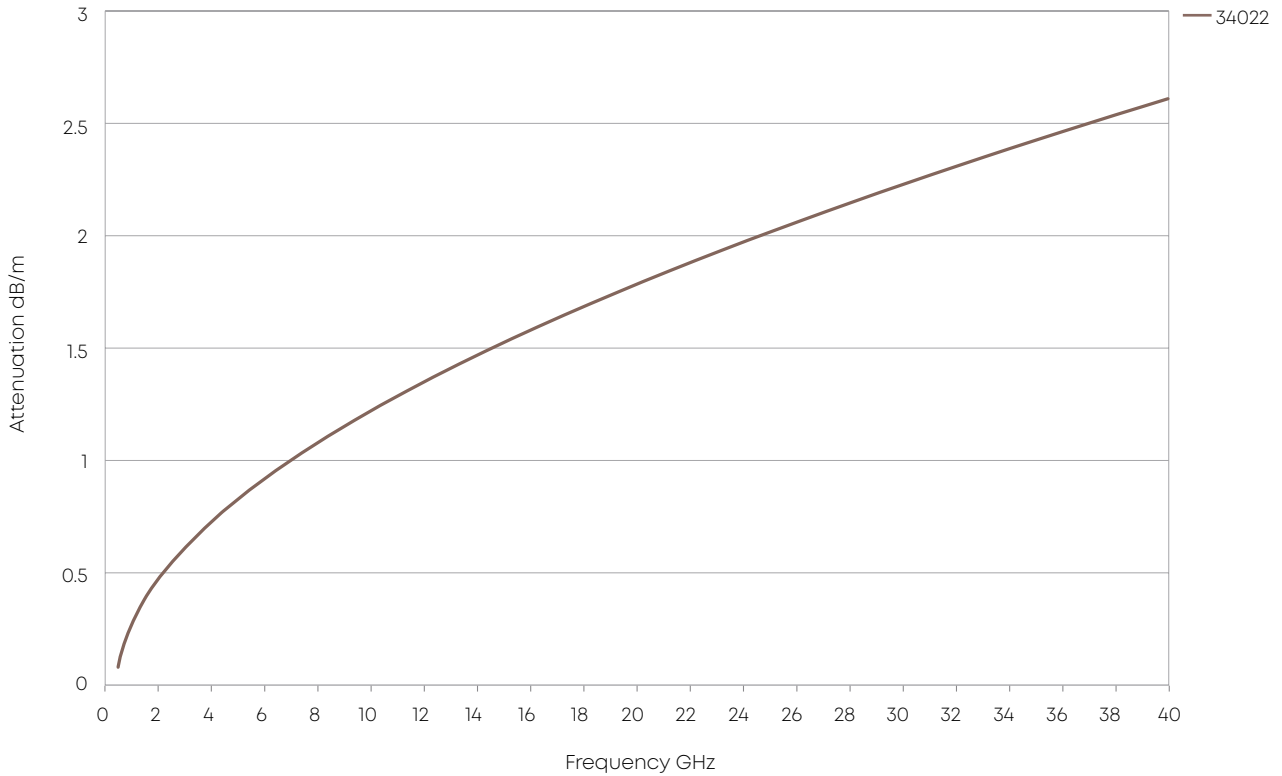

Power handling (maximum values at 25 °C ambient temperature and sea level)

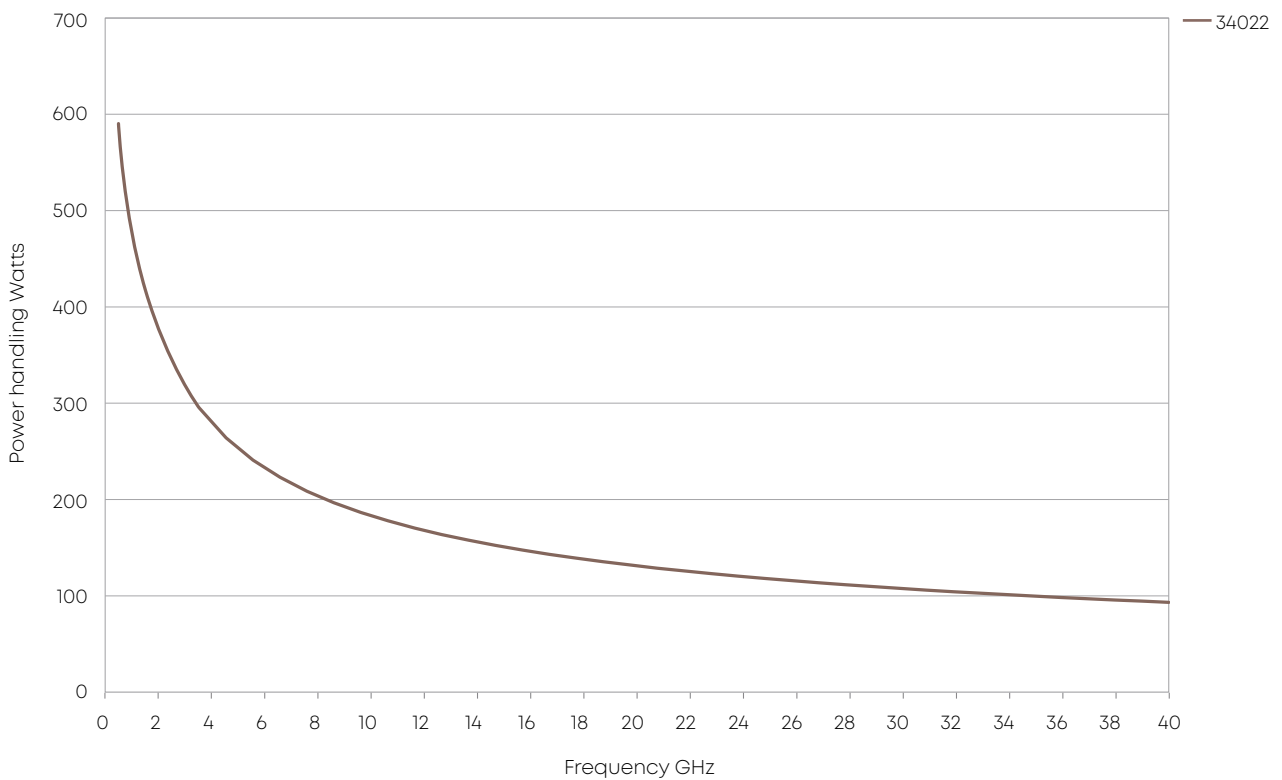

MINI141™

Available Connectors

	MINI141
SMA	29094CR-32-22
	29094CR-32-21
	29200CR-32-22
	29092CR-32-22
	29088CR-32-22
	29141EMI2CR-32-21
SMK (2.9)	29094KCR-32-22
	29094KCR-32-21
	29092KCR-32-22
SMP	29474CR3-32-22
	29473CR-32-22
SMP-L	21_SMPL-50-3-1
SSMA	29112CR-32-22
	29112CR-32-21
PC 2.4mm	29898CR-32-22
	29898CR-32-21H
PSM	11_PSM-50-3-3
ATNC	29882CR-32-22
	29887CR-32-22
N	29080CR-32-22
	29039C2R-32-22
	29082CR-32-22

NANO BEND™

What is it? NANO BEND™ is a new and flexible, high-frequency coaxial cable assembly that is designed for use in low profile, internal, point-to-point interconnections between RF modules within communications systems. As the newest entrant found in the MINIBEND™ family of standard flexible cables, NANO BEND brings the same capabilities you depend on, but now in the smallest diameter available.

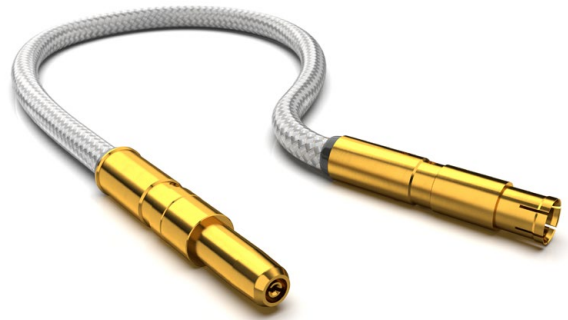

Product features

- Impedance 50 Ω
- Applicable up to 110 GHz
- Stock delivery on standard lengths
- Connections available that are found nowhere else in our current product offerings, including: Size 12 SMPM, Size 16 SMPS, Nanominiature Connections (pictured at right), VITA 67.1/2 SMPM, VITA 67.3 SMPM and SMPS, and more

Available Cable Connectors

Compatible connectors (other connectors may be made available upon request)

HUBER+SUHNER®-designed Nanominiature Connections, both Plug and Jack
SMA and SMA Bulkhead
SMPM
SMP
SK
Size 12 SMPM
Size 16 SMPS
HUBER+SUHNER-designed and TE®-compatible NANO RF Connections, both Plug and Jack
VITA 67.1/2 and VITA 67.3 SMPM Connector
VITA 67.3 SMPS Connector

Construction

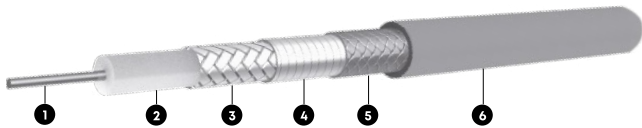

Cable	Inner Conductor ①	Dielectric ②	Outer Conductor ③	Barrier ④	Outer Braid ⑤	Jacket ⑥	Outer Diameter
32061SE	CuAg (SPC) Wire	Extruded PTFE	CuAg (SPC) flat wire braid	Aluminum / Polyimide Tape	Stainless Steel Braid	FEP	1.6 mm

Cable	Operating Frequency	Velocity (nominal)	Weight (nominal)	Static Min. Bend Radius	Impedance	Temp. Range
	GHz	%	g/m	mm	Ω	°C
32061SE	110	70.3	14.9	5.08	50	-55 to +200

NANOBEND™

Attenuation (dB/m) vs Frequency (GHz) of 32061SE

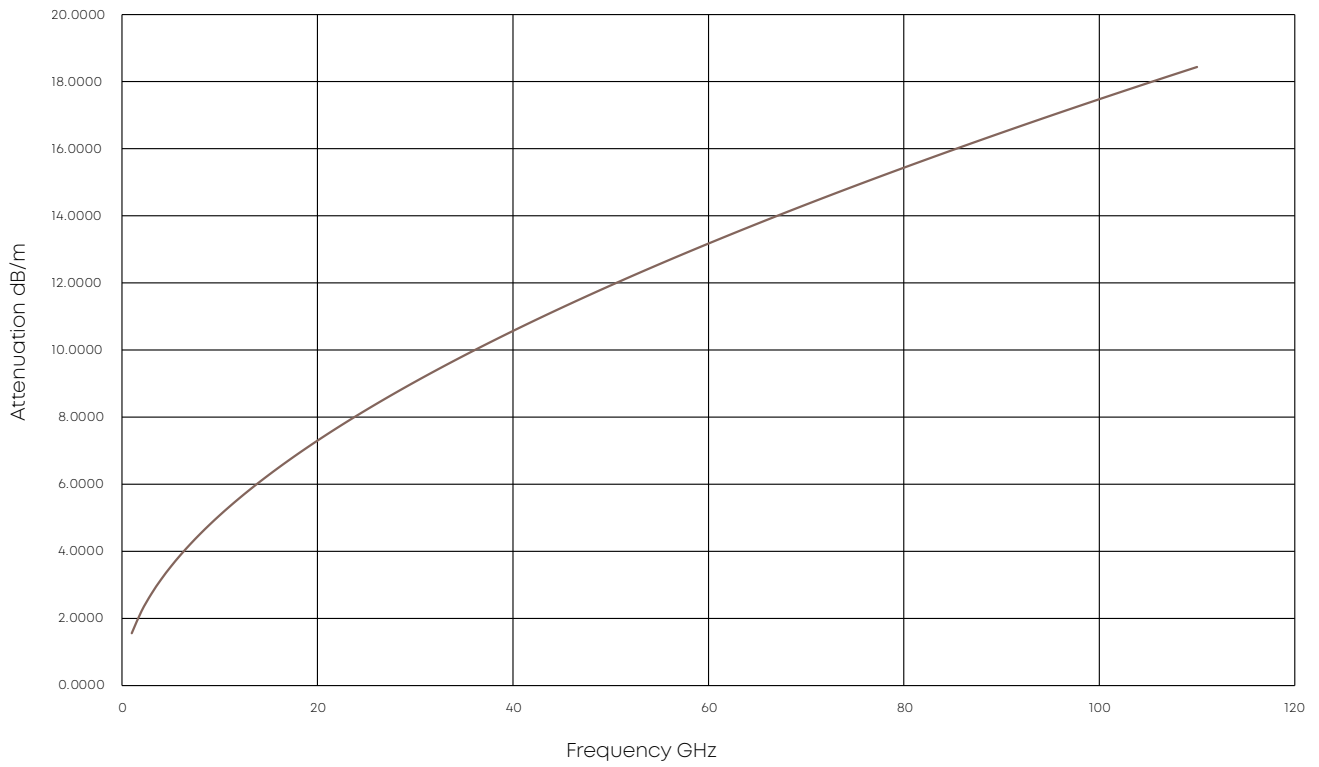

NANO BEND™

Available Connectors

		NANO BEND
SMA	Straight Male	29094CR-32-6ISE
	Straight Female	29092CR-32-6ISE
	Bulkhead Female	29141CR-32-6ISE
SMK (2.9)	Straight Male	29094KCR-32-6ISE
	Straight Female	29092KCR-32-6ISE
	Bulkhead Female	29142KCR-32-6ISE
SMP	Bulkhead Male	29474CR5-32-6ISE
	Straight Female	29573CR-32-6ISE
SMPM	Bulkhead Male	29972C2R-32-6ISE
	Straight Female	29981CR-32-6ISE
	R/A Female	29973-32-6ISE
SMPM-T	Bulkhead Male	29976BHIC2R-32-6ISE
	Straight Female	29981TCR-32-6ISE
SMP3	Straight Female	29171CR-32-6ISE
SMPS	Bulkhead Male	29171SVCR3-32-6ISE
MMCX	Straight Male	29959CR-32-6ISE
	R/A Male	29954-32-6ISE

MINI250™ H

What is it? MINI250™ H is for payload integration cabling, helping transmit antenna signals while providing the ability to complete long runs between cable subsystems. It is a significant step-function and low-loss leader in the mold of the MINI141™ H cable. We now complement the MINIBEND™ family with a design that allows us to compete in longer length, high-power, low-loss cables, with a size above the MINI141™ H offering. We help solve your need for products that withstand extreme conditions with low-profile and low-loss solutions.



Product features

- Impedance 50 Ω
- Stock delivery on standard lengths
- Connections available include SMA and TNC
- Quint-shielded design to help protect the solderless junction
- MINI250™ H is applicable up to 26.5 GHz for SMA, and 18 GHz for TNC

Available Cable Connectors

Compatible connectors (other connectors may be made available upon request)

SMA

TNC

Construction

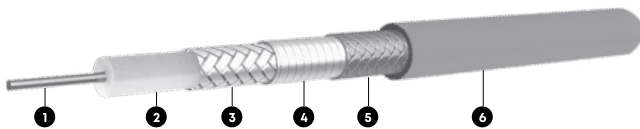

Cable	Inner Conductor ①	Dielectric ②	Outer Conductor ③	Barrier ④	Outer Braid ⑤	Jacket ⑥	Outer Diameter
32031E	Silver Coated Copper	Extruded PTFE	CuAg (SPC) flat wire braid	Aluminum / Polyimide Tape	Stainless Steel Braid	FEP	22.5 mm

Cable	Operating Frequency	Velocity (nominal)	Weight (nominal)	Static Min. Bend Radius	Impedance	Temp. Range
	GHz	%	g/m	mm	Ω	°C
32031E	26.0	77.3	74.4	19	50	-55 to +200

MINI250™ H

Attenuation (dB/m) vs Frequency (GHz) of 32031

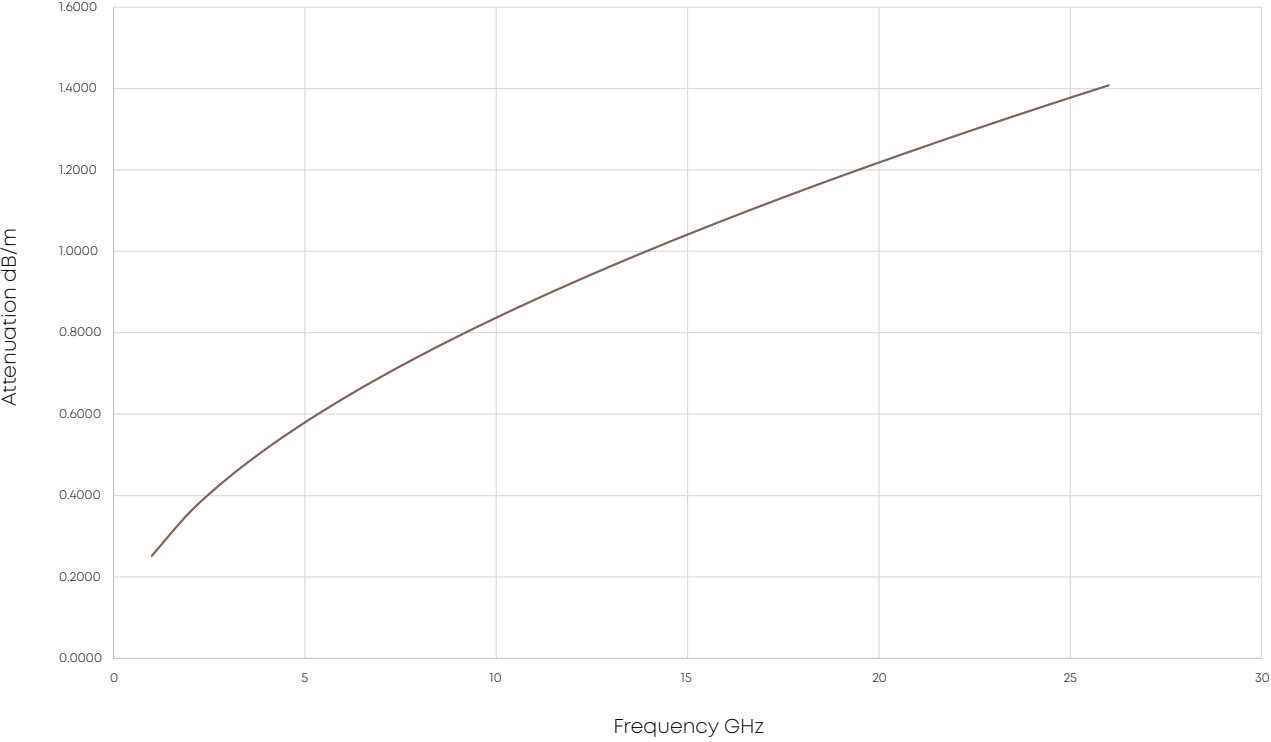

MINI250™ H

Available Connectors

		MINI250 H/HB
SMA	Straight Male	29094CR-32-31 29094CR-32531
	R/A Male	29200PVCR-32531HE
PSM	Straight Male	11_PSM-50-4-2
TNC	Straight Male	29714CR-32-31
		29714CR-32531

Test assemblies



Test leads for Test+Measurement set-ups

The best measurement set-up is only as good as its weakest link. To obtain reliable and reproduceable measurement results, particular care must be taken in selecting the components required for the measurement set-up.

HUBER+SUHNER's extensive range of high quality test leads are matched to the various needs in the field of test and measurement. All these products are distinguished by their high performance and stable characteristics – the result of years of experience in the development and production of radio frequency components.

Sucotest 145

Reliable microwave test cable assemblies for consistent, repeatable measurements up to 145 GHz.



Sucotest 110

Reliable microwave test cable assemblies for consistent, repeatable measurements up to 110 GHz.



Sucotest 18A

The test lead for harsh environment up to 18 GHz – precision at a constant high level.



Sucotest 18

The test lead up to 18 GHz – for the highest standard of measurement.

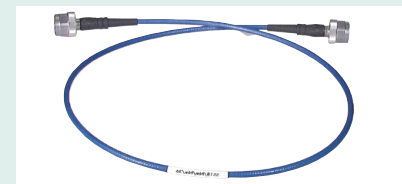

TL-8A

The test lead for component and equipment testing up to 8 GHz.



TL-P

High flexible test lead for passive intermodulation (PIM) and return loss for frequency up to 4 GHz.



Sucotest 145

microwave test cable assemblies

Reliable microwave cable assemblies for consistent, repeatable measurements

- Dependable electrical performance up to 145 GHz
- Superior return loss
- Excellent amplitude and phase stability with flexure, crush and torque resistance
- Rugged construction for extended service life
- Rugged construction for extended service life
- Stock assemblies available in 6, 12-inch lengths, with male and female 0.8 mm connectors, absolute time delay matched +/- 1ps



Ruggedized design for exceptional performance

Connectors	0.8 mm (male/female)
Velocity of propagation (%)	76
Return loss (dB)	Typ. 16.0 Min. 14.0
Insertion loss (dB/m)	Typ. 26.9
Amplitude stability vs. flexure (dB)	Typ. ± 0.20 Max. ± 0.25
Phase stability vs. flexure (°)	Typ. ± 20 Max. ± 25
Flex cycles	Typ. 300

Cable assembly configurations available from stock

Cable assembly configurations available from stock	Item	Connector types	Length	Return loss	Insertion loss	Absolute time delay matched
PMAST145/11PC08/11PC08/6in	85271037	0.8 mm male / 0.8 mm male	6 inch / 152 mm	min. 14.0 dB	max. 4.97 dB	± 1ps
PMAST145/11PC08/11PC08/12in	85271039		12 inch / 305 mm		max. 8.74 dB	
PMAST145/11PC08/21PC08/6in	85271038	0.8 mm male / 0.8 mm female	6 inch / 152 mm		max. 4.97 dB	
PMAST145/11PC08/21PC08/12in	85271040		12 inch / 305 mm		max. 8.74 dB	

Sucotest 110

microwave test cable assemblies

Reliable microwave test cable assemblies for consistent, repeatable measurements

- Dependable electrical performance up to 110 GHz
- Excellent amplitude and phase stability with flexure, crush and torque resistance
- Superior return loss
- Rugged construction for extended service life
- Stock assemblies available in 6, 12, and 18-inch lengths, with male and female 1.0 mm connectors



Ruggedized design for exceptional performance

Connectors	1.0 mm (male/female)
Velocity of propagation (%)	70
Return loss (dB)	Typ. 19.0 Min. 14.7
Insertion loss (dB/m)	Typ. 19.8
Amplitude stability vs. flexure (dB)	Typ. ± 0.15 Max. ± 0.2
Phase stability vs. flexure ($^{\circ}$)	Typ. ± 10 Max. ± 20
Flex cycles	Typ. 15.000

Cable assembly configurations available from stock

Cable assembly configurations available from stock	Item	Connector types	Length	Return loss	Insertion loss
ST110_11PC10_11PC10_6in	85229047	1 mm male / 1 mm male	6 inch / 152 mm	min. 14.7 dB	max. 3.7 dB
ST110_11PC10_11PC10_12in	85229046		12 inch / 305 mm		max. 6.35 dB
ST110_11PC10_11PC10_18in	85229048		18 inch / 457 mm		max. 9.0 dB
ST110_11PC10_21PC10_6in	85229043	1 mm male / 1 mm female	6 inch / 152 mm		max. 3.7 dB
ST110_11PC10_21PC10_12in	85229039		12 inch / 305 mm		max. 6.35 dB
ST110_11PC10_21PC10_18in	85229040		18 inch / 457 mm		max. 9.0 dB
ST110_21PC10_21PC10_6in	85229041	1 mm female / 1 mm female	6 inch / 152 mm		max. 3.7 dB
ST110_21PC10_21PC10_12in	85229044		12 inch / 305 mm		max. 6.35 dB
ST110_21PC10_21PC10_18in	85229045		18 inch / 457 mm		max. 9.0 dB

Sucotest 18A

The test lead for harsh environment up to 18 GHz – precision at a constant high level

Product description

Sucotest 18A armoured test assemblies offer excellent electrical performance (low insertion loss combined with unique stability and excellent return loss) for heavy duty, outdoor and harsh environment measurements up to 18 GHz.

Sucotest 18A armoured test assemblies are ideal for testing wireless communication infrastructures, defense and ground systems and in daily use in components and assembly shops.



Product features

- Impedance 50 Ω
- Applicable up to 18 GHz
- High flexibility in spite of armoring
- Phase and loss stability with flexure
- Crush-, torque- and kink-resistant
- Waterproof IP68

Recommended connectors

ST_18A	N, 7/16
--------	---------

Construction

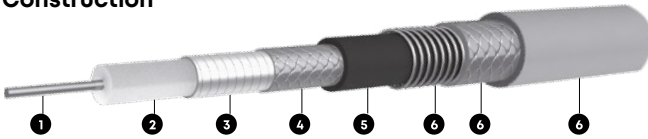

Cable	Inner conductor ①	Dielectric ②	Outer conductor ③ ④	Jacket ⑤	Ruggedisation ⑥	Outer diameter mm
Sucotest_18A	Cu Ag strand-low loss	LD-PTFE	CuAg tape CuSn braid	FEP	stainless steel/PUR, blue	10.3

Technical data

Cable	Operating frequency	Velocity of propagation	Weight	Min. bending radius for ± 180°	Temperature range
	GHz	%	g /m	mm	°C
Sucotest_18A	18	77	175.0	50.0	-40 to +85

Available connectors

Connector	Series, pattern	HUBER+SUHNER type	Cable	Operating frequency GHz	VSWR per connector
7/16	straight cable plug	11_716-403	ST_18A	7.5	1.14
	straight cable jack	21_716-403		7.5	1.14
N	straight cable plug	11_N-468		18	1.14
	straight cable jack	21_N-409		18	1.14

Sucotest 18A

Assemblies data

Return loss	N-N	Min. 19 dB up to 18 GHz
Insertion loss (1'500 mm)	N-N	Max. 2.03 dB up to 18 GHz
Insertion loss (3'000 mm)	N-N	Max. 3.84 dB up to 18 GHz
Return loss	716-716 / N-716	Min. 18 dB up to 7.5 GHz
Insertion loss (1'500 mm)	716-716 / N-716	Max. 1.26 dB up to 7.5 GHz
Insertion loss (3'000 mm)	716-716 / N-716	Max. 2.38 dB up to 7.5 GHz

Mechanical specifications

Waterproof	IP68
Flex life (cycles)	100 000
Connector retention force	> 230 N

Sucotest 18A

Attenuation (nominal values at +25 °C ambient temperature)

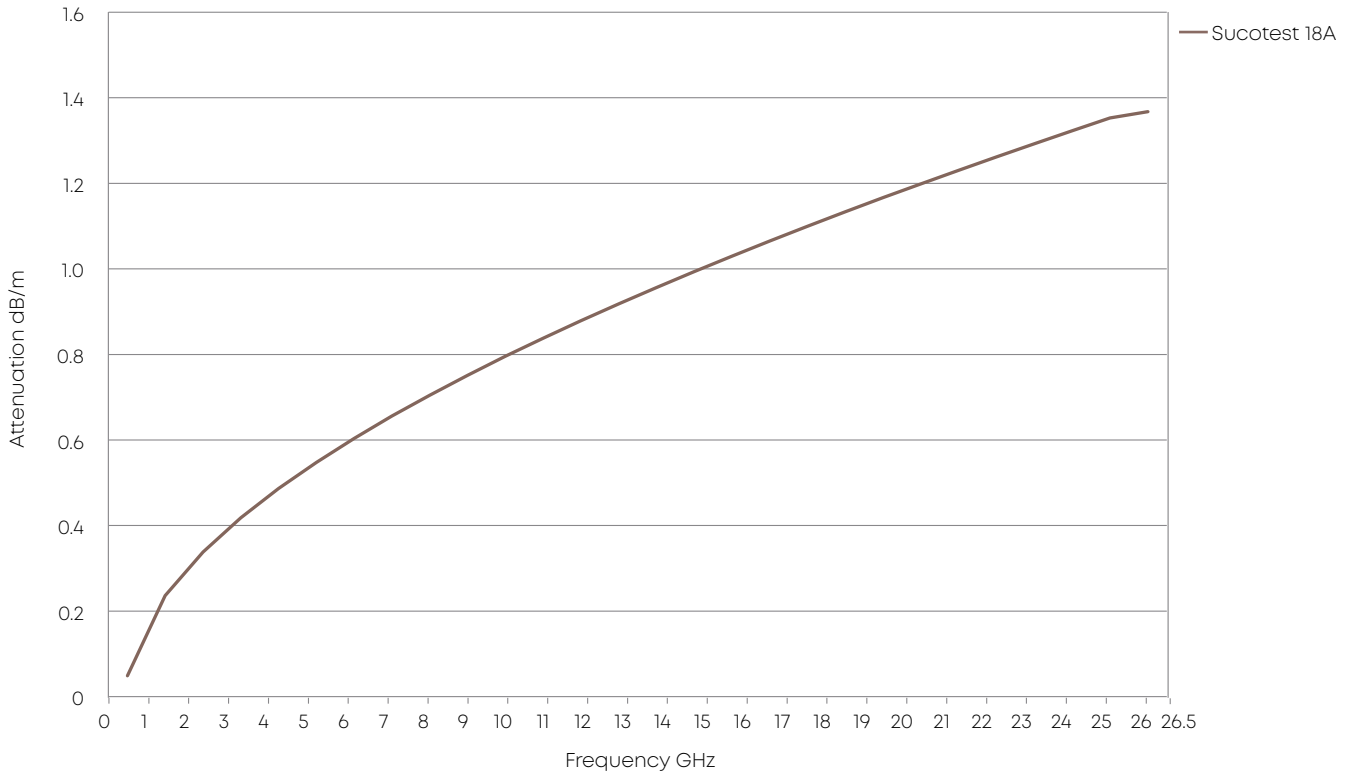

Power handling (maximum values at 25 °C ambient temperature and sea level)

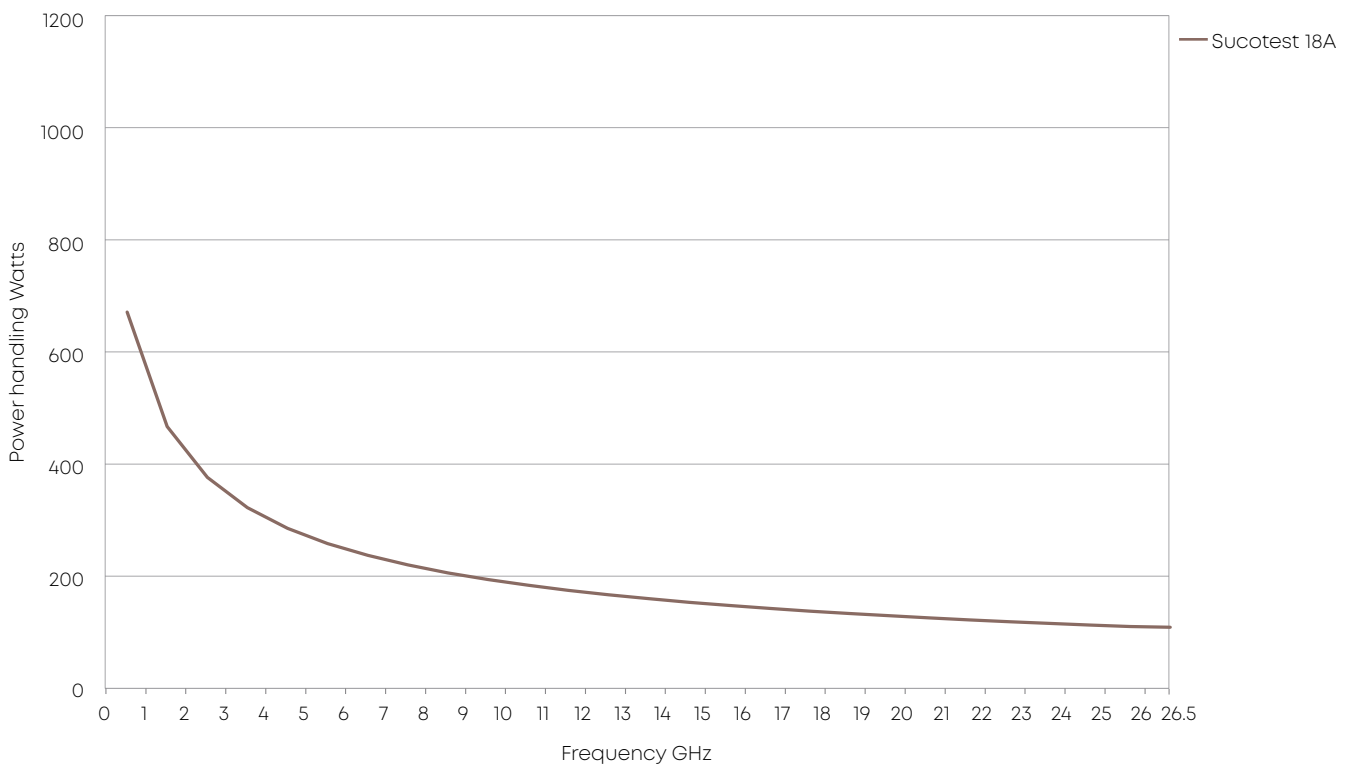

Sucotest 18

The test lead up to 18 GHz – for the highest standard of measurement

Product description

Sucotest 18 cable assemblies feature excellent electrical performance (low insertion loss combined with unique loss stability and excellent return loss).

Sucotest 18 is ideal for daily use in components and assembly shops, test labs and automatic test equipment applications.

Product features

- Impedance 50 Ω
- Applicable up to 18 GHz
- Low insertion loss
- Excellent VSWR
- Unique loss stability
- There is no cable spring back during measurement procedures; the assembly stays in position.

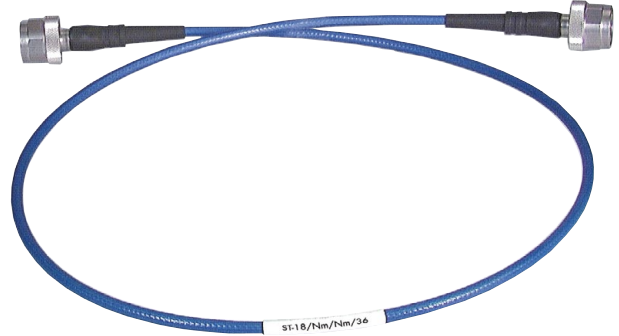

Recommended connectors

ST_18	SMA, N
-------	--------

Construction

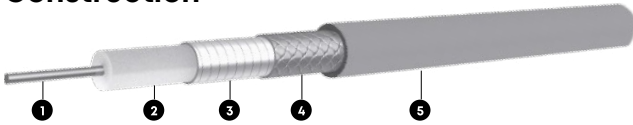

Cable	Inner conductor ①	Dielectric ②	Outer conductor ③ ④	Jacket ⑤	Outer diameter
					mm
Sucotest_18	CuAg wire	LD-PTFE	CuAg tape CuSn braid	FEP, blue	4.6

Technical data

Cable	Operating frequency	Velocity of propagation	Weight	Preferred bending radius	Temperature range
	GHz	%	g /m	mm	°C
Sucotest_18	18	77	53.0	100.0	-55 to +105

Sucotest 18

Stock assemblies

HUBER+SUHNER cable type	Item no.	Assembly length (ref.-ref.) (mm/inch)	Min. Return loss up to 18 GHz (dB)	Max. insertion loss up to 18 GHz (dB)		
ST-18/SMAm/SMAm/36 in	84002061	914/36	19	1.51		
ST-18/Nm/Nm/36 in	84002060					
ST-18/SMAm/Nm/36 in	84004594					
ST-18/SMAm/SMAm/48 in	84003373	1219/48		19	1.95	
ST-18/Nm/Nm/48 in	84003372					
ST-18/SMAm/Nm/48 in	84004006					
ST-18/SMAm/SMAm/72 in	84004007	1829/72			19	2.85
ST-18/Nm/Nm/72 in	84004070					
ST-18/SMAm/Nm/72 in	84004595					

Other lengths on request with minimum order quantity of 50 pcs.

TL-8A

The test lead for component and equipment testing up to 8 GHz

Product description

TL-8A assemblies are designed for testing components or equipments up to 8 GHz with network analyser (NA). This economical assembly family is made with a PE foamed double screened cable and protected with an armouring using a moulded cable entry. The excellent electrical performance combined with a high mechanical endurance is ideal for use in test labs and in operations.

Product features

- Impedance 50 Ω
- Applicable up to 8 GHz
- High mechanical endurance
- Excellent insertion and return loss
- High mating cycle
- N and SMA connector with quick-lock nut
- Excellent performance to price ratio
- Free of halogen



Recommended connectors

TL-8A	SMA, N
	Other connectors available on request.

Construction

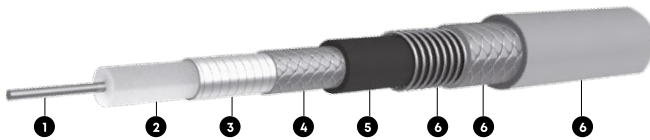

Cable	Inner conductor ①	Dielectric ②	Outer conductor ③ ④	Jacket ⑤	Ruggedisation ⑥	Outer diameter mm
TL-8A	CuAg wire	SPE	CuAg braid	LSFH	stainless steel/PUR, blue	10.3

Technical data

Cable	Operating frequency	Velocity of propagation	Weight	Preferred bending radius	Temperature range
	GHz	%	g /m	mm	°C
TL-8A	8	82	225.0	100.0	-5 to +85

TL-8A – ... -51

Technical data

Return loss ≤ 1'000 mm	Min. 22 dB up to 8 GHz
Return loss ≤ 1'500 mm	Min. 21 dB up to 8 GHz
Return loss ≤ 3'000 mm	Min. 20 dB up to 8 GHz
Attenuation	Typ. 1.24 dB/m @ 8GHz
Waterproof	No gasket on interface
Durability (matings)	> 3000 cycles
Assembly length	Min. 300 mm, max. 3'000 mm

Standard assemblies

HUBER+SUHNER cable type	Item no.	Assembly length (mm)	Min. Return loss up to 8 GHz (dB)	Max. insertion loss up to 8 GHz (dB)
TL-8A-11N-21N-01500-51	85021664	1'500	21	2.15
TL-8A-11N-21N-03000-51	85021665	3'000	20	4.25
TL-8A-11N-11N-01000-51	84236772	1'000	22	1.44
TL-8A-11N-11N-01500-51	85006682	1'500	21	1.20
TL-8A-11N-11N-02000-51	84236774	2'000	20	2.85
TL-8A-11N-11N-03000-51	85014502	3'000	20	4.25
TL-8A-11N-11N-00600-51	84236770	600	22	0.88
TL-8A-11N-11SMA-01000-51	85014642	1'000	22	1.44
TL-8A-11N-11SMA-01500-51	85014643	1'500	21	2.15
TL-8A-11N-11SMA-02000-51	85014644	2'000	20	2.85
TL-8A-11N-11SMA-03000-51	85014645	3'000	20	4.25
TL-8A-11N-11SMA-00600-51	85014641	600	22	0.88
TL-8A-11SMA-11SMA-01000-51	85014637	1'000	22	1.44
TL-8A-11SMA-11SMA-01500-51	85014638	1'500	21	2.15
TL-8A-11SMA-11SMA-02000-51	85014639	2'000	20	2.85
TL-8A-11SMA-11SMA-03000-51	85014640	3'000	20	4.25
TL-8A-11SMA-11SMA-00600-51	85014636	600	22	0.88

Other lengths on request with minimum order quantity of 50 pcs.

TL - 8A - 11 N - 11 SMA - 01500 - 51

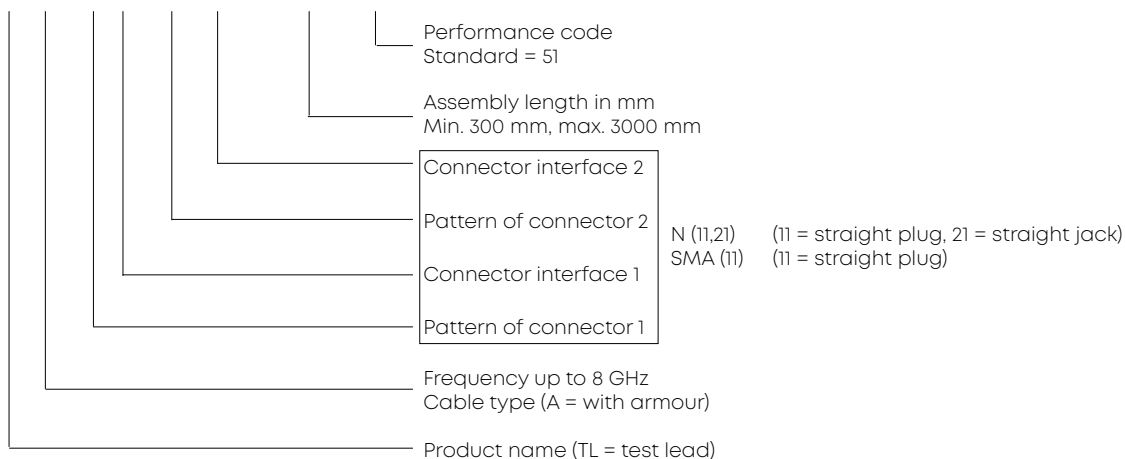

TL-P

High flexible test lead for passive intermodulation (PIM) and return loss for frequency up to 4 GHz

Product description

HUBER+SUHNER TL-P assemblies are designed for indoor and outdoor applications where passive intermodulation (PIM) has to be tested.

This assembly family is based on a flexible cable which is optimised up to 4 GHz and protected with a steel armouring. The robust design is completed with a molded protection between connector and cable.

Product features

- Impedance 50 Ω
- Applicable up to 4 GHz
- Excellent PIM performance (≤ -160 dBc)
- High mechanical endurance
- Return Loss performance
- High mating cycle (> 2000)
- Highly flexible, rugged and reliable design
- Easy to handle for work in field
- Excellent performance to price ratio



Recommended connectors

TL-P	7/16, N, 4.3-10 (screw version)
	Other connectors available on request.

Construction

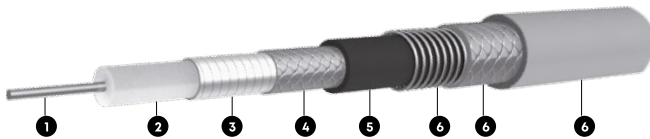

Cable	Inner conductor ①	Dielectric ②	Outer conductor ③ ④	Jacket ⑤	Ruggedisation ⑥	Outer diameter mm
TL-P	CuAg wire	PTFE	CuAg braid	FEP	stainless steel/PUR, blue	10.3

Technical data

Cable	Operating frequency	Velocity of propagation	Weight	Preferred bending radius	Temperature range
	GHz	%	g / m	mm	°C
TL-P	4	71	150.0	110.0	-15 to +65

Available connectors

Connector	Series, pattern	Code	Operating frequency GHz
7/16	straight cable plug	7/16	4
N	straight cable plug	N	4
4.3-10 (screwed)	straight cable plug	431X	4

TL-P - ... -51

Technical data

Return loss	Min. 19 dB up to 4 GHz
Passive intermodulation (tested according IEC62037-2)	Min. 160 dBc (117 dBm), 2 x 20W, @ 1.8 GHz
C.W. power (40 °C, sea level)	Min. 280 W up to 4 GHz
Attenuation	Typ. 0.75 dB/m at 2 GHz, 0.9 dB/m at 3 GHz
Shielding effectiveness	Min 120 dB
Waterproof	IP 67
Temperature range	-15 °C to +65°C
Durability (matings)	> 2'000 cycles
Bending radius repeated	Min. 50 mm (15x)
Bending radius dynamic	Min. 110 mm, flex life 10'000 bendings +/- 90°

Standard assemblies

HUBER+SUHNER cable type	Item no.	Assembly length (mm)	Min. PIM (dBc) 1.8 GHz	Min. Return loss up to 4 GHz (dB)	Max. insertion loss up to 4 GHz (dB)
TL-P-11431X-11431X-03000-51	85068157	3'000	-160	19	3.05
TL-P-11431X-11716-01500-51	85029279	1'500			1.58
TL-P-11431X-11716-03000-51	85029280	3'000			3.05
TL-P-11716-11716-01500-51	85027448	1'500			1.58
TL-P-11716-11716-03000-51	85027254	3'000			3.05
TL-P-11716-11N-01500-51	85027450	1'500			1.58
TL-P-11716-11N-03000-51	85027453	3'000			3.05

Other lengths on request with minimum order quantity of 20 pcs.

TL - P - 11 431X - 11 716 - 01500 - 51

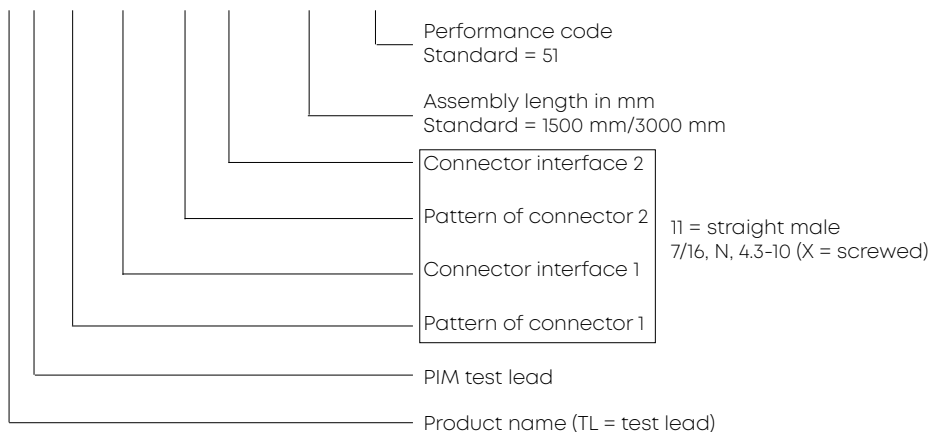

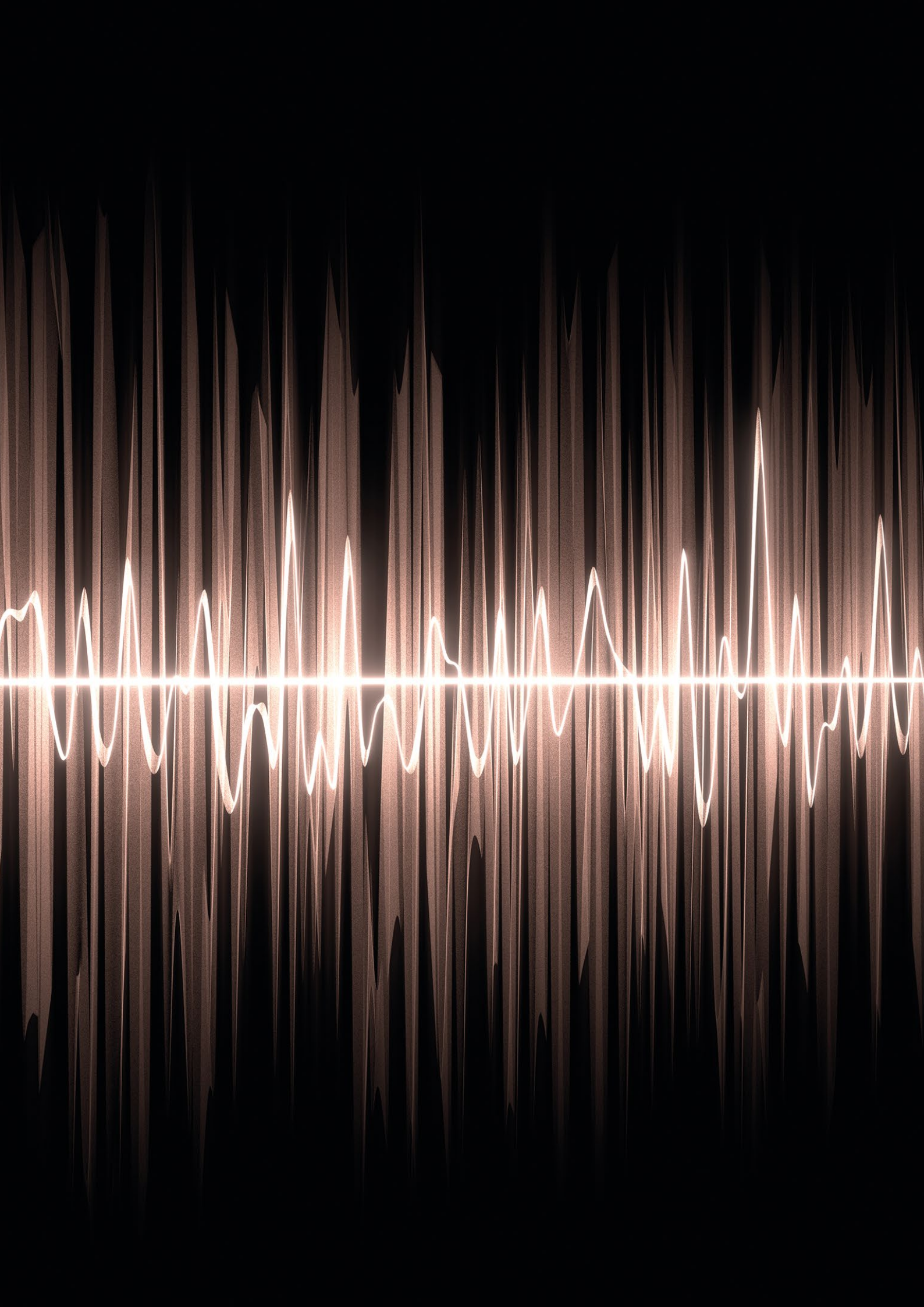

Flexible assemblies



Flexible microwave cable assemblies

HUBER+SUHNER develops and produces coaxial cables for a wide range of applications all over the world according to international standards. Many years of experience and in-house manufacturing combine to produce a portfolio of components adapted perfectly to one another. Continuous further development ensures that the products are perfectly aligned with market requirements and incorporate the latest technology. An innovative development department with in-house test laboratories can react quickly to changing market trends and even develop customer-specific solutions.

High flexible microwave cable assemblies

Multiflex 86/141

The flexible alternative to semi-rigid

- Frequency range up to 67 GHz
- High screening
- High flexibility
- Resistant to chemicals, oils, lubricants, humidity



S-series

The economical, low loss microwave cables/cable assemblies

- Frequency range up to 18 GHz
- Low insertion loss
- Excellent screening effectiveness
- Low smoke, halogen free version available



Multiflex 53-02

The highly flexible microwave coaxial cable assemblies

- Frequency range up to 100 GHz
- Thin and ultra-stable
- 50 000 flex cycles



High power microwave cable assemblies

Boa-flex II

The high power, low loss microwave coaxial cables/cable assemblies

- Frequency range up to 14 GHz
- Low density PTFE
- Exceptional phase stability
- Excellent phase versus temperature characteristics



Field terminated microwave cable assemblies

Eacon

The field terminated microwave cables/cable assemblies

- Frequency range up to 18 GHz
- Waterproof IP67
- Extremely reliable
- Easy assembling – only two connector parts



Multiflex 86/141

The flexible alternative to semi-rigid

Product description

Multiflex microwave cables are the flexible alternative to semi-rigid cables. They are used in commercial and military RF and microwave airborne systems, communication systems, cellular base stations, satellite, ground systems – in brief: anywhere a «flexible semi-rigid cable» is required.

Product features

- Impedance 50 Ω
- Applicable up to 67 GHz
- Comparable electrical performance as corresponding semi-rigid cable types, high screening
- High flexibility: no 3D drawings required for design and manufacture
- Semi-rigid connectors can be used; quick and easy assembly
- Resistant to chemicals, oils, lubricants, humidity, etc.



Recommended connectors

MULTIFLEX_86 MULTIFLEX_86_HE	MCX, MMBX, MMCX, MMPX, SMA, PC3.5, SK, PCI.85, BMA, QMA
MULTIFLEX_141	SMA, PC3.5, BMA, QMA, BNC, TNC, N
	Other connectors available on request.

Construction

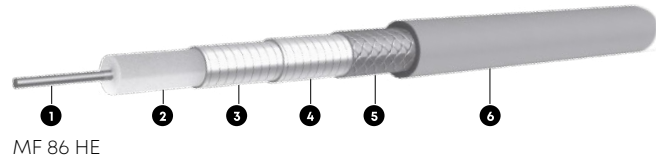
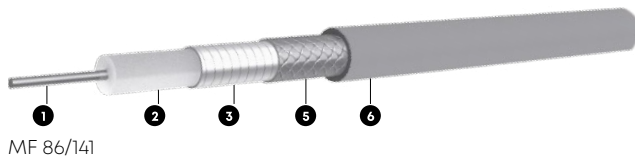

Cable	Inner conductor ①	Dielectric ②	Outer conductor ③ ④ ⑤	Jacket ⑥	Outer diameter	Screening effectiveness (up to 18 GHz)
					mm	dB
MULTIFLEX_86	CuAg Wire	PTFE	CuAg tape CuSn braid	FEP, blue	2.7	> 90
MULTIFLEX_86_HE	CuAg Wire	PTFE	CuAg double tape CuAg braid	FEP, blue	2.7	> 90
MULTIFLEX_141	CuAg Wire	PTFE	CuAg tape CuSn braid	FEP, blue	4.2	> 90

Other MULTIFLEX cables on request.

Technical data

Cable	Item no.	Max. operating frequency	Velocity of propagation	Weight g/m	Min. bending radius		Temperature range °C
		GHz	%		static mm	repeated mm	
MULTIFLEX_86	22511965	40	71	21	6	20	-65 to +165
MULTIFLEX_86_HE	84129072	67	71	21	6	20	-65 to +165
MULTIFLEX_141	22511964	33	71	45	10	40	-65 to +165

Multiflex 86/141

Attenuation (nominal values at +25 °C ambient temperature)

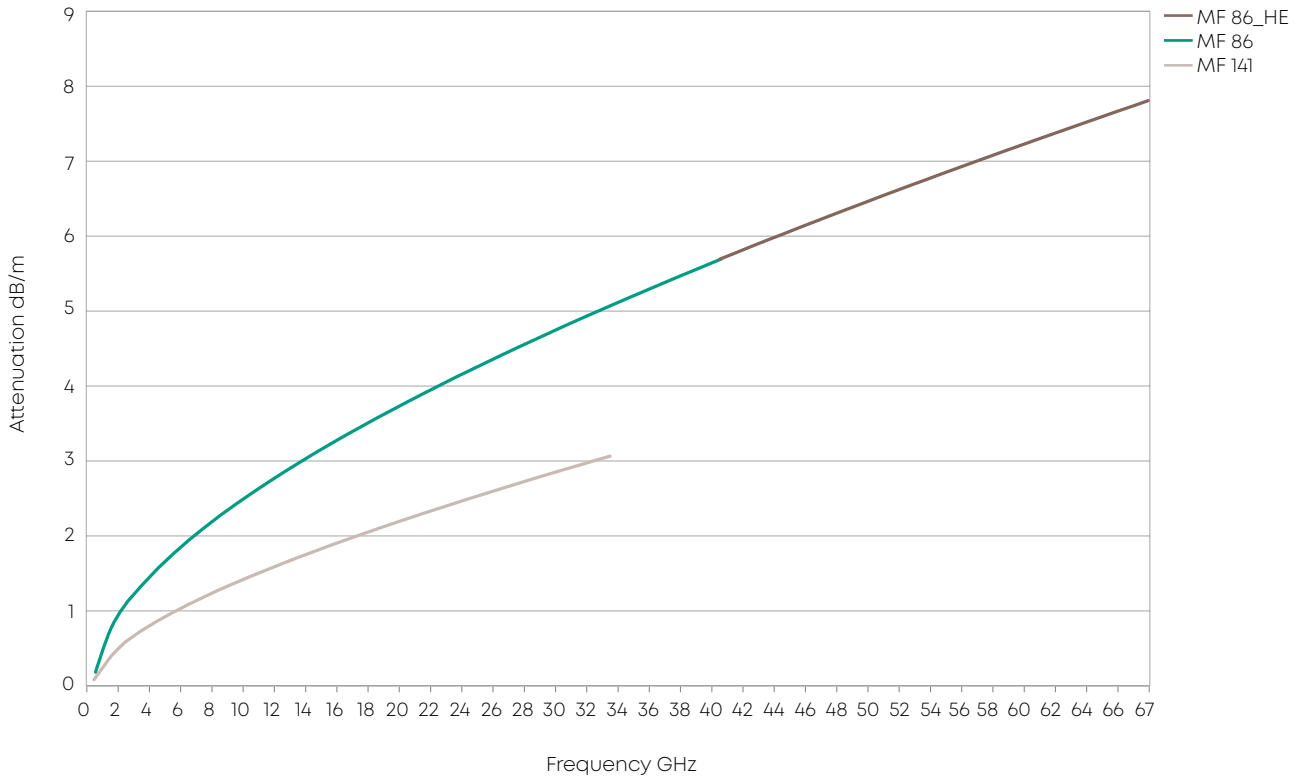

Power handling (maximum values at 25 °C ambient temperature and sea level)

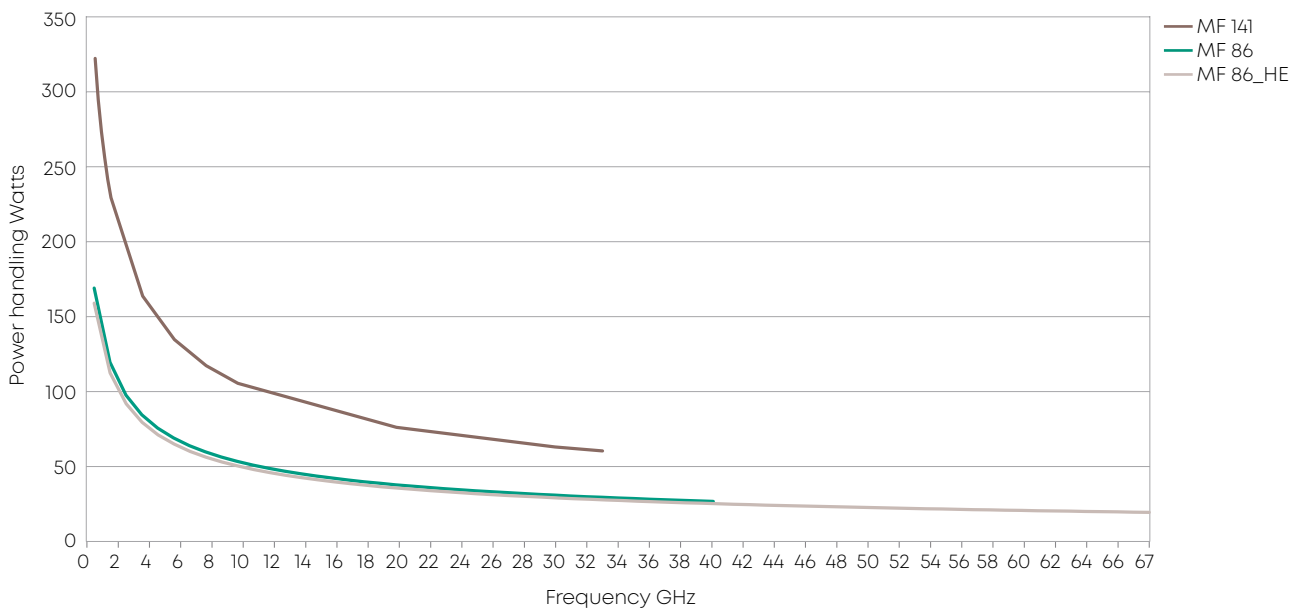

Multiflex 86/141

Available connectors

Connector	Series, pattern	HUBER+SUHNER type	Cable	Operating frequency GHz	Item no.
MCX	straight cable plug	11_MCX-50-2-19/111_NE	MULTIFLEX_86	6	23024699
	right angle cable plug	16_MCX-50-2-104/111_NH-1	MULTIFLEX_86_HE	6	23032067
	straight panel bulkhead cable jack	24_MCX-50-2-3/111_NE		6	22543580
MMBX	straight cable plug	11_MMBX-50-2-4/111_NE	MULTIFLEX_86	12.4	84026769
	right angle cable plug	16_MMBX-50-2-4/111_NE	MULTIFLEX_86_HE	12.4	84026740
	straight panel bulkhead cable jack	24_MMBX-50-2-2/111_NH		12.4	23037876
MMCX	straight cable plug	11_MMCX-50-2-1/111_OE	MULTIFLEX_86	6	22645297
	right angle cable plug	16_MMCX-50-2-13/111_OE	MULTIFLEX_86_HE	6	84032569
	straight cable jack	21_MMCX-50-2-1/111_OE		6	22645290
	straight panel bulkhead cable jack	24_MMCX-50-2-1/111_OE		6	22645954
MMPX	straight cable plug	11_MMPX-50-2-3/111_NE	MULTIFLEX_86_HE	67	84089228
	right angle cable plug	16_MMPX-50-2-2/111_NE		67	84067778
N	straight cable plug	11_N-50-2-15/113_UE	MULTIFLEX_86	18	22660315
	right angle cable plug	16_N-50-2-9/13-_UH	MULTIFLEX_86_HE	11	23013729
PC 1.85	straight cable plug	11_PC185-50-2-4/19-_NE	MULTIFLEX_86_HE	67	84144282
	straight cable jack	21_PC185-50-2-4/19-_NE		67	84144175
PC 3.5	straight cable plug	11_PC35-50-2-5/199_UE	MULTIFLEX_86_HE	26.5	84139219
	straight cable jack	21_PC35-50-2-5/199_UE		26.5	84139085
	straight panel bulkhead cable jack	24_PC35-50-2-5/199_UE		26.5	84139301
QMA	straight cable plug	11_QMA-50-2-3/133_NE	MULTIFLEX_86	18	23017704
	right angle cable plug	16_QMA-50-2-3/133_NE	MULTIFLEX_86_HE	11	23017666
	straight panel bulkhead cable jack	24_QMA-50-2-1/111_NE		18	23017742
SK	straight cable plug	11_SK-50-2-60/199_NE	MULTIFLEX_86_HE	40	84098644
	straight cable jack	21_SK-50-2-61/199_NE		40	84094378
SMA	straight cable plug	11_SMA-50-2-65/119_NE	MULTIFLEX_86	18	22642315
	right angle cable plug	16_SMA-50-2-43/133_NE	MULTIFLEX_86_HE	18	22641953
	straight cable jack	21_SMA-50-2-15/111_NE		18	22544549
	straight panel bulkhead cable jack	24_SMA-50-2-15/111_NE		18	22544532
SMB	straight cable plug	11_SMB-50-2-13/111_NE	MULTIFLEX_86	4	22543362
	right angle cable plug	16_SMB-50-2-23/111_NE	MULTIFLEX_86_HE	4	22644079
	straight panel bulkhead cable jack	24_SMB-50-2-13/111_NE		4	22640822

Multiflex 86/141

Connector	Series, pattern	HUBER+SUHNER type	Cable	Operating frequency GHz	Item no.
SMC	straight cable plug	11_SMC-50-2-13/111_NH	MULTIFLEX_86 MULTIFLEX_86_HE	10	22650675
	right angle cable plug	16_SMC-50-2-25/111_NE		10	22644126
	straight panel bulkhead cable jack	24_SMC-50-2-13/111_NE		10	22640297
TNC	straight cable plug	11_TNC-50-2-20/103_NE	MULTIFLEX_86 MULTIFLEX_86_HE	11	22642519
	straight panel bulkhead cable jack	24_TNC-50-2-31/133_NE		11	23001721
N	straight cable plug	11_N-50-3-13/113_NE	MULTIFLEX_141	18	22542083
	straight cable plug	11_N-50-3-51/133_NE		18	22543919
	right angle cable plug	16_N-50-3-15/133_NE		11	22648832
	straight cable jack	21_N-50-3-11/133_NE		18	22543921
	straight panel bulkhead cable jack	24_N-50-3-14/133_NE		18	22542300
	straight panel bulkhead cable jack	24_N-50-3-51/19-_NE		18	22642344
	straight panel cable jack, flange mount	25_N-50-3-9/133_NE		11	22543952
PC3.5	straight cable plug	11_PC35-50-3-4/199_UE	MULTIFLEX_141	26.5	84009380
	straight cable jack	21_PC35-50-3-3/199_UE		26.5	84009382
	straight panel bulkhead cable jack	24_PC35-50-3-2/199_UE		26.5	84009383
QMA	straight cable plug	11_QMA-50-3-3/133_NE	MULTIFLEX_141	18	23017695
	right angle cable plug	16_QMA-50-3-3/133_NE		6	23017693
	straight panel bulkhead cable jack	24_QMA-50-3-3/111_NE		18	23017683
QN	straight cable plug	11_QN-50-3-3/113_NE	MULTIFLEX_141	11	23033393
	right angle cable plug	16_QN-50-3-3/13-_NE		11	23033268
	straight panel bulkhead cable jack	24_QN-50-3-3/13-_NE		11	23033423
SMA	straight cable plug	11_SMA-50-3-15/111_NE	MULTIFLEX_141	18	22544547
	straight cable plug	11_SMA-50-3-235/133_NE		18	84130698
	right angle cable plug	16_SMA-50-3-3/111_NE		18	22640073
	straight cable jack	21_SMA-50-3-15/111_NE		18	22544550
	straight panel bulkhead cable jack	24_SMA-50-3-15/111_NE		18	22641153
TNC	straight cable plug	11_TNC-50-3-29/103_NE	MULTIFLEX_141	11	22641997
	straight panel bulkhead cable jack	24_TNC-50-3-30/133_NH		11	23001723

S-series

The economical, low loss microwave cable

Product description

The S-series is a line of cost-efficient, low loss microwave cables. It covers technically demanding requirements in a wide range of applications, preferably in fixed installations. These versatile cables are characterised by their very low insertion loss across a wide frequency range. S-series cables are easy to assemble and are made of environmentally friendly, halogen free materials.

Product features

- Impedance 50 Ω
- Applicable up to 18 GHz
- Low insertion loss
- Excellent screening effectiveness
- Quick and easy to assemble
- Low smoke, free of halogen free version available
- Cost-efficient, environmentally friendly solution for a wide range of applications



Recommended connectors

S_04272_B	SMA, TNC, N
S_04262_B-01	SMA, TNC, N
	Other connectors available on request.

Construction

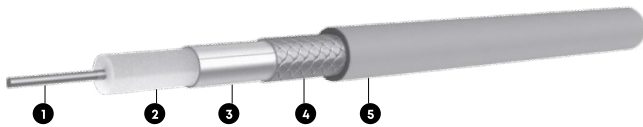

Cable	Inner conductor ①	Dielectric ②	Outer conductor ③④	Jacket ⑤	Outer diameter	Screening effectiveness up to 18 GHz
					mm	dB
S_04272_B	CuAg Wire	SPE	Al tape/CuSn braid	PE, blue	5.5	> 90
S_04262_B-01	CuAg Wire	SPE	Al tape/CuSn braid	LSFH, black	5.5	> 90
S_04212_B	CuAg Wire	SPE	Al tape/CuSn braid	PUR, black	5.5	> 90

Technical data

Cable	Item no.	Max. operating frequency	Velocity of propagation	Weight	Min. bending radius		Temperature range
					GHz	%	
S_04272_B	22511622	18	82	44	25	90	-40 to +85
S_04262_B-01	84000918	18	82	41	25	90	
S_04212_B	22511855	18	82	41	25	90	

S-series

Attenuation (nominal values at +25 °C ambient temperature)

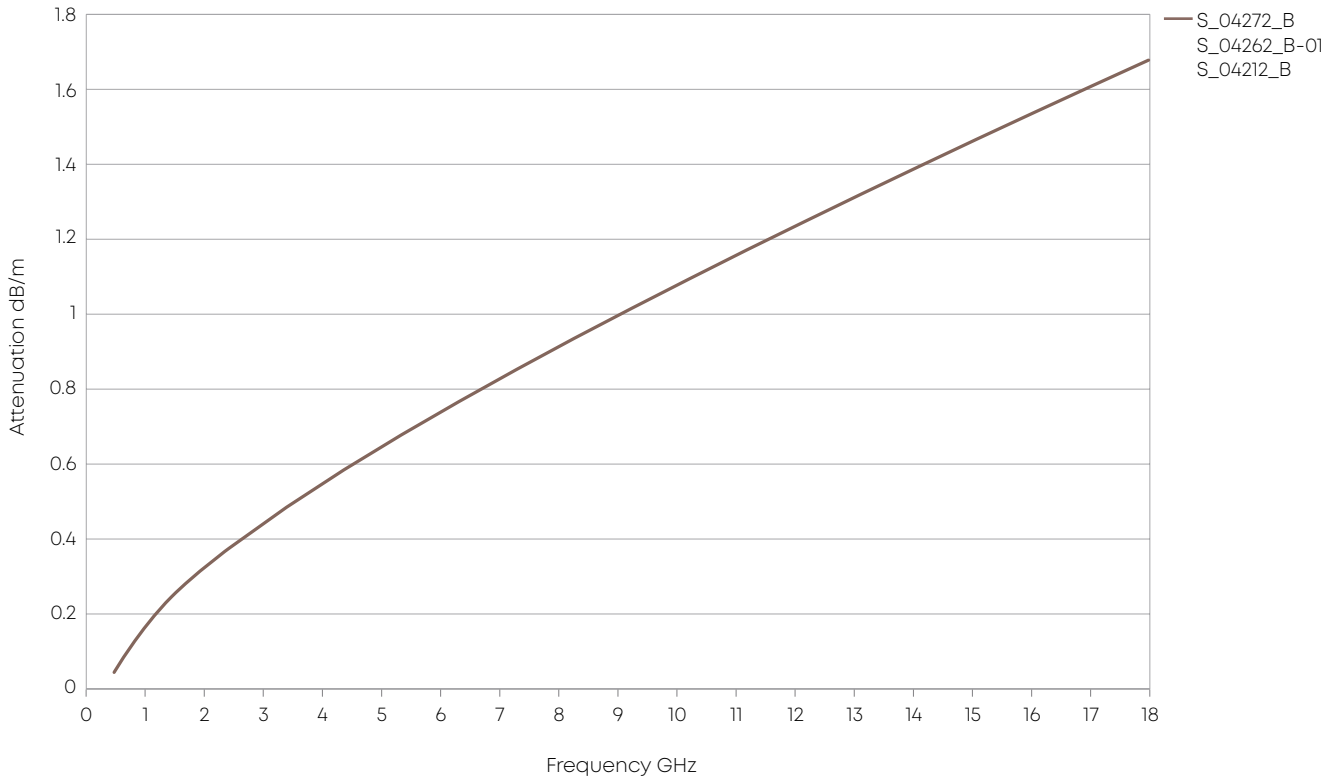

Power handling (maximum values at 25 °C ambient temperature and sea level)

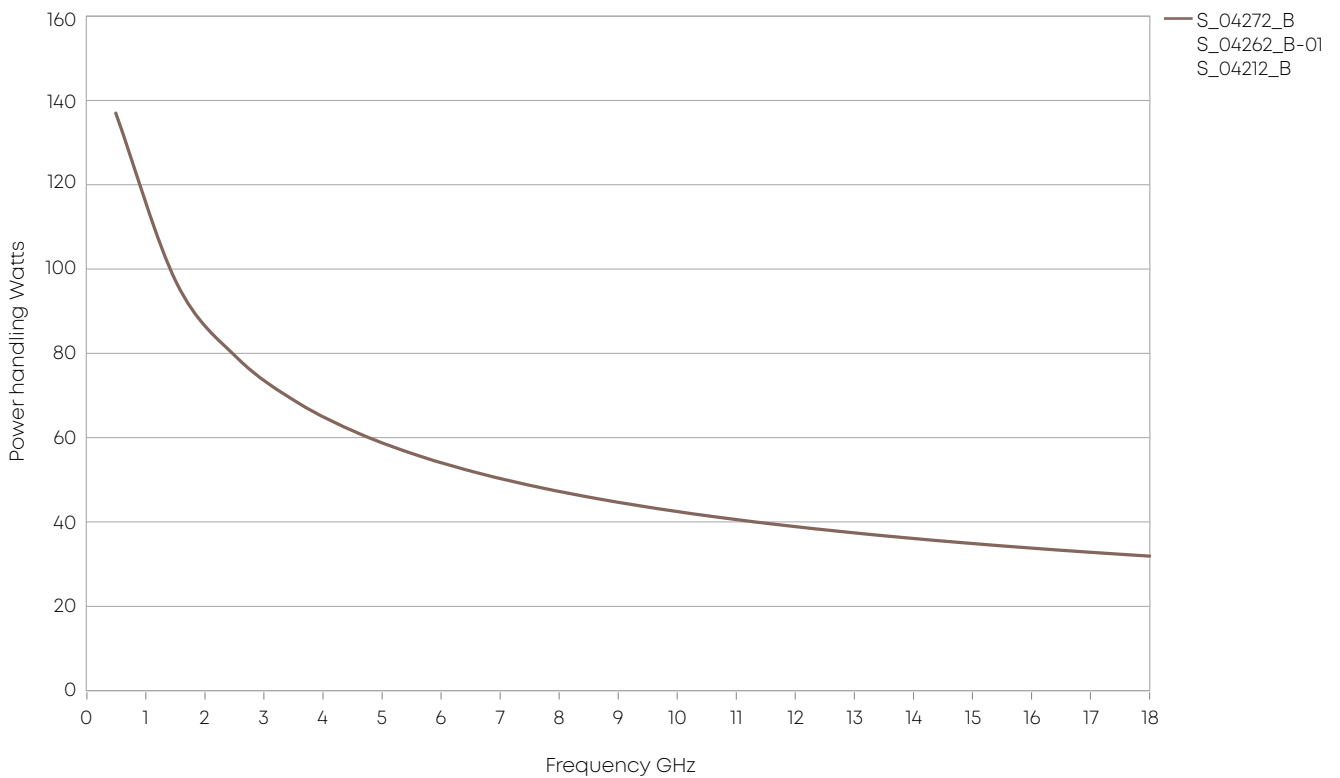

S-series

Available connectors

Connector	Series, pattern	HUBER+SUHNER type	Cable	Operating frequency	Item no.
				GHz	
N	straight cable plug	11_N-50-4-10/133_NH	S_04272_B, S_04262_B-01 S_04212_B	11	84026255
	straight cable plug	11_N-50-4-55/133_NE		18	22645935
	right angle cable plug	16_N-50-4-53/199_NE		18	22645021
	straight panel bulkhead cable jack	24_N-50-4-53/133_NE		18	22644946
SMA	straight cable plug	11_SMA-50-4-4-53/139_NE	S_04272_B, S_04262_B-01 S_04212_B	18	22644342
	right angle cable plug	16_SMA-50-4-50/133_NE		18	84130714
	straight cable jack	21_SMA-50-4-52/133_NE		18	22644409
TNC	straight cable plug	11_TNC-50-4-52/133_NE	S_04272_B, S_04262_B-01 S_04212_B	11	22644434
	straight panel bulkhead cable jack	24_TNC-50-4-52/133_NE		11	22644938

Multiflex 53-02

The highly flexible microwave cable

Product description

The thin, highly flexible and ultra-stable microwave cable for utmost demands.

Product features

- Impedance 50 Ω
- Applicable up to 100 GHz
- 50 000 flex cycles



Recommended connectors

MULTIFLEX_53-02	SMA, SK, PC2.4, PC1.85, PC1.0, MMPX
	Other connectors available on request

Construction

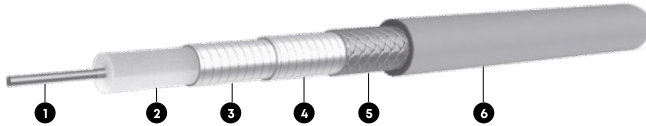

Cable	Inner conductor 1	Dielectric 2	Outer conductor 3 4 5	Jacket 6	Outer diameter mm	Screening effectiveness (up to 18 GHz) dB
MULTIFLEX_53-02	CuAg Wire	PTFE	double CuAg tape/ braid	FEP, blue	1.74	> 90

Technical data

Cable	Item no.	Max. operating frequency	Velocity of propagation	Weight g/m	Min. bending radii		Temperature range °C
		GHz	%		static mm	repeated mm	
MULTIFLEX_53-02	85006318	100	70	10	≥1.5	≥10	-55 to + 165

Available connectors

Connector	Series, pattern	HUBER+SUHNER type	Cable	Operating frequency GHz	Item no.
SMA	straight cable jack	21_SMA-50-1-5/111_NH	MULTIFLEX_53-02	18	85016291
SMA	straight cable plug	11_SMA-50-1-14/111_NH		18	84134500
SK	straight cable plug	11_SK-U50-1-5/119_NH		40	84087678
SK	straight cable jack	21_SK-U50-1-4/111_NH		40	85153736
PC2.4	straight cable plug	11_PC24-U50-1-1/119_NH		50	85028108
PC2.4	straight cable jack	21_PC24-U50-1-2/111_NH		50	85157681
MMPX	straight cable plug	11_MMPX-50-1-4/111_NE		67	84122130
PC1.85	straight cable plug	11_PC185-50-1-7/19-_NE		67	85085315
PC1.85	straight cable jack	21_PC185-50-1-7/19-_NH		67	85093389
PC1	straight cable plug	11_PC1-50-1-4/113_UI		100	85167170

Multiflex 53-02

Attenuation (nominal values at +25 °C ambient temperature)

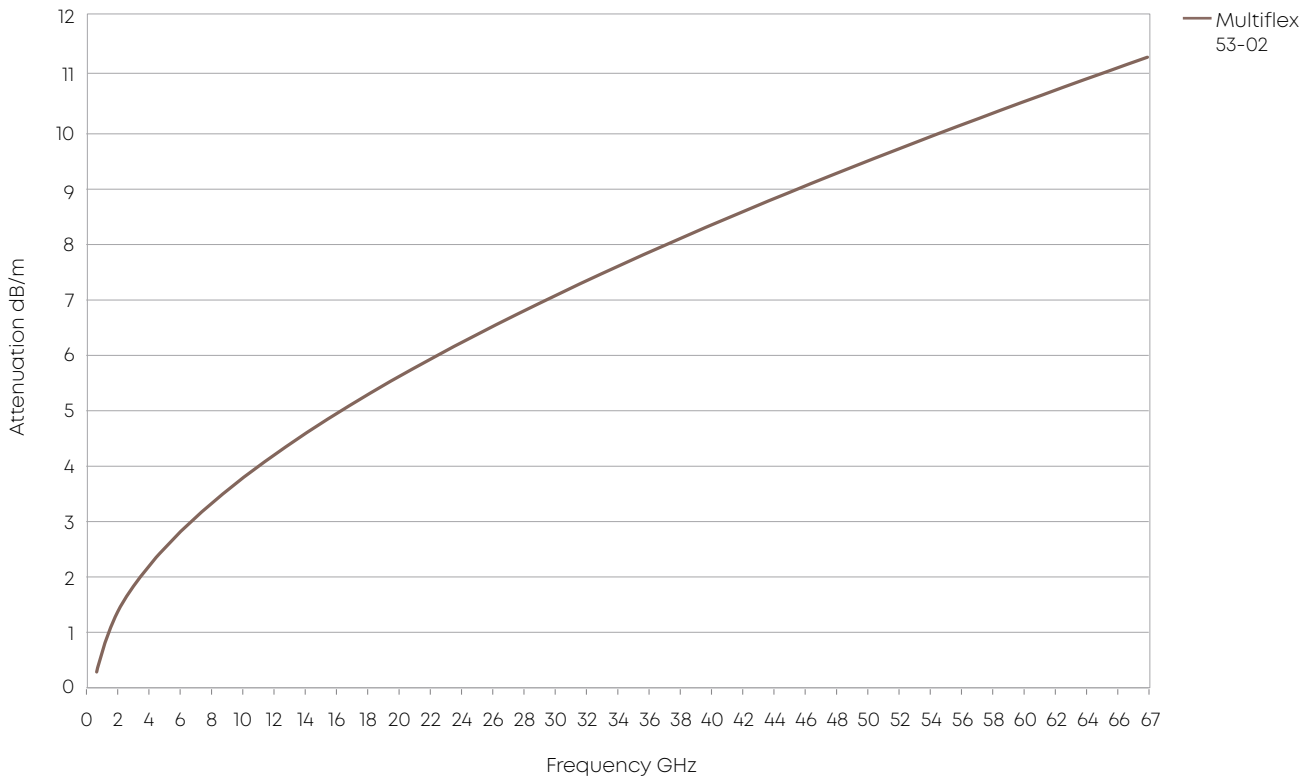

Power handling (maximum values at 25 °C ambient temperature and sea level)

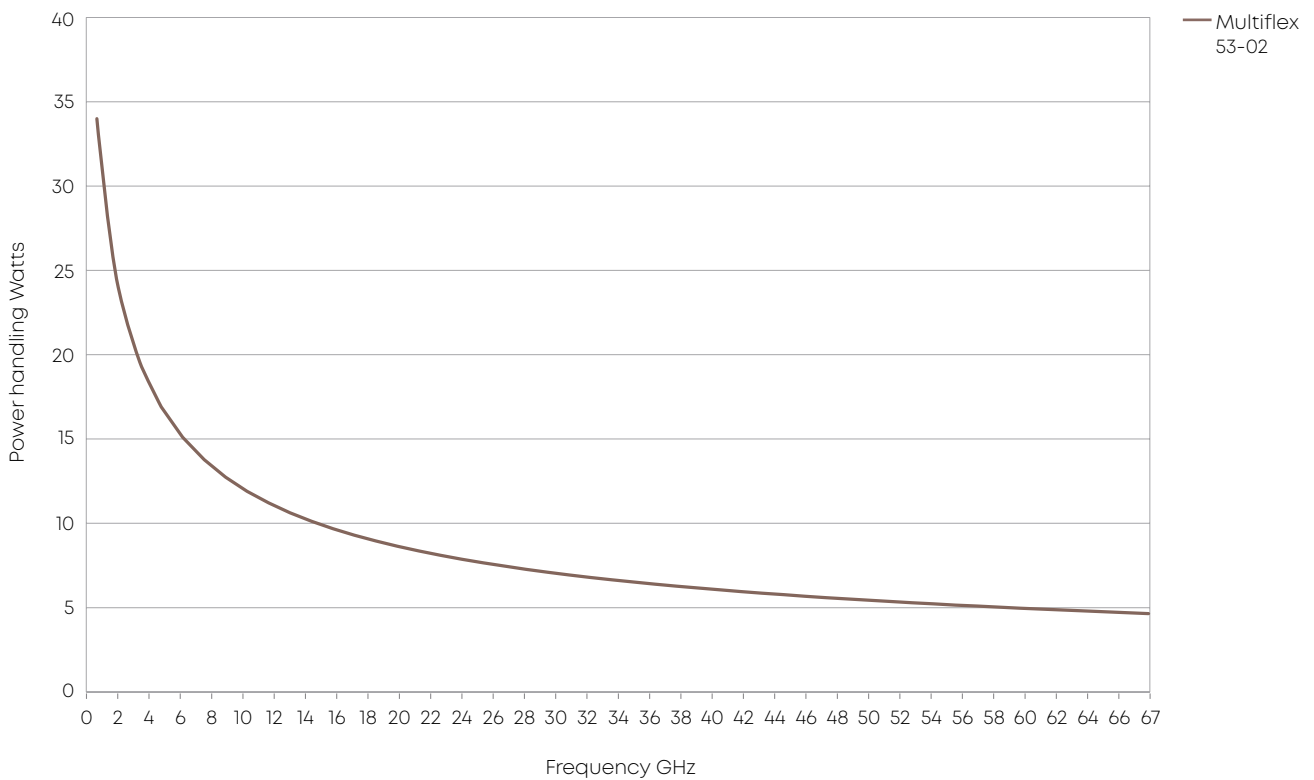

Boa-flex II

The high power, low loss microwave coaxial cable assemblies

Product description

Boa-flex II cables utilise a microporous PTFE dielectric for low loss with minimal phase change due to temperature changes and flexure. Typical velocity is 77 % of the speed of light. All offer very low loss and are extremely stable with flexure.

Product features

- Impedance 50 Ω
- Applicable up to 14 GHz
- Low density PTFE for superior electrical performance
- Helical wrapped outer conductor for increased electrical performance
- Exceptional phase and IL stability with flexure
- Excellent phase versus temperature characteristics
- Preferred for phase matching and tracking applications



Recommended connectors

32071	TNC, N, SC
	Others available

Construction

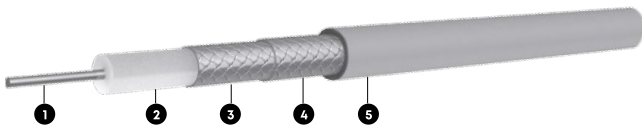

Cable	Inner conductor ①	Dielectric ②	Outer conductor ③	Outer braid ④	Outer braided shield ⑤	Outer diameter mm
32071	CuAg strand	PTFE microporous	CuAg tape	CuAg	FEP, translucent amber	9.5

Technical data

Cable	Item no.	Max. operating frequency	Velocity of propagation	Weight g/m	Min. bending radius		Temperature range °C
		GHz	%		static mm	repeated mm	
32071	80310956	14	77.8	208.3	50.8	101.6	-55 to +200

Available connectors

Connector	Series, pattern	HUBER+SUHNER type	Cable	Operating frequency GHz	Item no.
TNC	straight cable plug	29614-32-71	32071	10	80318585
N	straight cable plug	29602-32-71		12.4	80318491
	straight cable jack	29601-32-71		12.4	80318466
	straight bulkhead cable jack	29636-32-71		12.4	80340623
SC	straight cable plug	29608-32-71		10	80318547

Boa-flex II

Attenuation (nominal values at +25 °C ambient temperature)

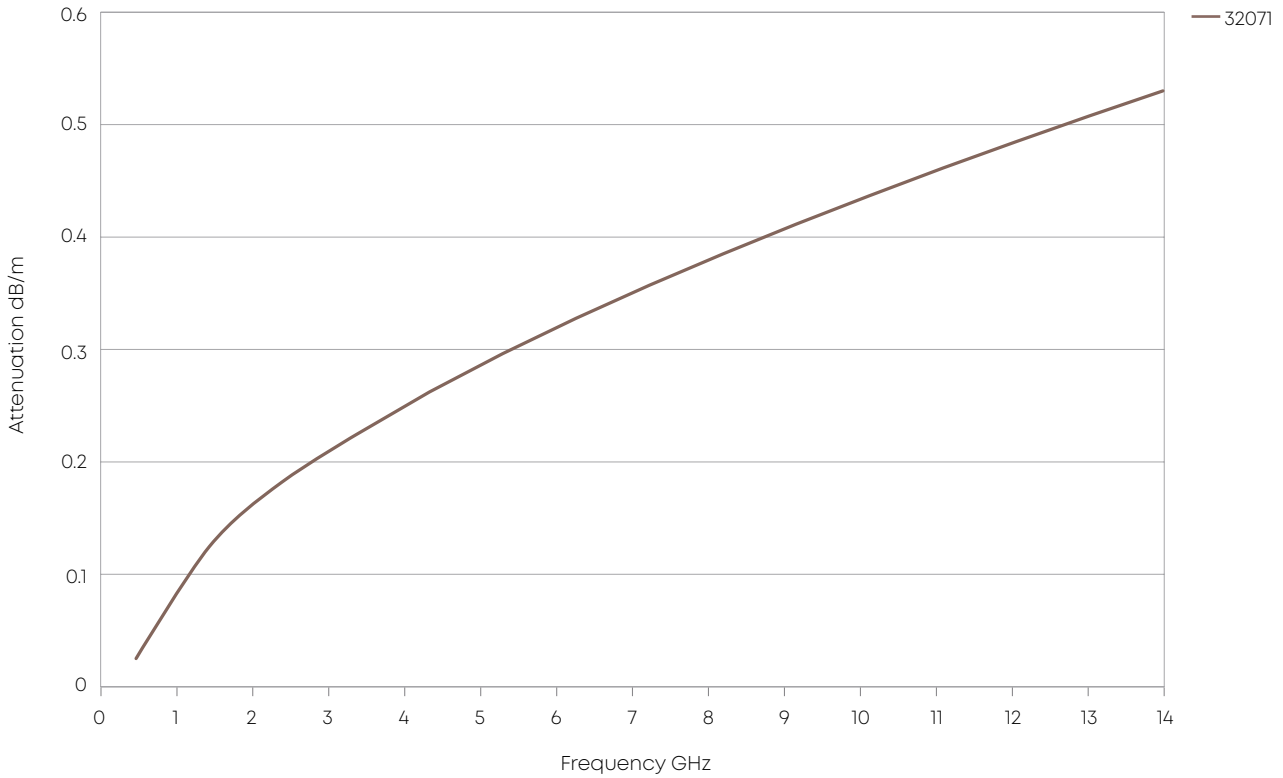

Power handling (maximum values at 25 °C ambient temperature and sea level)

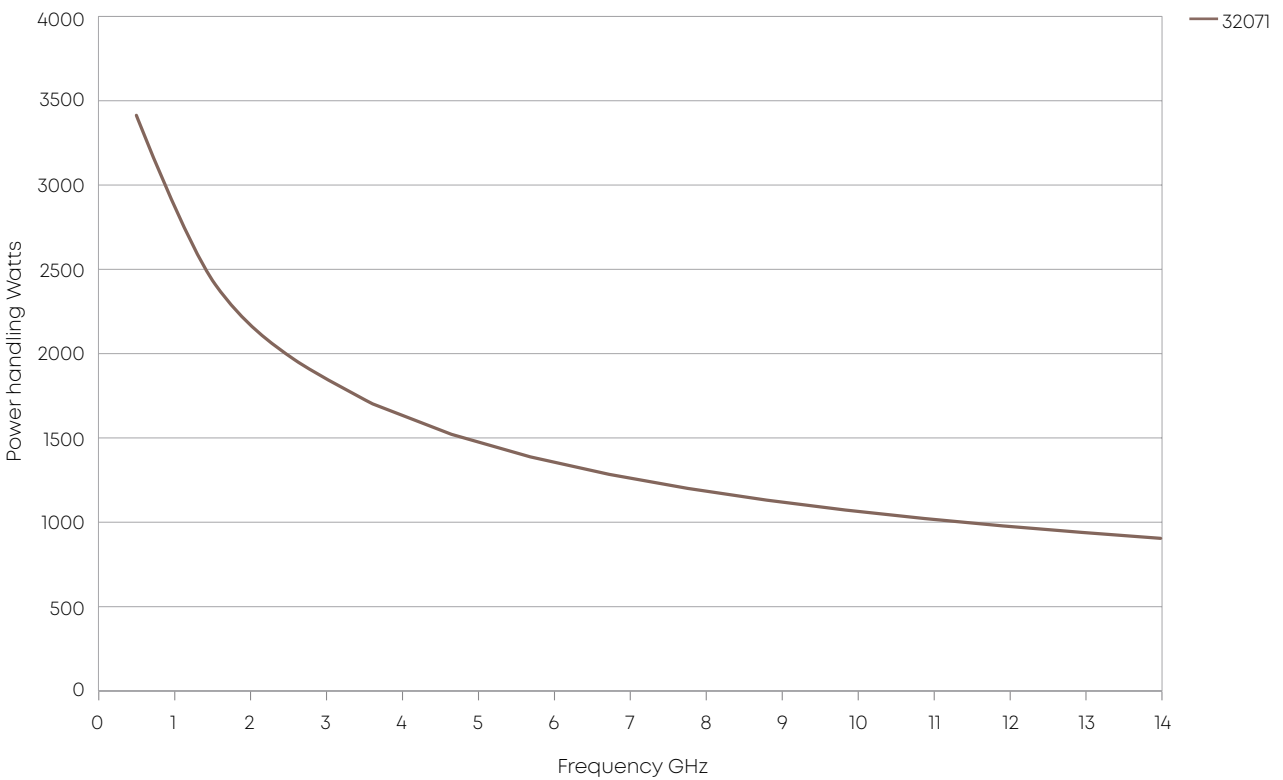

Boa-flex II

Available Connectors

		Boaflex II
TNC	Straight Male	29614-32-71
N	Straight Male	29080HTPV-32-71

Eacon

The field terminated microwave assembly

Product description

To suit to the needs of our customers, HUBER+SUHNER has developed this innovative solution. Eacon stands for a simple, flexible and fast way to assemble microwave cable and connectors in the field without compromises to the best performance. The new field terminated microwave cable and connectors are light and waterproofed, built for frequencies up to 18 GHz – ready for use in the defense market as well as generally in the industrial market.

Product features

- Impedance 50 Ω
- Applicable up to 18 GHz
- Velocity of propagation 77%
- Field terminated
- Waterproof IP 67
- Low loss
- Extremely reliable
- Assembling tool kits available
- Easy assembling – only two connector parts
- Taking on site decision regarding length and configurations
- Narrowest cable feedthrough dimensions (assembling after installation)
- More added value for customers



Recommended connectors

Eacon_2C	SMA
Eacon_4C	BNC, N, QMA, SMA, TNC
Eacon_6C	TNC, N
Other connectors available on request.	

Construction

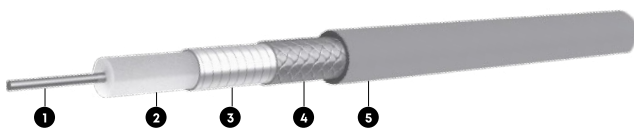

Cable	Item no.	Inner conductor ①	Dielectric ②	Outer conductor ③④	Jacket ⑤	Outer Diameter mm
Eacon_2C	84116378	CuAg Wire	LD-PTFE	CuAg tape / StCuAg braid	FEP, white	3.75
Eacon_4C	84048293	CuAg Wire	LD-PTFE	CuAg tape / braid	FEP, white	5.50
Eacon_6C	84116403	CuAg Wire	LD-PTFE	CuAg tape / braid	FEP, white	7.70

Assembly types

		Eacon_2C	Eacon_4C	Eacon_6C
Construction				
Max. operating frequency	GHz	18	18	18
Application		static	static	static
Velocity of propagation	%	77	77	77
Weight	g/m	39	73	148
Min. bending radius static	mm	12	16	24
Min. bending radius repeated	mm	20	25	40
Temperature range	°C	-55 to +200	-55 to +200	-55 to +200
Tensile load	N	100	180	180
Crush resistance	kN/m	8	8	8
Inner conductor		wire	wire	wire
Dielectric		LD-PTFE	LD-PTFE	LD-PTFE
Outer conductor		Tape /braid	Tape /braid	Tape /braid
Jacket		FEP	FEP	FEP
Outer diameter	mm	3.75	5.50	7.70
Screening effectiveness (up to 18 GHz)	dB	>90	>90	>90
Phase stability vs. flexure, 360°, diameter 55 mm (2C, 4C), 85 mm (6C)	°el/GHz	< 1.2	< 1.7	< 2.0
Phase stability vs. temperature (-40 to +85 °C)	ppm	<1'500	< 1'500	< 1'500
Cable attenuation at 25 °C	dB/m	See graph	See graph	See graph
Power handling	watt	See graph	See graph	See graph
Smoke index		naval engineering Standard 711 and ASTM-B 622-92 (140°F for 24 hours, conditioned @ 73°F and 50% relative humidity)	naval engineering Standard 711 and ASTM-B 622-92 (140°F for 24 hours, conditioned @ 73°F and 50% relative humidity)	naval engineering Standard 711 and ASTM-B 622-92 (140°F for 24 hours, conditioned @ 73°F and 50% relative humidity)
Solar radiation		MIL-STD-810, Method 505, Procedure II	MIL-STD-810, Method 505, Procedure II	MIL-STD-810, Method 505, Procedure II
Flammability		MIL-C-87104, Paragraph 4.6.4.8	MIL-C-87104, Paragraph 4.6.4.8	MIL-C-87104, Paragraph 4.6.4.8
Chemical resistance		British Standard 3G100, Part 2, Section 3, Class A	British Standard 3G100, Part 2, Section 3, Class A	British Standard 3G100, Part 2, Section 3, Class A
Fungus		MIL-STD-810, Method 508.3	MIL-STD-810, Method 508.3	MIL-STD-810, Method 508.3
RoHS (2002/95/EC)		compliant	compliant	compliant

Eacon

Attenuation (nominal values at +25 °C ambient temperature)

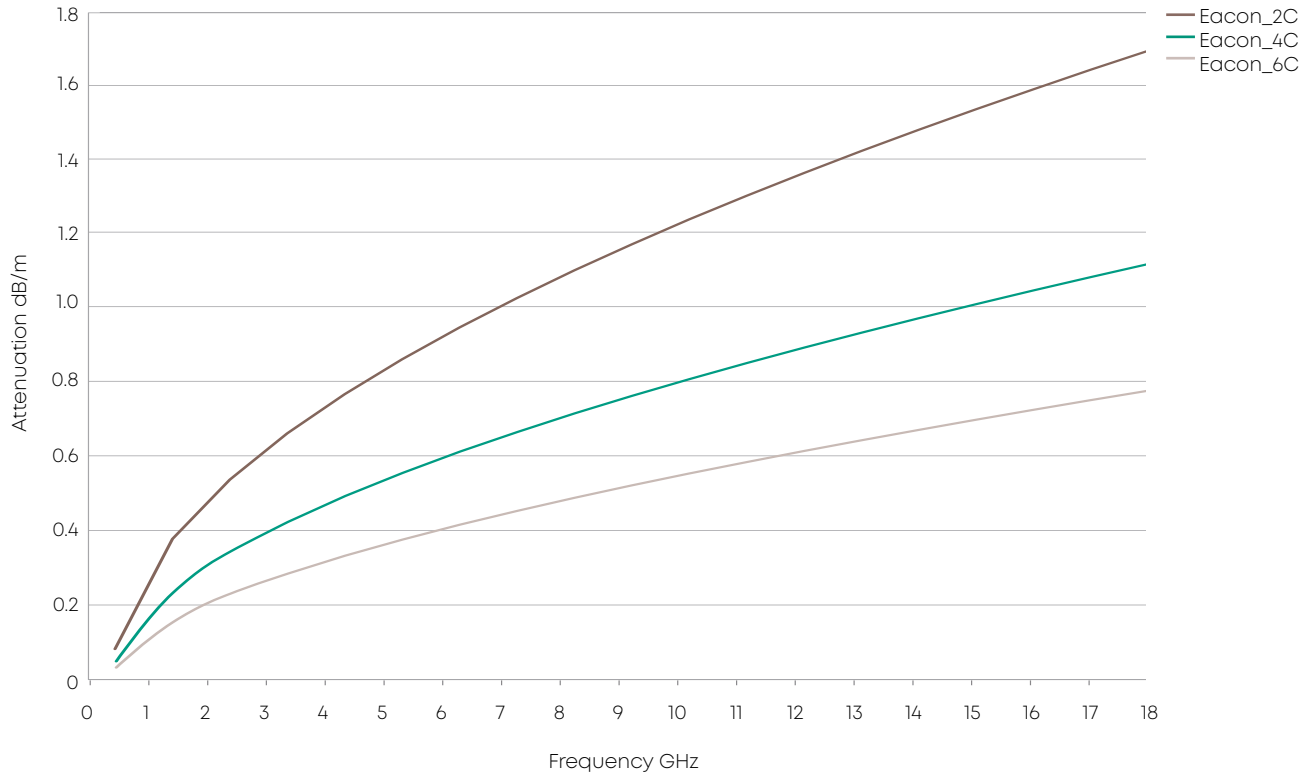

Power handling (maximum values at 25 °C ambient temperature and sea level)

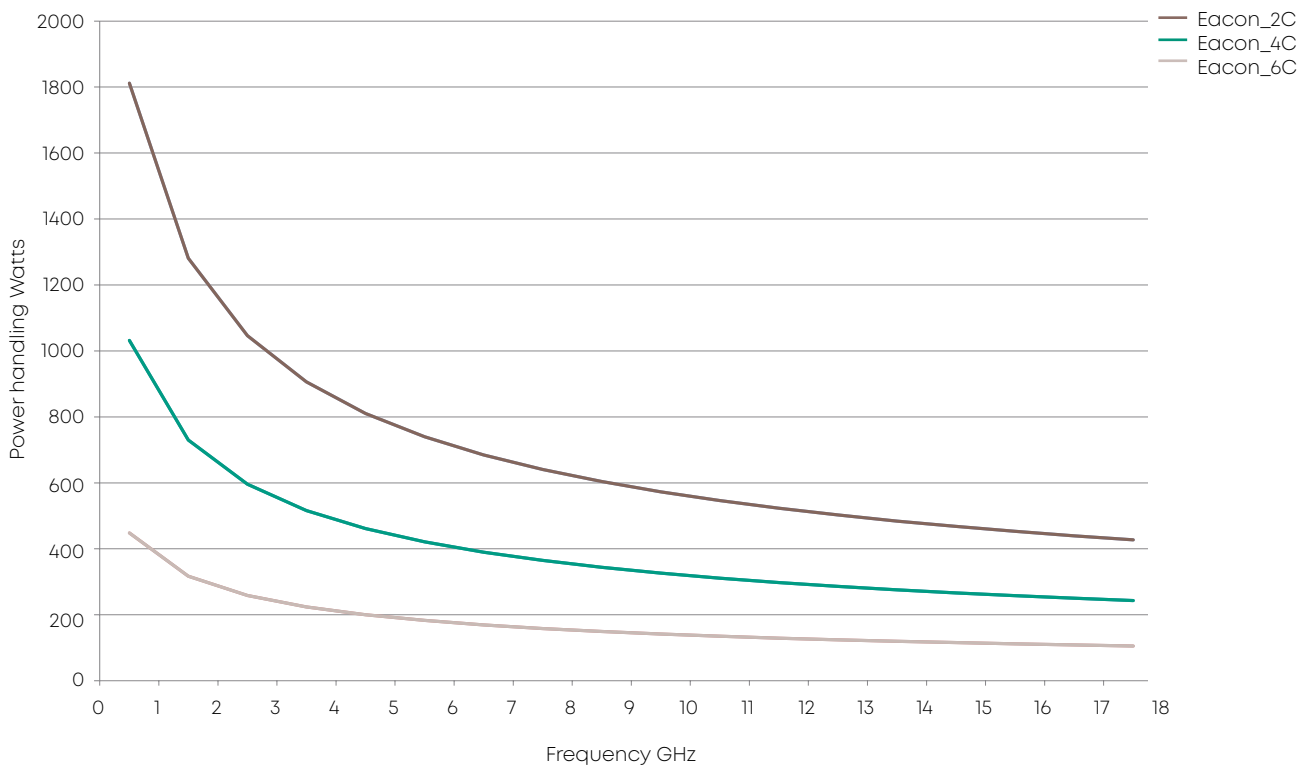

Available connectors

Connector	Series, pattern	HUBER+SUHNER type		Eacon_2C	Eacon_4C	Eacon_6C	Typical VSWR			
							4 GHz	6 GHz	11 GHz	18 GHz
BNC	Straight cable plug	11_BNC-50-4-33/12-_NE	84139633		•		1.15			
	Right angle cable plug	16_BNC-50-4-14/12-_NE	84146122		•		1.30			
N	Straight cable plug	11_N-50-4-19/12-_NE	84070286		•			1.12	1.35	1.40
	Straight cable plug	11_N-50-6-19/12-_NE	85074230			•		1.12	1.15	
	Right angle cable plug	16_N-50-4-13/12-_NE	84070287		•			1.12	1.15	1.25 *
	Right angle cable plug	16_N-50-6-14/12-_NE	85074231			•		1.12	1.25	
	Straight panel bulkhead cable jack	24_N-50-4-13/12-_NE	85005806		•			1.12		1.17
	Straight panel cable jack, flange mount	25_N-50-4-8/122_NE	84070288		•			1.12		1.17
QMA	Straight cable plug	11_QMA-W50-4-4/19-_NE	84121825		•			1.12		
SMA	Straight cable plug	11_SMA-50-2-76/199_NE	85074234	•				1.13		1.30
	Straight cable plug	11_SMA-50-4-101/199_NE	84070289		•			1.12		1.15
	Right angle cable plug	16_SMA-50-2-20/199_NE	85074235	•				1.12	1.35	
	Right angle cable plug	16_SMA-50-4-165/199_NE	84070290		•			1.12	1.45	
TNC	Straight cable plug	11_TNC-50-4-23/12-_NE	84070283		•			1.12	1.30	
	Straight cable plug	11_TNC-50-6-8/12-_NE	85074232			•		1.09	1.22	
	Right angle cable plug	16_TNC-50-4-101/12-_NE	84070284		•			1.12	1.30	
	Right angle cable plug	16_TNC-50-6-12/12-_NE	85074233			•		1.17	1.35	
	Straight panel cable jack, flange mount	25_TNC-50-4-18/12-_NE	84070285		•			1.12	1.20	

*(up to 15 GHz)

Eacon

Assembling tool kits for all connectors, used with Eacon 2C/4C/6C cables (with additional space for other auxiliary tools and spare parts).



Combined Eacon 2C / 4C / 6C assembling tool kit

HUBER + SUHNER type	Item no.	Content	Size
74_Z-0-0-647	85075222	all tools, needed to assemble Eacon 2C / 4C / 6C	395 × 315 × 100 mm/ 15.5 × 12.4 × 3.9 in

Eacon 2C assembling tool kit

HUBER + SUHNER type	Item no.	Content	Size
74_Z-0-0-645	85075220	all tools, needed to assemble Eacon 2C	395 × 315 × 100 mm/ 15.5 × 12.4 × 3.9 in

Pos.	HUBER + SUHNER type	Item no.	Description	Comment
1	74_Z-0-0-12	22642718	metal saw	-
2	74_Z-0-0-13	22644241	replacement of saw blade	please order separately (not incl. in the toolbox)
3	74_Z-0-0-475	84079191	torque wrench 8 mm (4 Nm)	please check the torque from time to time
4	74_Z-0-0-474	84078907	trim tool	-
5	74_Z-0-0-638	85075218	stripping tool Eacon 2C	-
6	74_Z-0-0-563	84079618	blades cartridge for stripping tool 74_Z-0-0-638	please order separately (not incl. in the toolbox)
7	74_Z-0-0-639	85075217	Cone	5 pcs.
8	74_Z-0-0-641	85075213	Fixation tool for cutting	

Eacon 4C assembling tool kit

HUBER + SUHNER type	Item no.	Content	Size
74_Z-0-0-606	84074447	all tools, needed to assemble Eacon 4C	395 × 315 × 100 mm/ 15.5 × 12.4 × 3.9 in

Pos.	HUBER + SUHNER type	Item no.	Description	Comment
1	74_Z-0-0-12	22642718	metal saw	-
2	74_Z-0-0-13	22644241	replacement of saw blade	please order separately (not incl. in the toolbox)
3	74_Z-0-0-475	84079191	torque wrench 8 mm (4 Nm)	please check the torque from time to time
4	74_Z-0-0-474	84078907	trim tool	-
5	74_Z-0-0-473	84079184	stripping tool Eacon 4C	-
6	74_Z-0-0-563	84079618	blades cartridge for stripping tool 74_Z-0-0-473	please order separately (not incl. in the toolbox)
7	74_Z-0-0-642	85075214	Fixation tool for cutting	

Eacon 6C assembling tool kit

HUBER + SUHNER type	Item no.	Content	Size
74_Z-0-0-646	85075221	all tools, needed to assemble Eacon 6C	395 × 315 × 100 mm/ 15.5 × 12.4 × 3.9 in

Pos.	HUBER + SUHNER type	Item no.	Description	Comment
1	74_Z-0-0-12	22642718	metal saw	-
2	74_Z-0-0-13	22644241	replacement of saw blade	please order separately (not incl. in the toolbox)
3	74_Z-0-0-480	84079190	torque wrench 12 mm (5 Nm)	please check the torque from time to time
4	74_Z-0-0-474	84078907	trim tool	-
5	74_Z-0-0-640	85075219	stripping tool Eacon 6C	-
6	74_Z-0-0-564	84079619	blades cartridge for stripping tool 74_Z-0-0-640	please order separately (not incl. in the toolbox)
	74_Z-0-0-643	85075215	Fixation tool for cutting	

Formstable assemblies

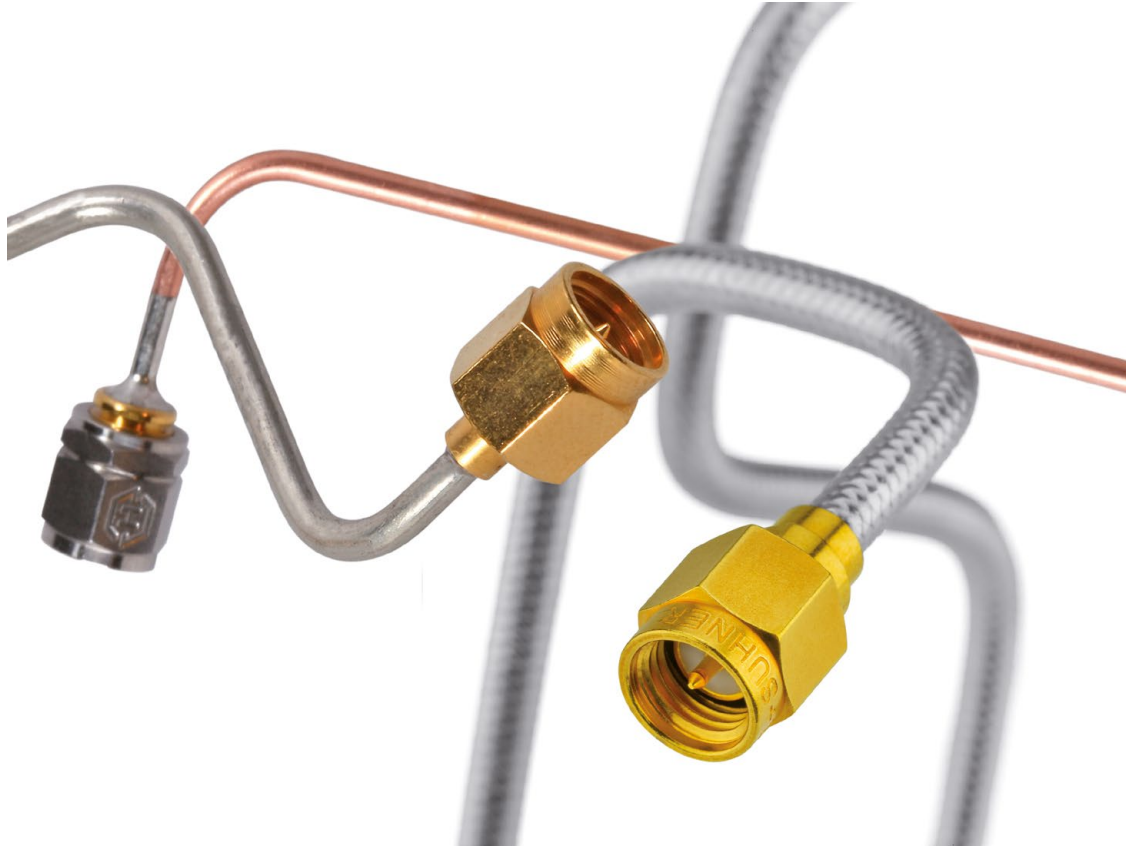

Handformable and formstable microwave cable assemblies

Sucoform microwave coaxial cables offer distinct mechanical advantages over semi-rigid cables. They are based on the same design as the standard PTFE insulated semi-rigid cables, but have a tin-soaked copper braid for the outer conductor, giving them outstanding hand-formability. These cables combine the excellent characteristics of semi-rigid cables with those of flexible coaxial cables. Thanks to their small bending radii, they allow spacesaving routing and packaging.

The semi-rigid cable is unique in that it is easily bent to finished shape and still maintains its set after bending. This property makes it ideal for use with automated bending equipment as well as hand forming by bending tools. The semi-rigid cables provide greatly extended environmental parameters. The cables exhibit highly favourable electrical characteristics, particularly an impedance tolerance as low as 0.5 Ohm for a 0.0141" diameter cable with nominal impedance of 50 Ohm.

Sucoform

The handformable alternative to semi-rigid

- Frequency range up to 40 GHz
- High phase stability
- Good flexibility
- Quick and easy assembling

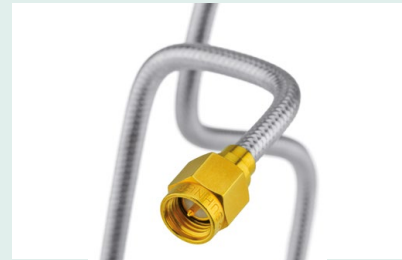

Semi-rigid

The form stable microwave cable

- High screening effectiveness of up to 120 dB @ 18 GHz
- Pre-bent to customer specifications for efficient, time-saving installation
- Easy to form, strip and solder
- Different cable diameters, from 0.020" up to 0.250"



Sucoform

The handformable alternative to semi-rigid

Product description

Sucoform microwave coaxial cables offer distinct mechanical advantages over semi-rigid cables. They are based on the same design as the standard PTFE insulated semi-rigid cables, but have a tin-soaked copper braid for the outer conductor, giving them outstanding hand-formability. These cables combine the excellent characteristics of semi-rigid cables with those of flexible coaxial cables. Thanks to their small bending radii, they allow space saving routing and packaging.



Product features

- Impedance 50 Ω
- Applicable up to 40 GHz
- Due to the high phase stability over every production run, Sucoform is especially suitable for delay lines
- Good flexibility: easy hand forming without tooling; fits into the smallest systems
- Quick and easy assembly for design and manufacture

Recommended connectors

SM_47_CU	MMCX, MCX, SMA, SK
SM_86	MCX, MMCX, SMA, SMB, SMC, PC3.5, SK, QMA, TNC, N
SM_141	SMA, PC3.5, QMA, TNC, N, QN
SM_250-01	SMA, N, 7/16
	Other connectors available on request

Construction



Cable	Inner conductor ①	Dielectric ②	Outer conductor ③	Outer diameter	Screening effectiveness up to 18 GHz
				mm	dB
SM_47_CU	CuAg Wire	PTFE	Sn soaked Cu braid	1.2	> 90
SM_86	StCuAg Wire	PTFE	Sn soaked Cu braid	2.1	> 90
SM_141	StCuAg Wire	PTFE	Sn soaked Cu braid	3.6	> 90
SM_250-01	CuAg Wire	PTFE	Sn soaked Cu braid	6.3	> 90

Sucoform cables are available with different jackets, inner conductor materials and impedances.

Technical data

Cable	Item no.	Max. operating frequency	Velocity of propagation	Weight g/m	Min. bending radii		Temperature range °C
		GHz	%		static mm	repeated mm	
SM_47_CU	23033515	40	71	6	3.18	n/a	-65 to +165
SM_86	22511613	40	71	15	6	20	-65 to +165
SM_141	22511925	33	71	40	8	40	-65 to +165
SM_250-01	84007938	18	71	130	30	120	-65 to +165

Sucoform

Attenuation (nominal values at +25 °C ambient temperature)

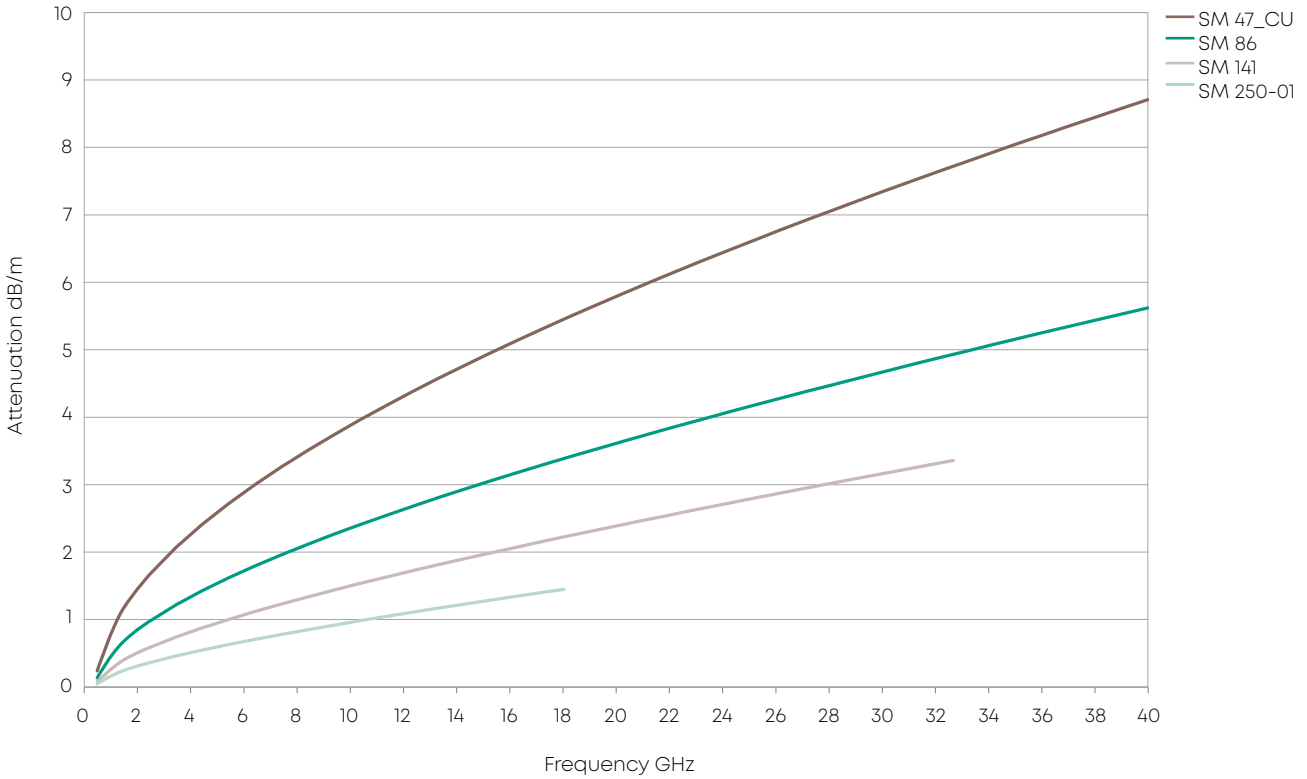

Power handling (maximum values at 25 °C ambient temperature and sea level)

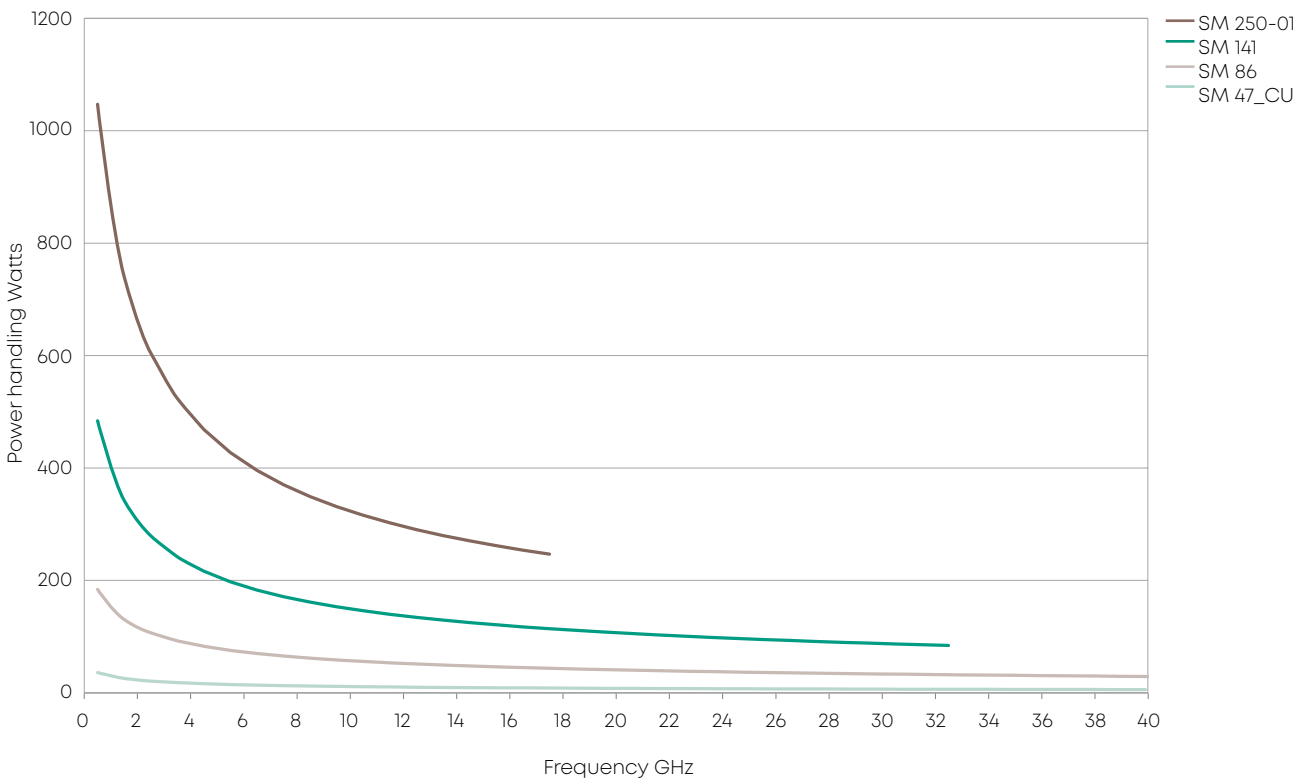

Sucoform – with protective jacket

Construction

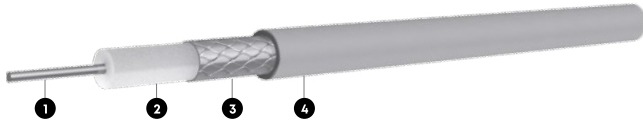

Cable	Inner conductor ①	Dielectric ②	Outer conductor ③	Jacket ④	Outer diameter mm	Screening effectiveness up to 18 GHz dB
SM_47_CU_LSFH	CuAg Wire	PTFE	Sn soaked Cu braid	LSFH	1.7	> 90
SM_86_PE	StCuAg Wire	PTFE	Sn soaked Cu braid	PE	3.2	> 90
SM_86_FEP	StCuAg Wire	PTFE	Sn soaked Cu braid	FEP	2.5	> 90
SM_141_CU_PE	CuAg Wire	PTFE	Sn soaked Cu braid	PE	4.6	> 90
SM_141_CU_FEP	CuAg Wire	PTFE	Sn soaked Cu braid	FEP	4.1	> 90
SM_250-01_FEP	CuAg Wire	PTFE	Sn soaked Cu braid	FEP	6.8	> 90

Sucoform cables are available with different inner conductor materials and impedances.

Technical data

Cable	Item no.	Max. operating frequency	Velocity of propagation	Weight g/m	Min. bending radii		Temperature range °C
		GHz	%		static mm	repeated mm	
SM_47_CU_LSFH	23035506	40	71	7	4	n/a	-40 to +85
SM_86_PE	22511631	40	71	19	6	20	-40 to +85
SM_86_FEP	22511942	40	71	18	6	20	-65 to +165
SM_141_CU_PE	22511639	33	71	47	8	40	-40 to +85
SM_141_CU_FEP	22512256	33	71	47	8	40	-65 to +165
SM_250-01_FEP	84007941	18	71	138	30	120	-65 to +165

Sucoform – with protective jacket

Attenuation (nominal values at +25 °C ambient temperature)

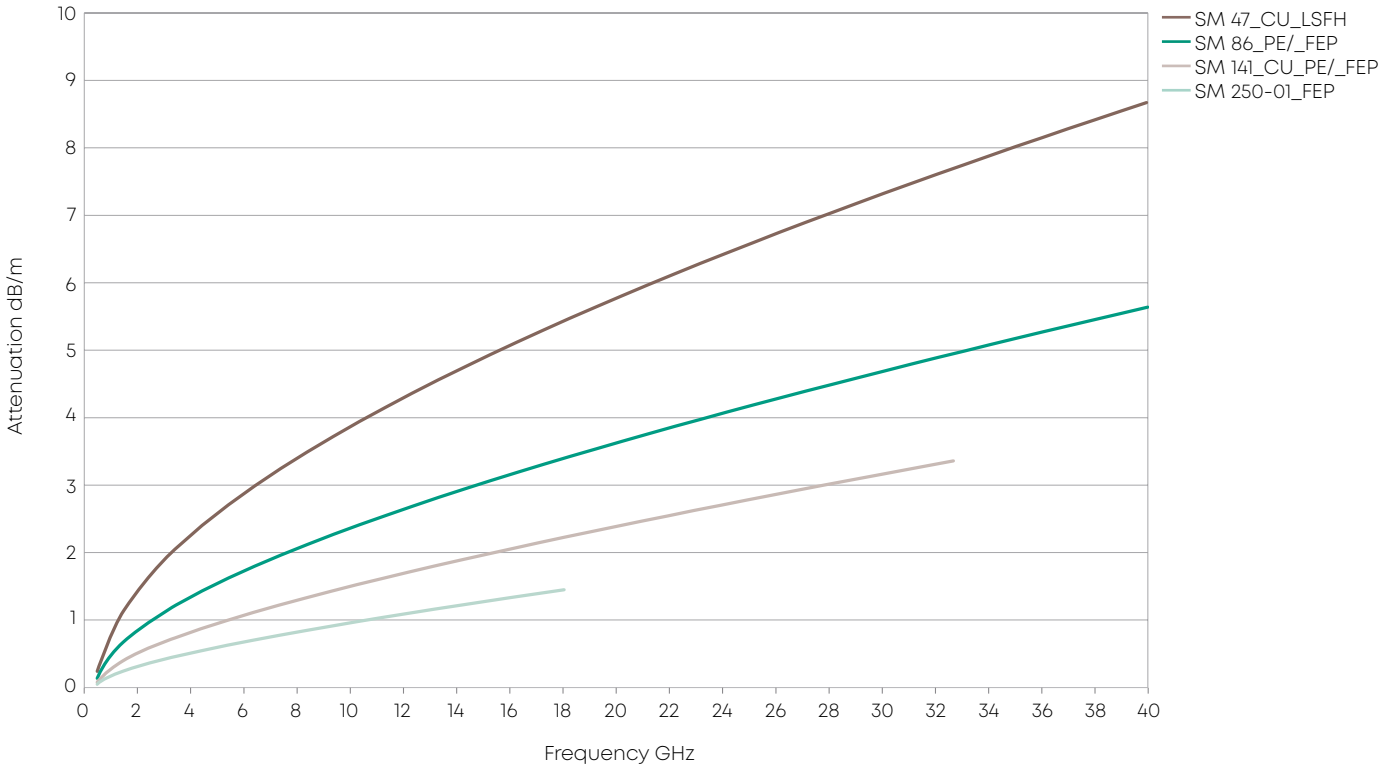

Power handling (maximum values at 25 °C ambient temperature and sea level)

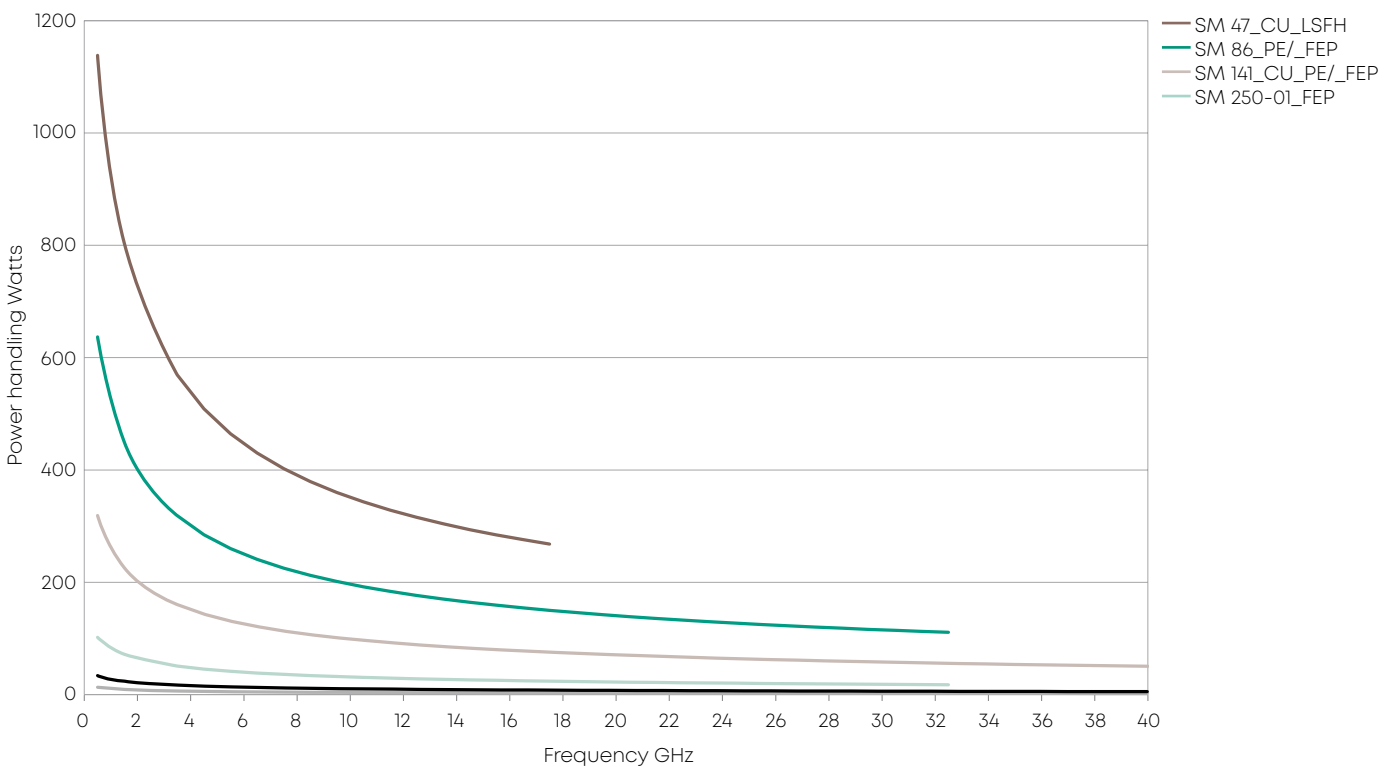

RF cable assembly SPJ/SM

Standard plenum jumper with Sucoform cables

Cable types	Cable attenuation	Jacket diameter	Bending radius
Sucoform 122 LA Cu CMP	0.66 dB/m @ 2.7 GHz	3.75 mm	min. 5 mm
Sucoform 141 LA Cu CMP	0.61 dB/m @ 2.7 GHz	4.20 mm	min. 8 mm
Sucoform 222 LA Cu CMP	0.41 dB/m @ 2.7 GHz	6.20 mm	min. 25 mm

Connector types	Male straight	Male angle	Female straight
DIN 7/16	X	X	X
DIN 4.1/9.5	X	X	X
N	X	X	X
4.3-10-X (HEX. Nut)	X	X	X
SMA	X	X	X
QMA	X		
NEX10	X	X	X

Technical data			
Frequency range	DC up to 6 GHz		
Return loss	Frequency	Straight/straight	Straight/angle
	0.38 to 1.0 GHz	≥ 29 dB	≥ 28 dB
	up to 2.2 GHz	≥ 27 dB	≥ 25 dB
	up to 2.7 GHz	≥ 26 dB	≥ 24 dB
	up to 3.8 GHz	≥ 23 dB	≥ 20 dB
up to 6 GHz	≥ 20 dB	≥ 19 dB	
PIM performance at 1.8GHz 2x 43dBm	≤ 160 dBc	typical -165 dBc	
	(QMA: ≤ 140 dBc)		

Environmental data	
Temperature range	-40 to 105 °C
Waterproof	IP67 (0.5 m/1 h/20 °C)
Cable performance	UV resistance
	UL444/CMP/FT6, ETL listed
	Jacket colour: white
Further information	100 % tested for return loss, attenuation and PIM Serial product label on each jumper for tracking Stock items in lengths of 0.5 up to 5 m



Sucoform

Available connectors

Connector	Series, pattern	HUBER+SUHNER type	Cable	Operating frequency	Item no.
				GHz	
MCX	straight cable plug	11_MCX-50-1-14/111_NE	SM_47_CU	6	23032081
	right angle cable plug	16_MCX-50-1-12/111_NE		6	23024694
	straight panel bulkhead cable jack	24_MCX-50-1-3/111_NE		6	22641648
MMCX	straight cable plug	11_MMCX-50-1-3/111_OE	SM_47_CU	6	22648893
	right angle cable plug	16_MMCX-50-1-12/111_OE		6	84030531
	right angle cable plug	16_MMCX-50-1-4/111_OE		6	22649182
	straight panel bulkhead cable jack	24_MMCX-50-1-3/111_OE		6	22652326
SK	straight cable plug	11_SK-50-1-2/119_NE	SM_47_CU	40	84013232
SMA	straight cable plug	11_SMA-50-1-2/111_NE	SM_47_CU	18	22642388
	right angle cable plug	16_SMA-50-1-97/19-_NE		18	23024708
	straight cable jack	21_SMA-50-1-2/111_NE		18	22642386
	straight panel bulkhead cable jack	24_SMA-50-1-6/111_YH		18	23025035
MCX	straight cable plug	11_MCX-50-2-19/111_NE	SM_86	6	23024699
	right angle cable plug	16_MCX-50-2-104/111_NH-1		6	23032067
	right angle cable plug	16_MCX-50-2-104/111_NH		6	22658277
	straight panel bulkhead cable jack	24_MCX-50-2-3/111_NE		6	22543580
MMBX	straight cable plug	11_MMBX-50-2-4/111_NE	SM_86	12.4	84026769
	right angle cable plug	16_MMBX-50-2-4/111_NE		12.4	84026740
	straight panel bulkhead cable jack	24_MMBX-50-2-2/111_NH		12.4	23037876
MMCX	straight cable plug	11_MMCX-50-2-1/111_OE	SM_86	6	22645297
	right angle cable plug	16_MMCX-50-2-1/111_OE		6	22645957
	straight cable jack	21_MMCX-50-2-1/111_OE		6	22645290
	straight panel bulkhead cable jack	24_MMCX-50-2-1/111_OE		6	22645954
N	straight cable plug	11_N-50-2-15/113_UE	SM_86	18	22660315
	right angle cable plug	16_N-50-2-9/13-_UH		11	23013729
	straight cable jack	21_N-50-2-14/133_NE		18	22642666
	straight panel bulkhead cable jack	24_N-50-2-14/133_NE		18	22544637
	straight panel cable jack, flange mount	25_N-50-2-14/133_NE		18	22641303
PC3.5	straight cable plug	11_PC35-50-2-4/199_UE	SM_86	33	84009440
	straight cable jack	21_PC35-50-2-4/199_UE		33	84009419
	straight panel bulkhead cable jack	24_PC35-50-2-2/199_UE		33	84009405
QMA	straight cable plug	11_QMA-50-2-3/133_NE	SM_86	6	23017704
	right angle cable plug	16_QMA-50-2-3/133_NE		6	23017666
	straight panel bulkhead cable jack	24_QMA-50-2-1/111_NE		6	23017742
SK	straight cable plug	11_SK-50-2-56/119_NE	SM_86	40	84013230
	straight cable jack	21_SK-50-2-58/199_NE		40	84019664
SMA	straight cable plug	11_SMA-50-2-15/111_NE	SM_86	18	22544545
	straight cable plug	11_SMA-50-2-110/133_NE		18	84130715
	right angle cable plug	16_SMA-50-2-43/133_NE		18	22641953
	right angle cable plug	16_SMA-50-2-100/199_NH		26.5	23018813

Sucoform

Connector	Series, pattern	HUBER+SUHNER type	Cable	Operating frequency	Item no.
				GHz	
SMA	straight cable jack	21_SMA-50-2-15/111_NE	SM_86	18	22544549
	straight panel bulkhead cable jack	24_SMA-50-2-15/111_NE		18	22544532
	straight panel bulkhead cable jack	24_SMA-50-2-41/133_NE		18	22641381
SMB	straight cable plug	11_SMB-50-2-13/111_NE	SM_86	4	22543362
	right angle cable plug	16_SMB-50-2-23/111_NE		4	22644079
	straight panel bulkhead cable jack	24_SMB-50-2-13/111_NE		4	22640822
SMC	straight cable plug	11_SMC-50-2-13/111_NE	SM_86	10	22543363
	right angle cable plug	16_SMC-50-2-25/111_NE		10	22644126
	straight panel bulkhead cable jack	24_SMC-50-2-13/111_NE		10	22640297
TNC	straight cable plug	11_TNC-50-2-20/103_NE	SM_86	11	22642519
	straight panel bulkhead cable jack	24_TNC-50-2-31/133_NE		11	23001721
N	straight cable plug	11_N-50-3-13/113_NE	SM_141	11	22542083
	straight cable plug	11_N-50-3-51/133_NE		18	22543919
	right angle cable plug	16_N-50-3-15/133_NE		11	22648832
	straight cable jack	21_N-50-3-51/19-_NE		18	22543922
	straight panel bulkhead cable jack	24_N-50-3-51/19-_NE		18	22642344
	straight panel cable jack, flange mount	25_N-50-3-9/133_NE		11	22543952
PC3.5	straight cable plug	11_PC35-50-3-4/199_UE	SM_141	33	84009380
	straight cable jack	21_PC35-50-3-3/199_UE		33	84009382
	straight panel bulkhead cable jack	24_PC35-50-3-2/199_UE		33	84009383
QMA	straight cable plug	11_QMA-50-3-3/133_NE	SM_141	6	23017695
	right angle cable plug	16_QMA-50-3-3/133_NE		6	23017693
	straight panel bulkhead cable jack	24_QMA-50-3-3/111_NE		6	23017683
QN	straight cable plug	11_QN-50-3-3/113_NE	SM_141	11	23033393
	right angle cable plug	16_QN-50-3-3/13-_NE		11	23033268
	straight panel bulkhead cable jack	24_QN-50-3-3/13-_NE		11	23033423
SMA	straight cable plug	11_SMA-50-3-77/119_NH	SR_141	18	84005524
	straight cable plug	11_SMA-50-3-235/133_NE		18	84130698
	right angle cable plug	16_SMA-50-3-3/111_NE		18	22640073
	right angle cable plug	16_SMA-50-3-13/133_NE		18	84130707
	straight cable jack	21_SMA-50-3-15/111_NE		18	22544550
	straight panel bulkhead cable jack	24_SMA-50-3-15/111_NE		18	22641153
TNC	straight cable plug	11_TNC-50-3-29/103_NE	SR_141	11	22641997
	right angle cable plug	16_TNC-50-3-24/13-_NE		11	84021420
	straight panel bulkhead cable jack	24_TNC-50-3-30/133_NH		11	23001723
7/16	straight cable plug	11_716-50-5-6/003_Y	SM_250-01	7.5	84008435
	straight panel cable jack, flange mount	25_716-50-5-17/000_Y		7.5	84008881
N	straight cable plug	11_N-50-5-18/103_NH	SM_250-01	11	84008445
	right angle cable plug	16_N-50-5-7/13-_H		7.5	21000191
SMA	straight cable plug	11_SMA-50-5-1/111_NE	SM_250-01	18	22642399

Semi-rigid

The copper form stable microwave cable

Product description

The semi-rigid cable is unique in that it is easily bent to finished shape and still maintains its set after bending. This property makes it ideal for use with automated bending equipment as well as hand forming by bending tools.



Product features

- Impedance 50 Ω
- High screening effectiveness of up to 120 dB @ 18 GHz
- Excellent VSWR performance
- Pre-bent to customer's specifications and for efficient, time-savings installations
- Different cable diameters, from 0.020" up to 0.250"

Recommended connectors

SR_47	MMCX, MCX, SMA, SK
SR_86	MCX, MMCX, SMA, PC3.5, SK, QMA, TNC, N, BNC
SR_118	SK
SR_141	SMA, PC3.5, QMA, TNC, N, QN
SR_250	SMA, N, 7/16
	Other connectors available on request.

Construction



Cable	Inner conductor ①	Dielectric ②	Outer conductor ③	Outer Diameter	Screening effectiveness up to 18 GHz
				mm	dB
SR_47_TP_M17	StCuAg Wire	PTFE	CuSn tube	1.2	120
SR_86_TP_M17	StCuAg Wire	PTFE	CuSn tube	2.2	120
SR_118_TP	StCuAg Wire	PTFE	CuSn tube	3.0	120
SR_141_TP_M17	StCuAg Wire	PTFE	CuSn tube	3.6	120
SR_250_TP_M17	CuAg Wire	PTFE	CuSn tube	6.4	120

Other semi rigid cables available on request (e.g. other impedances, other conductor materials).
Standard form of bulk delivery = 100 ft coils (30.48 m), shorter lengths on request.

Technical data

Cable	Item no.	Max. operating frequency	Velocity of propagation	Weight	Min. bending radius		Temperature range
		GHz	%		static mm	repeated mm	°C
SR_47_TP_M17	22810504	107	69.5	71	3.18	n/a	-55 to +100
SR_86_TP_M17	22810175	40	69.5	24	3.18	n/a	-55 to +125
SR_118_TP	22810073	40	80.0	34	9.53	n/a	-55 to +125
SR_141_TP_M17	22810043	33	69.5	52	9.52	n/a	-55 to +100
SR_250_TP_M17	22810705	18	69.5	158	19.0	n/a	-55 to +100

Semi-rigid

The aluminium form stable microwave cable

Product description

The semi-rigid cable is unique in that it is easily bent to finished shape and still maintains its set after bending. This property makes it ideal for use with automated bending equipment as well as hand forming by bending tools.

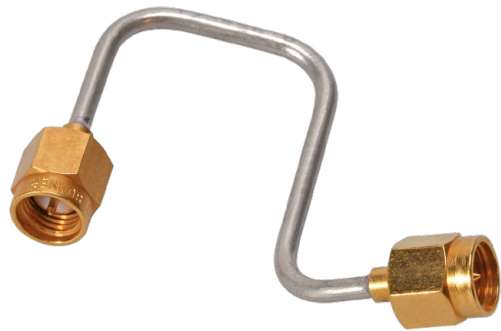

Product features

- Impedance 50 Ω
- High screening effectiveness of up to 120 dB @ 18 GHz
- Excellent VSWR performance
- Pre-bent to customer's specifications and for efficient, time-savings installations
- Different cable diameters, from 0.020" up to 0.250"

Recommended connectors

SR_47	MMCX, MCX, SMA, SK
SR_86	MCX, MMCX, SMA, PC3.5, SK, QMA, TNC, N, BNC
SR_118	SK
SR_141	SMA, PC3.5, QMA, TNC, N, QN
SR_250	SMA, N, 7/16
	Other connectors available on request.

Construction



Cable	Inner conductor ①	Dielectric ②	Outer conductor ③	Outer diameter	Screening effectiveness up to 18 GHz
				mm	dB
SR_47_AL_TP_M17	StCuAg Wire	PTFE	AlSn tube	1.2	120
SR_86_AL_TP_M17	StCuAg Wire	PTFE	AlSn tube	2.2	120
SR_141_AL_TP_M17	StCuAg Wire	PTFE	AlSn tube	3.6	120
SR_250_AL_TP_M17	CuAg Wire	PTFE	AlSn tube	6.4	120

Other semi rigid cables available on request (e.g. other impedances, other conductor materials).
Standard form of bulk delivery = 100 ft coils (30.48 m), shorter lengths on request.

Technical data

Cable	Item no.	Max. operating frequency	Velocity of propagation	Weight	Min. bending radius		Temperature range
		GHz	%		static mm	repeated mm	°C
SR_47_AL_TP_M17	22810510	107	69.5	3.1	1.27	n/a	-55 to +100
SR_86_AL_TP_M17	22810167	40	69.5	11.9	1.78	n/a	-40 to +125
SR_141_AL_TP_M17	22810015	33	69.5	30.5	6.35	n/a	-40 to +125
SR_250_AL_TP_M17	22810708	18	69.5	88.6	19.0	n/a	-55 to +100

Semi-rigid

Attenuation (nominal values at +25 °C ambient temperature)

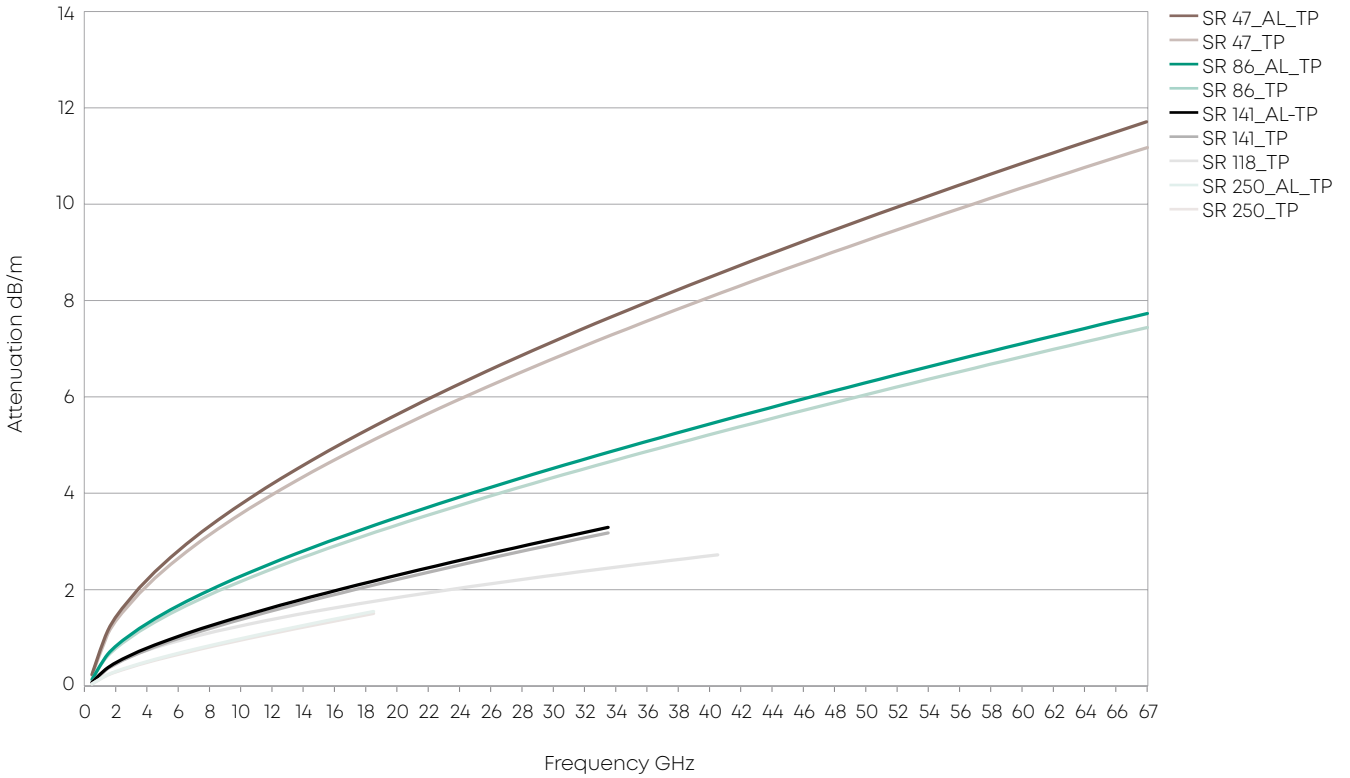

Power handling (maximum values at 25 °C ambient temperature and sea level)

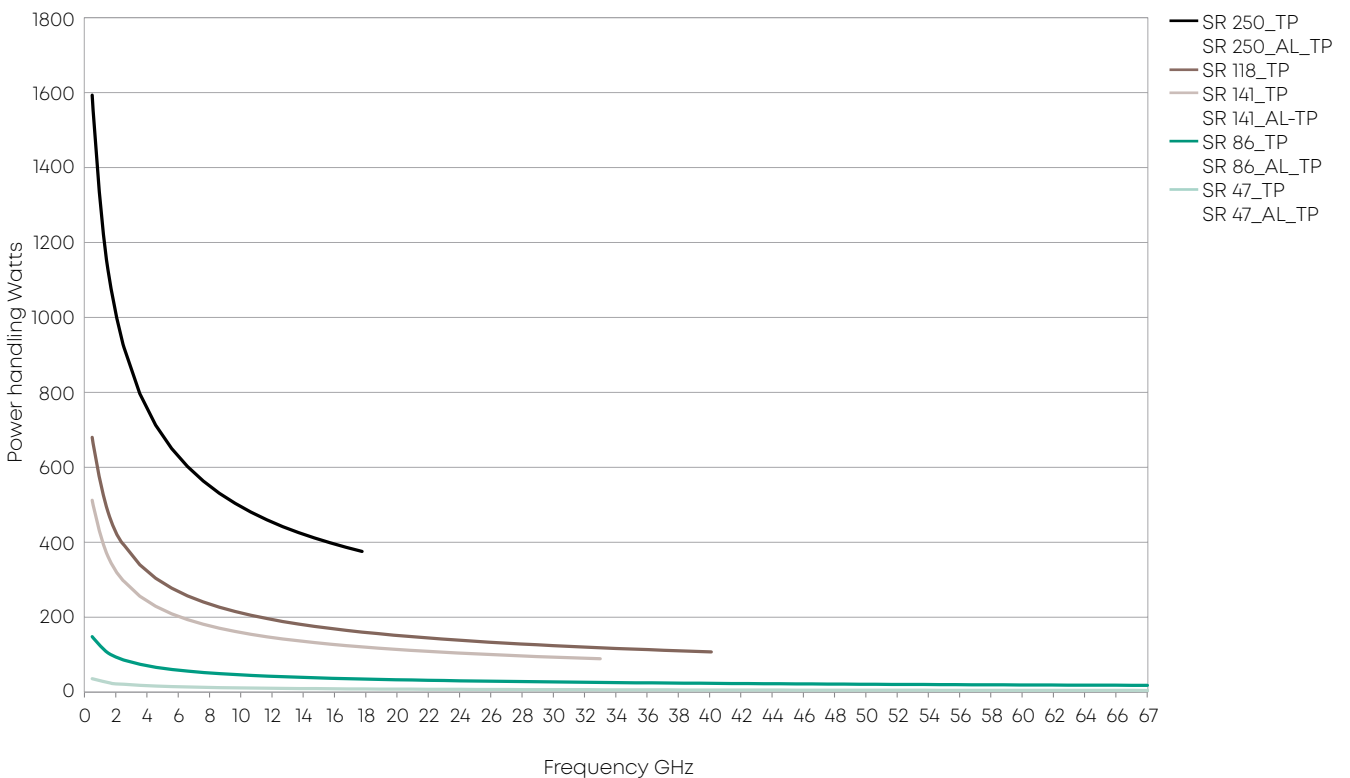

Semi-rigid

Available connectors

Connector	Series, pattern	HUBER+SUHNER type	Cable	Operating frequency	Item no.
				GHz	
MCX	straight cable plug	11_MCX-50-1-14/111_NE	SR_47	6	23032081
	right angle cable plug	16_MCX-50-1-11/111_NE		6	23024700
	straight panel bulkhead cable jack	24_MCX-50-1-3/111_NE		6	22641648
MMCX	straight cable plug	11_MMCX-50-1-3/111_OE	SR_47	6	22648893
	right angle cable plug	16_MMCX-50-1-4/111_OE		6	22649182
SK	straight cable plug	11_SK-50-1-2/119_NE	SR_47	40	84013232
SMA	straight cable plug	11_SMA-50-1-53/119_NH	SR_47	18	23013327
	right angle cable plug	16_SMA-50-1-97/19-_NE		18	23024708
	straight cable jack	21_SMA-50-1-2/111_NE		18	22642386
	straight panel bulkhead cable jack	24_SMA-50-1-6/111_YH		18	23025035
BNC	straight cable plug (male)	11_BNC-50-2-20/103_NE	86	4	22641778
MCX	straight cable plug	11_MCX-50-2-19/111_NE	SR_86	6	23024699
	right angle cable plug	16_MCX-50-2-104/111_NH-1		6	23032067
	right angle cable plug	16_MCX-50-2-104/111_NH		6	22658277
	straight panel bulkhead cable jack	24_MCX-50-2-3/111_NE		6	22543580
MMCX	straight cable plug	11_MMCX-50-2-1/111_OE	SR_86	6	22649039
	right angle cable plug	16_MMCX-50-2-1/111_OE		6	22645957
	straight cable jack	21_MMCX-50-2-1/111_OE		6	22645290
	straight panel bulkhead cable jack	24_MMCX-50-2-1/111_OE		6	22645954
N	straight cable plug	11_N-50-2-15/113_UE	SR_86	18	22660315
	right angle cable plug	16_N-50-2-9/13-_UH		11	23013729
	straight cable jack	21_N-50-2-14/133_NE		18	22642666
	straight panel bulkhead cable jack	24_N-50-2-14/133_NE		18	22544637
PC3.5	straight cable plug	11_PC35-50-2-4/199_UE	SR_86	33	84009440
	straight cable jack	21_PC35-50-2-4/199_UE		33	84009419
	straight panel bulkhead cable jack	24_PC35-50-2-2/199_UE		33	84009405
QMA	straight cable plug	11_QMA-50-2-3/133_NE	SR_86	6	23017704
	straight panel bulkhead cable jack	24_QMA-50-2-1/111_NE		6	23017742
SK	straight cable plug	11_SK-50-2-56/119_NE	SR_86	40	84013230
SMA	straight cable plug	11_SMA-50-2-15/111_NE	SR_86	18	22544545
	straight cable plug	11_SMA-50-2-110/133_NE		18	84130715
	right angle cable plug	16_SMA-50-2-43/133_NE		18	22641953
	right angle cable plug	16_SMA-50-2-100/199_NH		26.5	23018813
	straight cable jack	21_SMA-50-2-15/111_NE		18	22544549
	straight panel bulkhead cable jack	24_SMA-50-2-15/111_NE		18	22544532
	straight panel bulkhead cable jack	24_SMA-50-2-41/133_NE		18	22641381
TNC	straight cable plug	11_TNC-50-2-20/103_NE	SR_86	11	22642519
	straight panel bulkhead cable jack	24_TNC-50-2-31/133_NE		11	23001721

Semi-rigid

Connector	Series, pattern	HUBER+SUHNER type	Cable	Operating frequency	Item no.
				GHz	
SK	straight cable plug	11_SK-50-2-51/119_NE	SR_118	40	22645972
	straight cable jack	21_SK-50-2-51/199_NE		40	22645973
	straight panel bulkhead cable jack	24_SK-50-2-55/1--_NE		40	84016419
N	straight cable plug	11_N-50-3-13/113_NE	SR_141	11	22542083
	straight cable plug	11_N-50-3-51/133_NE		18	22543919
	right angle cable plug	16_N-50-3-15/133_NE		11	22648832
	straight cable jack	21_N-50-3-51/19-_NE		18	22543922
	straight panel bulkhead cable jack	24_N-50-3-51/19-_NE		18	22642344
PC3.5	straight cable plug	11_PC35-50-3-4/199_UE	SR_141	33	84009380
	straight cable jack	21_PC35-50-3-3/199_UE		33	84009382
	straight panel bulkhead cable jack	24_PC35-50-3-2/199_UE		33	84009383
QMA	straight cable plug	11_QMA-50-3-3/133_NE	SR_141	6	23017695
	right angle cable plug	16_QMA-50-3-3/133_NE		6	23017693
	straight panel bulkhead cable jack	24_QMA-50-3-3/111_NE		6	23017683
QN	straight cable plug	11_QN-50-3-3/113_NE	SR_141	11	23033393
	right angle cable plug	16_QN-50-3-3/13-_NE		11	23033268
	straight panel bulkhead cable jack	24_QN-50-3-3/13-_NE		11	23033423
SMA	straight cable plug	11_SMA-50-3-77/119_NH	SR_141	18	84005524
	straight cable plug	11_SMA-50-3-235/133_NE		18	84130698
	right angle cable plug	16_SMA-50-3-3/111_NE		18	22640073
	right angle cable plug	16_SMA-50-3-13/133_NE		18	84130707
	straight cable jack	21_SMA-50-3-15/111_NE		18	22544550
	straight panel bulkhead cable jack	24_SMA-50-3-15/111_NE		18	22641153
TNC	straight cable plug	11_TNC-50-3-29/103_NE	SR_141	11	22641997
	right angle cable plug	16_TNC-50-3-24/13-_NE		11	84021420
	straight panel bulkhead cable jack	24_TNC-50-3-30/133_NH		11	23001723
7/16	straight cable plug	11_716-50-5-6/003_Y	SR_250	7.5	84008435
	straight panel cable jack, flange mount	25_716-50-5-17/000_Y		7.5	84008881
N	straight cable plug	11_N-50-5-18/103_NH	SR_250	11	84008445
	straight cable plug	11_N-50-5-39/133_NE		18	22642481
	straight panel bulkhead cable jack	24_N-50-5-39/133_NE		18	22642505
SMA	straight cable plug	11_SMA-50-5-1/111_NE	SR_250	18	22642399
	straight cable plug	11_SMA-50-5-2/199_NE		18	22643253

CT product family

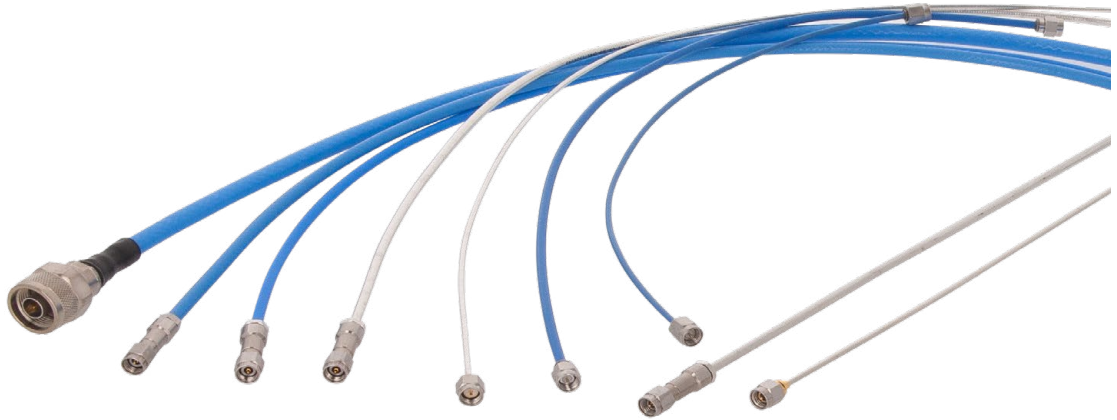

Features

- Excellent phase and insertion loss stability over temperature
- Superior phase stability versus bending
- Outstanding return loss and shielding effectiveness performance
- Easy installation
- Small bending radii

Benefits

- Increased system accuracy over temperature change
- Stable system performance over multiple temperature cycles
- Product reliability - meeting the specified values not only at one single temperature

CT product family

The HUBER+SUHNER CT product family is developed for phase critical applications requiring precision electrical length connectivity. Thus, it creates a stable and reliable interconnect solution to satisfy a huge range of customer applications where phase stability is key.

These products provide the industry leading phase vs. temperature performance, as well as a unique range of cable constructions to fulfil any customer demands.

Depending on the application, there is a broad variety of products lines available:

Sucoform CT Hand formable, form stable cable with tin soaked braid outer conductor

Semi-rigid CT Form stable cable with tubular, tin plated outer conductor

Minibend CT Flexible cable assembly with bend-to-the-end connector termination

Multiflex CT Flexible alternative to Semi-Rigid microwave cables

CT Portfolio Overview

	0.086"	0.141"	0.210"	0.318"
Semi-rigid	✓	✓		
Sucoform	✓	✓		
Minibend	✓	✓		
Multiflex		✓	✓	✓

Comparison of a typical phase stability versus temperature: CT Dielectric and Low Density PTFE

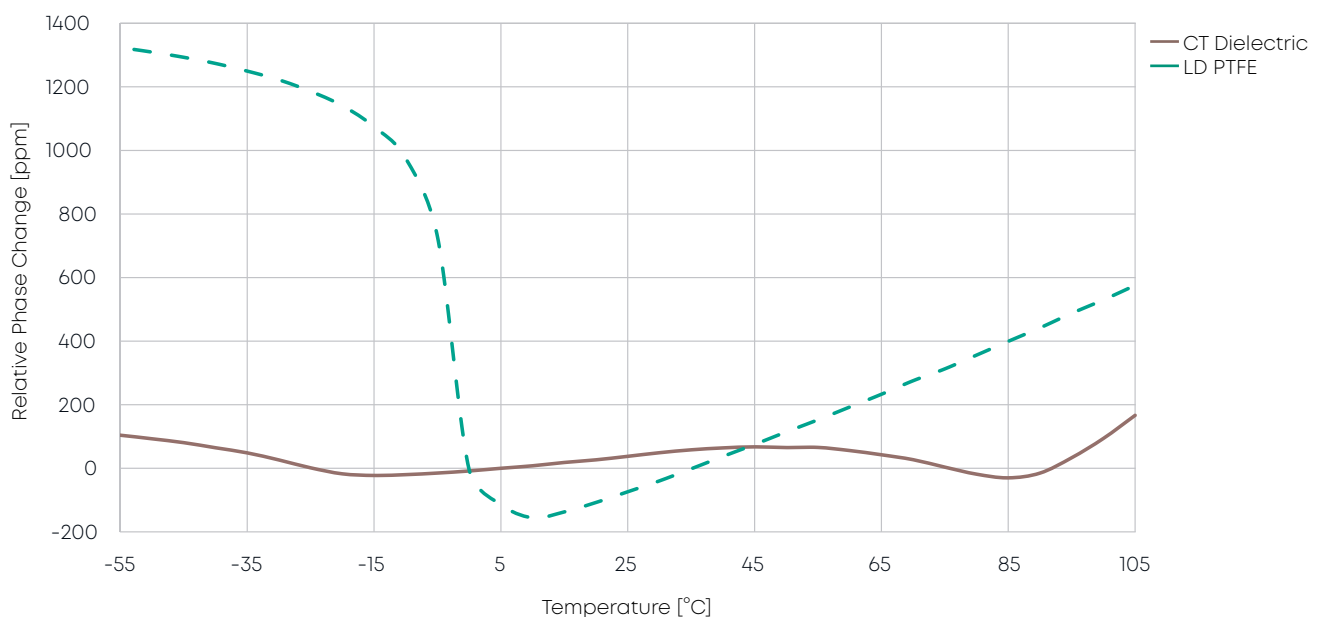

Sucoform CT



Benefits

- Static applications
- Frequency range up to 40GHz
- Space and time saving routing
- Quick and easy assembling

Phase Stability vs Temperature (Typical)

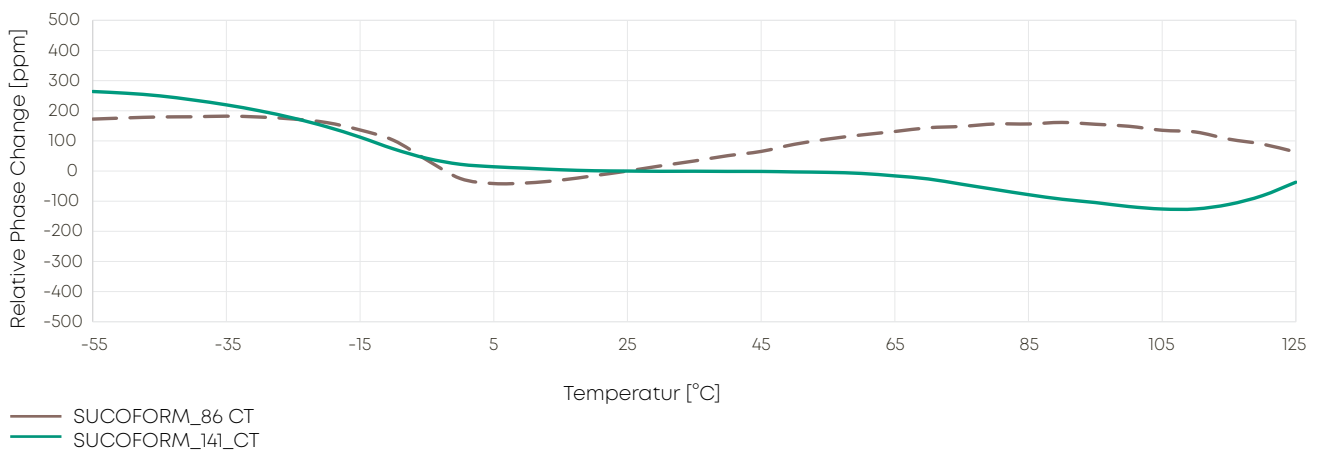

Product Overview

Description	Frequency range	Insertion loss @18GHz	Outer diameter	Connectors
Sucoform_86_CT	40 GHz	3.18 dB/m	2.15 mm	SK, SMA, MMPX
Sucoform_141_CT	30 GHz	1.93 dB/m	3.58 mm	SK, SMA, BMA

Semi-rigid CT



Benefits

- Static applications
- Frequency range up to 40GHz
- High screening effectiveness of up to 120 dB @ 18 GHz
- Space and time saving installation

Phase variation vs. temperature

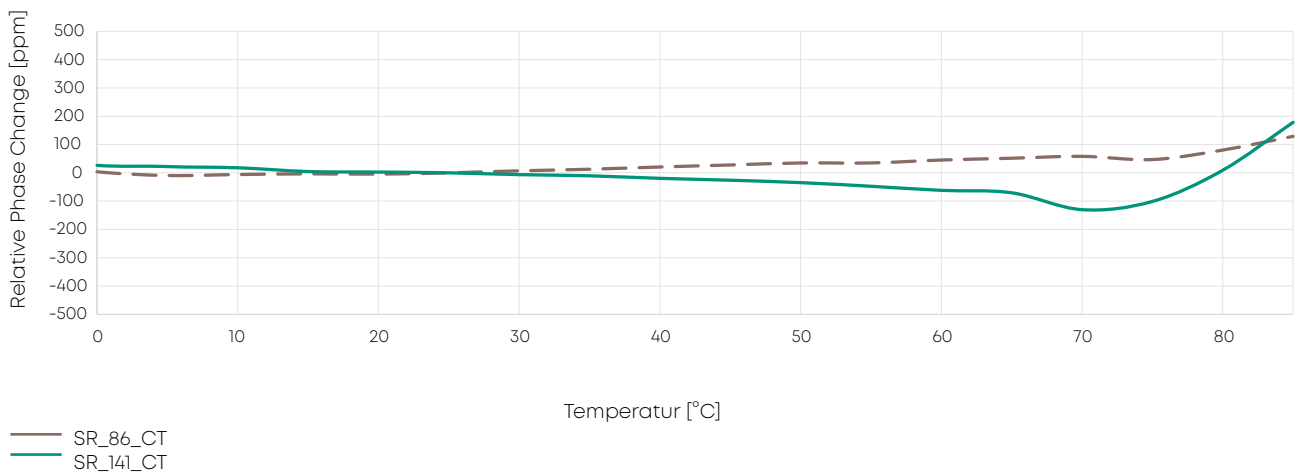

Product Overview

Description	Frequency range	Insertion loss @18GHz	Outer diameter	Connectors
SR_86_CT	40 GHz	2.59 dB/m	2.2 mm	SK, SMA, MMPX
SR_141_CT	33 GHz	1.8 dB/m	3.58 mm	SK, SMA

Minibend CT

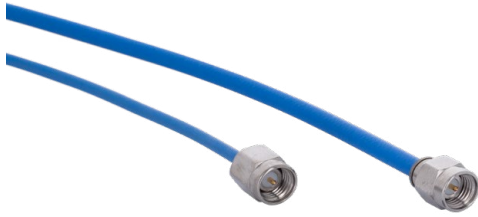

Benefits

- Flexible applications
- Bend-to-the-end technology
- Higher reliability due to solderless junctions
- MIL/DTL qualified

- Excellent phase and insertion loss stability over temperature
 minibend CTR: < 300 ppm absolute phase changeover -55 to +85 °C temperature range
 mini141 CT: < 800 ppm absolute phase changeover -55 to +85 °C temperature range
- Outstanding phase stability versus bending
 Phase vs flexure of 1.0° at 24 GHz
- Revolutionary minibend bend-to-the-end flexibility
 minibend CTR: 5 mm minimum bend radius applicable right behind the connector
 mini141 CT: 8.4 mm minimum bend radius applicable right behind the connector

Phase variation vs. temperature

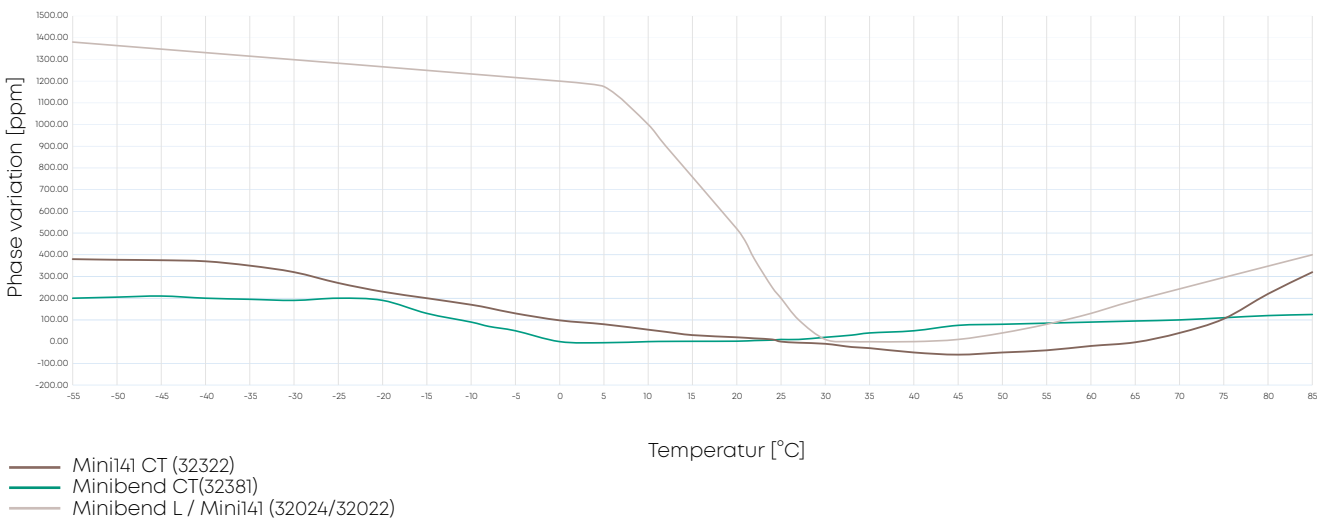

Product Overview

Description	Frequency range	Insertion loss @18GHz	Outer diameter	Connectors
Minibend CT (32381)	70 GHz	3.94 dB/m	2.54 mm	SMA, K, SMP, SMPM, SMPM-T, 1.85 mm
Mini141 CT (32322)	40 GHz	2.12 dB/m	3.66 mm	SMA, K, SMP

Minibend CTR / Mini141 CT

		MINIBEND CTR	MINI141 CT
SMA	Straight Male	29094CR-32381	29094CR-32322
	R/A Male	29200CR-32381	
	Straight Female	29092CR-32381	
	Bulkhead Female	29088CR-32381	29088CR-32322
	Flanged Female	29156CR-32381	
SMK (2.9)	Straight Male	29094KCR-32381	29094KCR-32322
	R/A Male	29200KCR-32381	
	Straight Female	29092KCR-32381	
	Flanged Female		29142KCR-32322
SMP	Bulkhead Male	29474C2R-32381	
	Straight Female	29473CR-32381	
	R/A Female	29477-32381	
	Flanged Female	29477F2-32381	
SMPM	Bulkhead Male	29972C2R-32-81	
	Straight Female	29981CR-32381	
	R/A Female	29983HT-32381	
SMPM-T	Straight Female	29971TCR-32381	
SSMA	R/A Male	29111-32381	
PC 2.4mm	Straight Male	29898CR-32381	
PC 1.85mm	Straight Male	29890CR-32381	
MMCX	R/A Male	29954-32381	
MMPX	Straight Male	29430CR-32381	

Multiflex CT



Benefits

- Flexible applications
- Frequency range up to 40 GHz
- Low loss
- Low weight

Phase Stability vs Temperature (Typical)

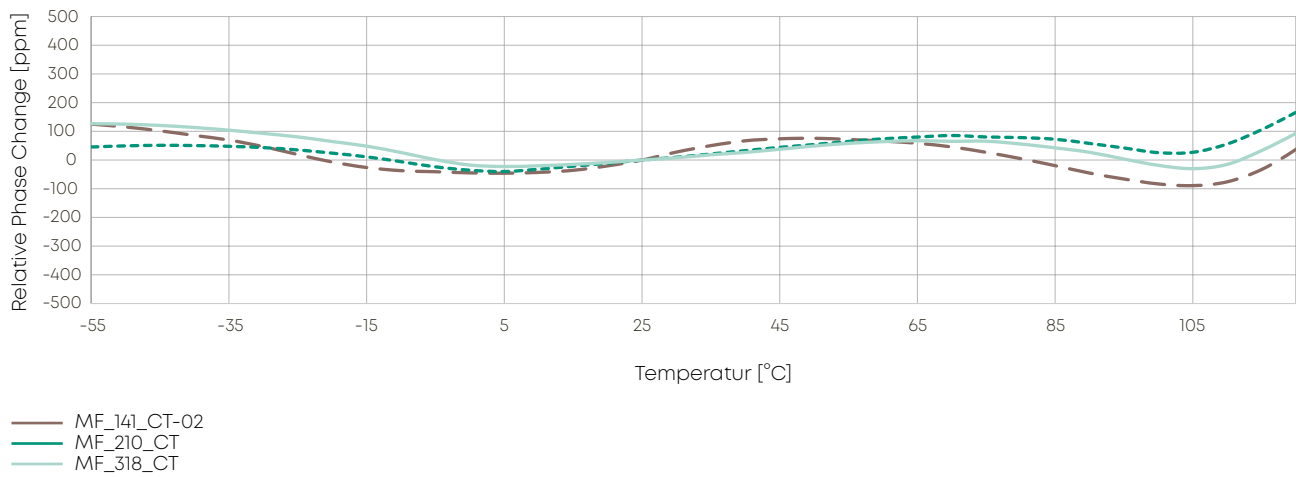

Product Overview

Description	Frequency range	Insertion loss @18GHz	Outer diameter	Connectors
MULTIFLEX_141_CT-02	40 GHz	2.0 dB/m	3.8 mm	SK, SMA
Multiflex_210_CT	30 GHz	1.4 dB/m	5.0 mm	SK, SMA, N, TNC
Multiflex_318_CT	18 GHz	1.0 dB/m	7.5 mm	SMA, N, TNC

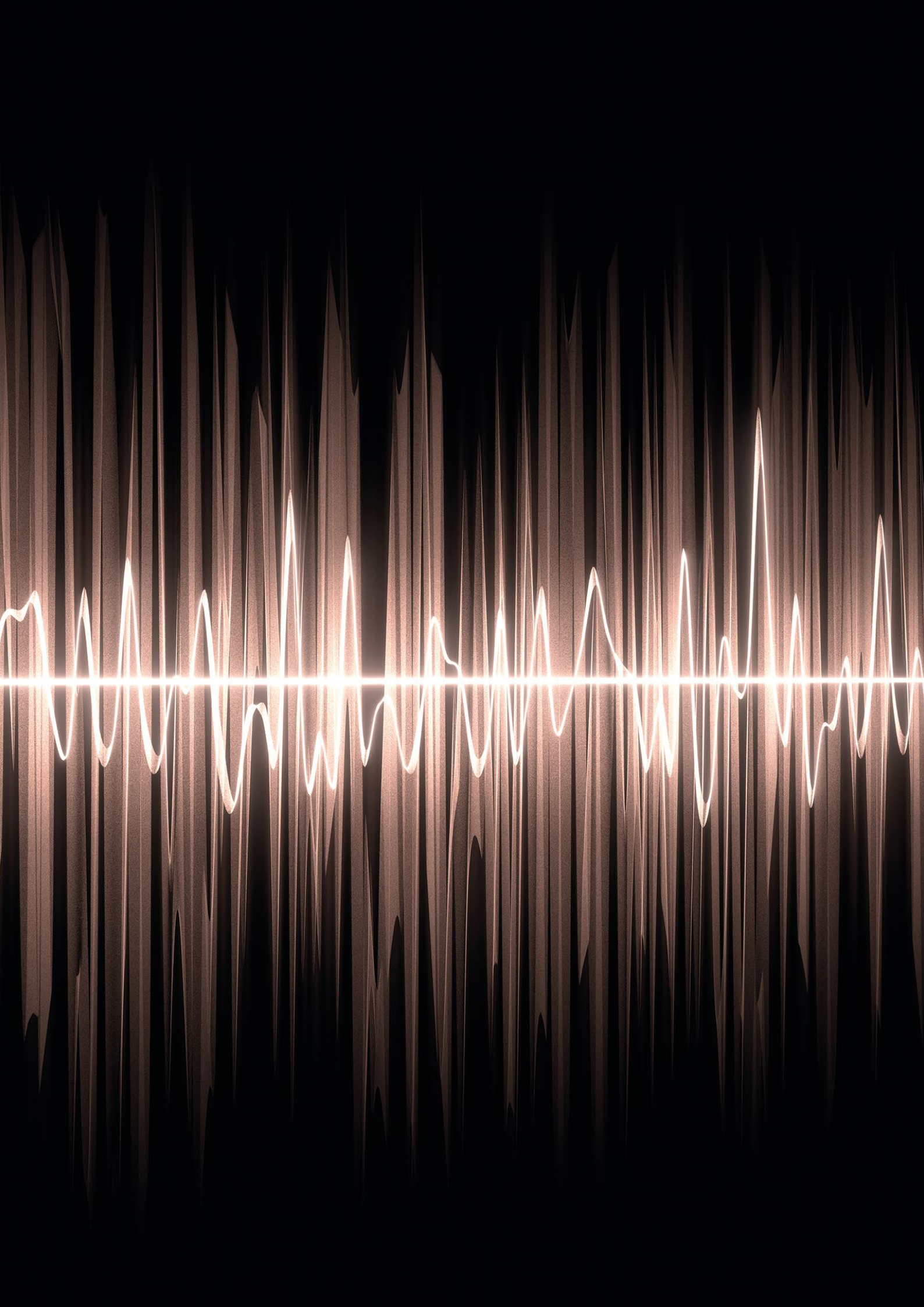

TVAC cable assemblies



Simulating the extreme conditions encountered in space imposes severe requirements on all components, from the test subject inside the thermal vacuum chamber through to the measurement installations on the outside. Exposure to rapid, large-scale thermal gradients within a vacuum environment requires carefully selected materials and designs that can mechanically and electrically withstand these extremes without the risk of multipaction and corona phenomena.

The use of high-power, low-outgassing materials, precision connector designs and innovative manufacturing techniques has allowed HUBER+SUHNER to provide durable, reliable TVAC cable assemblies and connector solutions for our customers within a broad range of TVAC applications.

Features

- In-house thermal aging of components
- Low outgassing materials in accordance with ECSS-Q-ST-70-02 C and NASA reference publication 1124
- Superior mechanical and electrical stability
- Perfectly matched cables and connectors from a single manufacturer
- Cable assemblies and components available for extremely high-power applications

Benefits

- Vented connectors for fast evacuation
- Longer lifetime, lower costs
- Customized configurations available

SUCOFLEX® 100 / 500 TVAC – the versatile all-rounder

- Frequency range up to 70 GHz
- Perfectly matched cables and connectors from one manufacturer
- Broad range of cables and connectors available
- Pure jacket and arms for superior flexibility
- Vented connectors
- Armed options available



32071 TVAC – for high power applications

- Frequency range up to 14 GHz
- Capable of 500 WCW power handling in an ambient environment of +150 °C and vacuum conditions
- Extensive thermal ageing and stabilisation of the cable assembly is a standard manufacturing process
- Straight TNC, N and SC connectors
- High reliability



Phase stable over temperature raw cables and assemblies

The HUBER+SUHNER CT product family is developed for phase critical applications requiring precision electrical length connectivity. Thus, it creates a stable and reliable interconnect solution to satisfy a huge range of customer applications where phase stability is key. These products provide the industry leading phase vs. temperature performance, as well as a unique range of cable constructions to fulfil any customer TVAC demands.



SUCOFLEX® 100 / 500



- High performance up to 70 GHz
- Reliable and robust, wide range of products
- Excellent return and insertion loss
- Compliant with ECSS-Q-ST-70-02 C outgassing standards
- Available as pre-terminated cable assemblies
- All components P+ (max. 10 pcs. available within 10 working days)

SUCOFLEX® 100 – TVAC cable assemblies

Cable type	Frequency range	Available vented connectors		Temperature range	Benefit
SUCOFLEX 570	DC-70 GHz	1.85mm straight male	SF_11_PC185-504 (1.85)	-55 to +125°C	connector not vented
SUCOFLEX 102	DC-40 GHz	2.92mm straight male	SF_11_SK-263_TVAC (2.92)	-40 to +85°C	flexible cable
SUCOFLEX 102_E	DC – 40 GHz	2.92mm straight male	SF_11_SK-263_TVAC (2.92)	-40 to +85°C	flexible jacket
SUCOFLEX 103_E	DC – 33 GHz	2.92mm straight male	SF_11_SK-312_TVAC (2.92)	-40 to +85°C	flexible jacket
SUCOFLEX 103_EA	DC – 33 GHz	2.92mm straight male	SF_11_SK-312_TVAC (2.92)	-40 to +85°C	highly flexible, crush-resistant armour
SUCOFLEX 104	DC – 18 GHz DC – 26.5 GHz DC – 18 GHz	SMA straight male 3.5mm straight male TNC straight male	SF_11_SMA-454_TVAC SF_11_PC35-411_TVAC (3.5) SF_11_TNC_476_TVAC	-55 to +125°C -55 to +90°C -55 to +125°C	
SUCOFLEX 104_E	DC – 18 GHz DC – 26.5 GHz DC – 18 GHz	SMA straight male 3.5mm straight male TNC straight male	SF_11_SMA-454_TVAC SF_11_PC35-411_TVAC (3.5) SF_11_TNC_476_TVAC	-40 to +85°C -40 to +85°C -40 to +85°C	flexible jacket
SUCOFLEX 104_EA	DC – 18 GHz DC – 26.5 GHz DC – 18 GHz	SMA straight male 3.5mm straight male TNC straight male	SF_11_SMA-454_TVAC SF_11_PC35-411_TVAC (3.5) SF_11_TNC_476_TVAC	-40 to +85°C -40 to +85°C -40 to +85°C	highly flexible, crush-resistant armour
SUCOFLEX 126	DC – 18 GHz DC – 26.5 GHz DC – 18 GHz	SMA straight male 3.5mm straight male TNC straight male	SF_11_SMA-454_TVAC SF_11_PC35-411_TVAC (3.5) SF_11_TNC_476_TVAC	-55 to +125°C -55 to +90°C -55 to +125°C	rotary swaged inner conductor, phase stable and long life time
SUCOFLEX 126_E	DC – 18 GHz DC – 26.5 GHz DC – 18 GHz	SMA straight male 3.5mm straight male TNC straight male	SF_11_SMA-454_TVAC SF_11_PC35-411_TVAC (3.5) SF_11_TNC_476_TVAC	-40 to +85°C -40 to +85°C -40 to +85°C	rotary swaged inner conductor, phase stable and long life time, flexible jacket
SUCOFLEX 126_EA	DC – 18 GHz DC – 26.5 GHz DC – 18 GHz	SMA straight male 3.5mm straight male TNC straight male	SF_11_SMA-454_TVAC SF_11_PC35-411_TVAC (3.5) SF_11_TNC_476_TVAC	-40 to +85°C -40 to +85°C -40 to +85°C	rotary swaged inner conductor, phase stable and long life time, highly flexible, crush-resistant armour
SUCOFLEX 106	DC – 18 GHz	TNC straight male	SF_11_TNC-682_TVAC	-55 to +125°C	

MULTIFLEX-CT



- High performance up to 40 GHz
- Superior phase and insertion loss stability vs. temperature
- Excellent overall system accuracy and reliability independent of temperature
- Compliant with ECSS-Q-ST-70-02 C outgassing standards
- Available as pre-terminated cable assemblies
- All components P+ (max. 10 pcs. available within 10 working days)

MULTIFLEX-CT – TVAC cable assemblies

Cable type	Frequency range	Available vented connectors		Temperature range	Benefit
MULTIFLEX_141_CT-02	DC – 40 GHz DC – 18 GHz	2.92mm straight male SMA straight male	11_SK-50-2-71/199_N (2.92) 11_SMA-50-2-103/199_N	-40 to +125°C -40 to +125°C	Excellent phase vs. temperature behaviour
MULTIFLEX_210_CT	DC – 30 GHz DC – 18 GHz	2.92mm straight male SMA straight male	11_SK-50-4-3/199_N (2.92) 11_SMA-50-4-106/199_N	-40 to +125°C -40 to +125°C	
MULTIFLEX_318_CT	DC – 18 GHz	N straight male	11_N-50-6-27/133_N	-40 to +125°C	

High power 32071 TVAC



- Frequency range up to 14 GHz
- Capable of 500 W CW power handling in an ambient environment of +150 °C and vacuum conditions
- Extensive thermal ageing and stabilisation of the cable assembly is a standard manufacturing process
- Straight TNC, N and SC connectors
- High reliability

Electrical specifications	
Impedance (nominal)	50 Ω
Velocity %	78
Operating frequency	DC – 14 GHz
Insertion loss variation vs. temperature	< 0.0015 °K ⁻⁶
Return loss (min)	-25 dB @ 2 GHz -27 dB @ 14 GHz
RF leakage	95 dB
Resistance – insulation cable	> 106 MΩ*m
Withstand voltage – cable assembly (at sea level)	> 10 000 V
Capacitance	85.9 pF*m ⁻⁶
Time delay	4.28 ns*m ⁻⁶
Phase variation vs. temperature	< 1500 ppm

Materials and finishes	
Cable center conductor	silver plated solid copper
Cable dielectric	tape wrapped PTFE
Cable shield	silver plated copper helical foil
Cable binder	silver plated flat copperwire braid
Cable jacket	extruded FEP

Cable mechanics	
Diameter	9.40 mm
Minimum bending radius – static	50.8 mm
Minimum bending radius – dynamic	152.4 mm
Cable retention force on ruggedized cable assemblies	135 N
Weight	208.4 g*m ⁻¹

Environmental specifications	
Temperature range	-55 to +200°C
Radiation resistance	30 Mrad
Out gassing according ECSS-Q-ST-70-02 and NASA reference publication 1124	TML < 1 %, CVCM < 0.1 %

CW power 32071 with TNC connectors

CW power max. vs. frequency

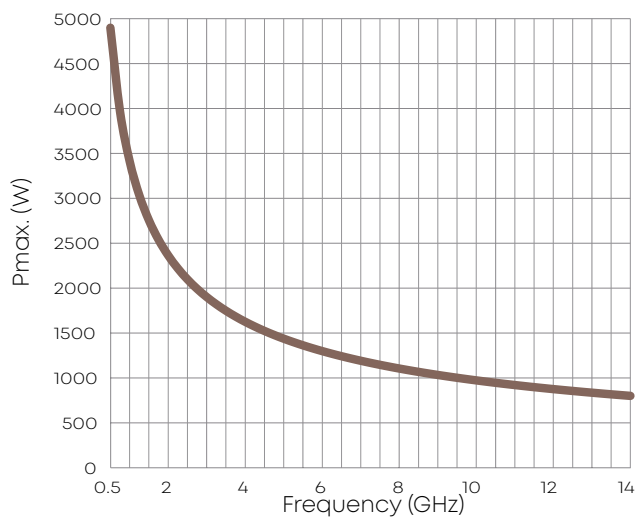

— 32071 TVAC with TNC connectors

Derating factor

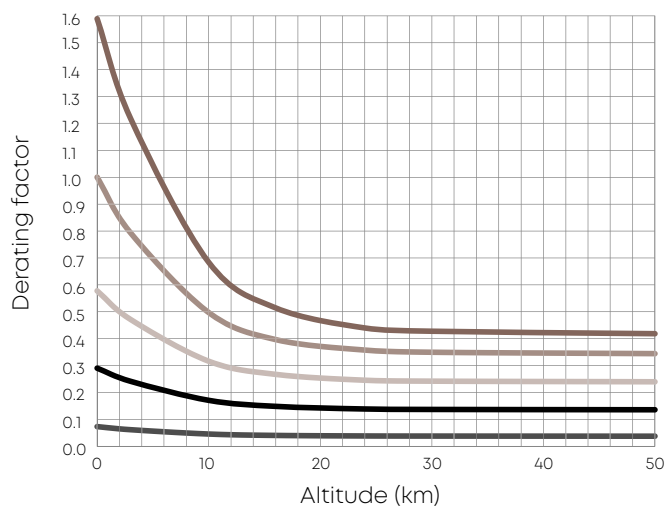

— T = -55 °C — T = 125 °C
 — T = 25 °C — T = 155 °C
 — T = 85 °C

32071 high power cable assemblies



The 32071 cable assembly offers incredible benefits to not only withstand extreme temperature and high altitude conditions, but also provide outstanding performance at high power levels. Based on its Fluoroloy® loaded connectors we can guarantee up to 500 W CW power at 150 °C under vacuum.

In addition, HUBER+SUHNER provides a comprehensive array of Fluoroloy® loaded panel connectors and feed-throughs for high power applications. Fluoroloy® has a higher dielectric constant (as compared to standard Teflon dielectric), but also a higher rate of thermal conductivity. This provides a more effective and efficient transfer of the heat generated at the center conductor, thus increasing the power handling capability of the connector. Fluoroloy® dielectric is available as an option on all of our connector types, should the power levels of the application require it.

32071 – high power, low loss



Product description

Boa-flex II cables utilize a microporous PTFE dielectric for low loss with minimal phase change due to temperature changes and flexure. Typical velocity is 78 % of the speed of light. All offer very low loss and are extremely stable with flexure.

Product features

- Impedance 50 Ω
- Applicable up to 14 GHz
- Low density PTFE for superior electrical performance
- Helical wrapped outer conductor for increased electrical performance
- Exceptional phase and insertion loss stability with flexure
- Excellent phase vs. temperature characteristics
- Preferred for phase matching and tracking applications

Recommended connectors

32071	TNC, N, SC
	Others available

Construction

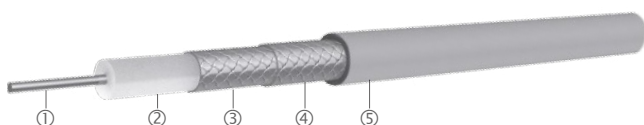

Cable	Inner conductor ①	Dielectric ②	Outer conductor ③	Outer braid ④	Jacket ⑤	Outer diameter
						mm
32071	CuAg solid	PTFE microporous	CuAg tape	CuAg	FEP, translucent amber	9.5

Technical data

Cable	Item no.	Max. operating frequency	Velocity of propagation	Weight	Min. bending radius		Temperature range
					static mm	dynamic mm	
32071	80310956	14 GHz	78 %	208.3 g/m	50.8	152.4	-55 to +200 °C

Available connectors

Connector	Series, pattern	HUBER+SUHNER type	Cable	Operating frequency	Item no.
				GHz	
TNC	straight cable plug	29614-32-71	32071	12.4	80318585
	straight high power cable plug	29614FLPV3-32-71		4.8	80378457
	straight vented cable plug	29614HTPV-32-71		12.4	80378181
N	straight cable plug	29602-32-71		12.4	80318491
	straight cable jack	29601-32-71		12.4	80318466
	straight bulkhead cable jack	29636-32-71		12.4	80340623
SC	straight cable plug	29608-32-71	10.0	80318547	

32071 – graphs

Attenuation (nominal values at +25 °C ambient temperature)

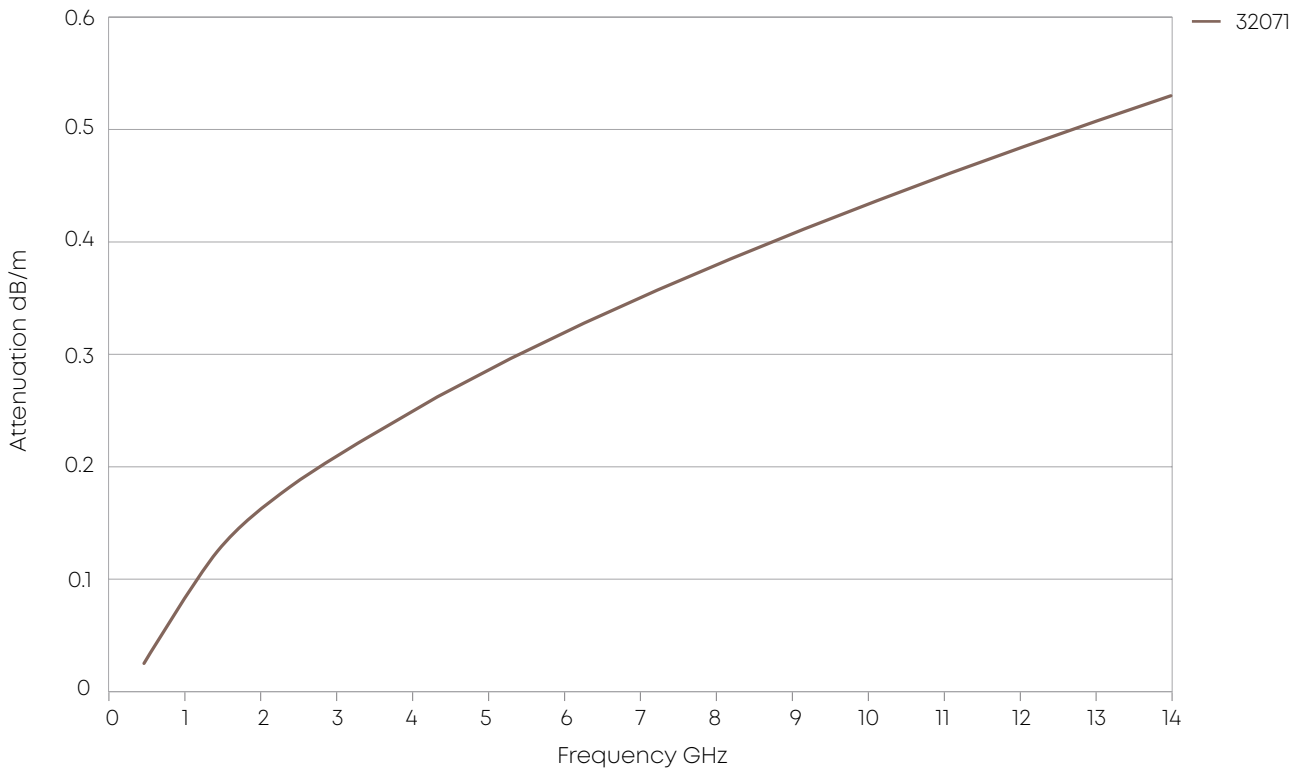

Power handling (maximum values at 25 °C ambient temperature and sea level)

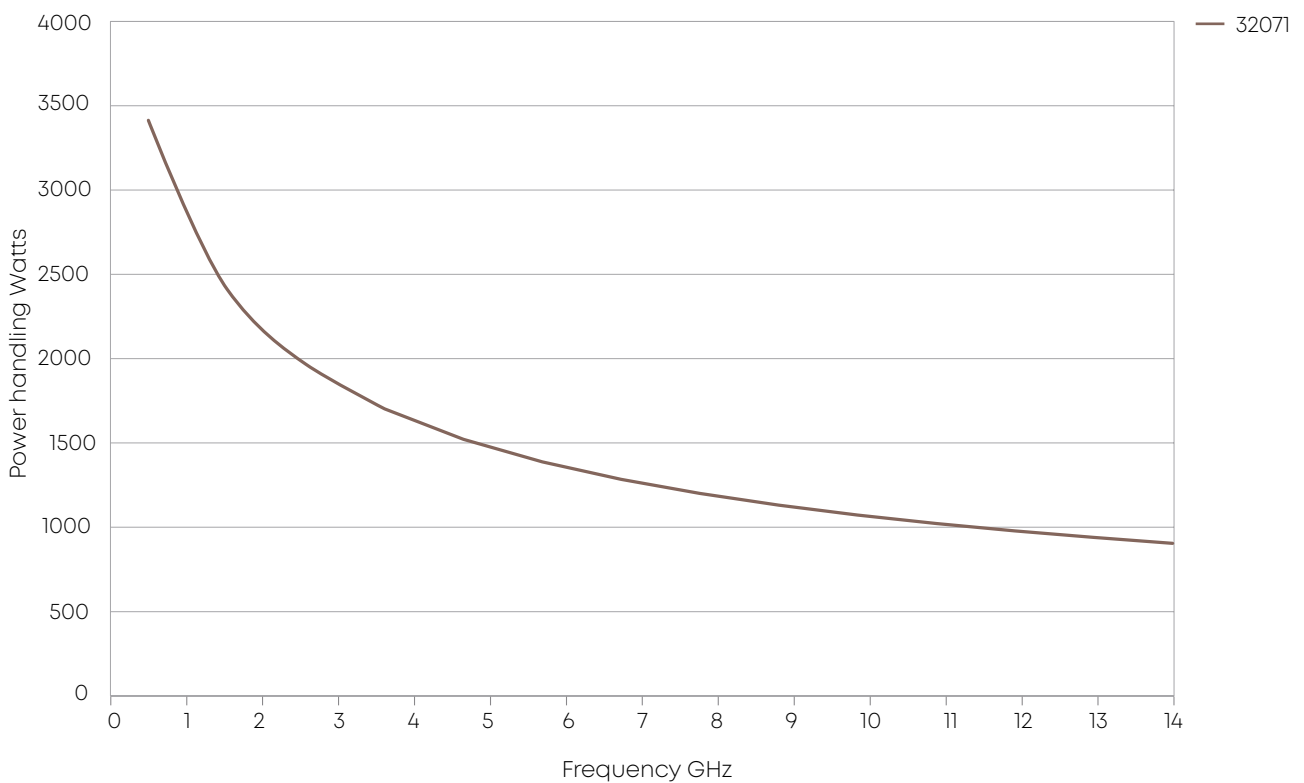

32071 – high power connectors and adaptors

29396G3-ELPV

- Hermetic TNC jack to TNC jack bulkhead adaptor
- Positively vented and pre-potted
- Frequency range up to 10 GHz
- Designed for high power and multipaction-free applications



29713-46ELPV

- Panel mount TNC jack connector
- Integrated heat sink for high power handling capability
- Positively vented and pre-potted
- Frequency range up to 14 GHz
- Designed for high power and multipaction-free applications



Engineering information

General cable design criteria

Microwave transmission lines are used to transmit electromagnetic energy in a controlled manner. In contrast to ordinary circuit theory where resistance (R), capacitance (C), conductance (G) and inductance (L) are represented as lumped constant elements, the R, C, G, and L of microwave transmission lines are considered distributed parameters. Hence, the microwave transmission line is a distributed element circuit. The electrical length of the microwave transmission line is a function of the physical length and the Velocity of Propagation. The principal mode of propagation in a coaxial microwave transmission line is the (TEM) Transverse Electro Magnetic mode. This means that the electromagnetic field has only radial components which include the vector electric field (E) and the vector magnetic field (H). TEM can exist in all transmission lines with two or more conductors or in free space. As the frequency increases, the wavelength will decrease. Therefore, the internal dimensions must be proportionally reduced for mode-free propagation in the TEM mode. If frequency increases and the internal radial dimensions remain constant, the next higher order mode may exist. This second mode in the coaxial line is transverse electric mode TE₁₁. In coaxial microwave transmission lines, the TEM mode propagation is preferred because a second mode may cause resonance. A coaxial line may be used at frequencies that are slightly higher than the theoretical cutoff because the cutoff frequency does not mean that resonance will occur, it only means the possibility of resonance.

One of the first things to consider when selecting or designing a coaxial cable is determining the temperature requirements. The dielectric materials selected for the outer jacket and inner core are some of the limiting factors affecting the allowable temperature range.

Cable style (high flexibility, low flexibility or semi-rigid) should be the next determination. Some applications are able to use any of these styles. Since many flexible cables perform to the level of semi-rigid, and have a similar cost to semi-rigid, then the cost of installation should be considered.

High flexibility cables require a careful selection of materials and construction to ensure a long flex life. For low loss applications, a solid center conductor is -usually preferred. However, a solid center conductor may limit flexibility and is not always the most cost effective for larger diameter cables.

Consider the cost limitations at all times when selecting a cable style or design. Overdesign of a cable may drive the cost unnecessarily high. A lower cost cable may appear to meet the requirements initially, but take care to consider the weaknesses of each individual

style. For example, additional armor can be supplied over most cable assemblies to provide extra protection, however, it is costly.

In conclusion, specific requirements must be carefully considered with regard to the selection of cable and cable assemblies including but not limited to the frequency range, VSWR, insertion loss, mechanical and electrical requirements along with any environmental or application restrictions. A thoughtful and precise review of requirements will result in an optimal design.

Impedance

When "impedance" is mentioned in reference to coaxial cables, the "characteristic impedance" is normally implied. Characteristic impedance (Z_0) is the ratio of voltage to current in a travelling wave. In low loss coaxial cable, the impedance is directly related to the logarithm of the ratio of the inner and outer diameters, and inversely related to the square root of dielectric constant of the core material. In a low loss coaxial cable, the impedance is always a positive real number. Maximum power transfer results only when the characteristic impedance of the transmitter, RF line, and the receiver (or antenna) are equal to each other or the complex conjugate. If the match is exact, losses are only due to the attenuation of the transmission line. If there is a mismatch, reflection losses will result.

$$Z_0 \text{ (ohms)} = \left[138 / \sqrt{\epsilon_r} \right] \times (\log_{10} D/d)$$

d = center conductor diameter in inches

D = dielectric core diameter in inches

Velocity of propagation

Velocity of propagation is the speed of signal transmission relative to the speed of light. Since it is inversely proportional to the square root of the dielectric constant, a lower dielectric constant will result in an increase in velocity. Velocity of propagation is expressed as a percentage of the speed of light in a vacuum and can be calculated by the following formula:

$$V_p \text{ (%) } = \left(1 / \sqrt{\epsilon_r} \right) \times 100$$

Delay

Delay time is defined as the duration between the time a signal enters a coaxial line until it emerges from the other end of a coaxial line. The delay time is essentially independent of frequency and is a function of the dielectric constant and the physical length of the transmission line. Delay time is typically indicated in nanoseconds (10⁻⁹ seconds) per foot.

$$\text{Delay} = T_{ns} = 1.0167 \sqrt{\epsilon_r}$$

Engineering information

Dielectric constant at 3 GHz, 25 °C

Air	1.00
Ceramic steatite	5.70
Glass, borosilicate (Kovar sealing)	4.90
Nylon	2.84
Polyethylene (solid)	2.26
Polyethylene (foamed)	1.20 – 1.55
Polypropylene	2.55
Polystyrene	2.55
Polystyrene, cross-linked	2.58
Polystyrene, foamed 0.25% filler	1.03
Polytetrafluoroethylene (solid teflon)	2.03
Polytetrafluoroethylene (low density)	1.2 – 1.60
Porcelain	5.04
Rubber, butyl	2.35
Rubber, neoprene	4.00
Rubber, silicone	3.13
Fluoroloy H	2.43
9010 corning glass	6.3
9013 corning glass	6.65
Noryl	2.55
K-50	2.60
Ultem	3.05

1. Number of shields: flat braid, round braid and helical wrap
2. Braid style and coverage: a flat braid is usually better than a round braid and a higher percentage of braid coverage normally provides better shielding.
3. Thickness of shield materials and plating of the conductor: cable outer conductors are typically silver plated.
4. Connector and style of attachment: the best shielded connector typically uses a threaded coupling nut with a slotless outer conductor attached to the cable by clamping, soldering or crimping with minimal amount of outer conductor junctions.

Capacitance

Capacitance is the property which permits electrical energy to be stored in a dielectric between two conductors that are at different potentials. Similar to impedance, capacitance is dependent upon the inner and outer conductor dimensional ratio and the dielectric constant, but in a reciprocal way. For example, in cables with the same dielectric constant, if capacitance decreases then impedance increases. The capacitance of a cable is expressed in picofarads (10-12 farad) per foot, and can be calculated with the following formula:

$$C_{pf/ft} = 7.354 \epsilon_r / \log_{10} (D/d)$$

Shielding

The shielding effectiveness of a coaxial cable depends on the construction of its outer conductors. Generally, the shielding efficiency is measured by the relative level of the signal leaking from the outer conductor in decibels per one foot of the length. The effectiveness of shielding on microwave cables usually diminishes with increased frequency. In practice, the shielding efficiency of semi-rigid (solid sheath) cables is limited by the leakage of the connectors and the cable/connector junction. Some factors which influence the shielding effectiveness of flexible cable assemblies are:

Engineering information

VSWR/return loss conversion

Reflection can be estimated by reflection coefficient, which is the ratio of reflected wave voltage (current) to incident wave voltage (current). Reflection coefficient has a magnitude and phase and can be represented by complex numbers. Another parameter for reflection is voltage standing wave ratio (VSWR). VSWR is defined from the magnitude of reflection coefficient and, therefore, does not have a phase. Return loss compares the power in the reflected wave with that in the forward wave. The unit for return loss is decibel. Return loss can be calculated from VSWR and vice-versa.

VSWR to return loss

VSWR	Reflection coefficient	Return loss dB
1.01	0.0050	46.06
1.02	0.0099	40.09
1.03	0.0148	36.61
1.04	0.0196	34.15
1.05	0.0244	32.26
1.06	0.0291	30.71
1.07	0.0338	29.42
1.08	0.0385	28.30
1.09	0.0431	27.72
1.10	0.0476	26.44
1.11	0.0521	25.66
1.12	0.0566	24.94
1.13	0.0610	24.29
1.14	0.0654	23.69
1.15	0.0698	23.13
1.16	0.0741	22.61
1.17	0.0783	22.12
1.18	0.0826	21.66
1.19	0.0868	21.23
1.20	0.0909	20.83
1.21	0.0950	20.44
1.22	0.0991	20.08
1.23	0.1031	19.73
1.24	0.1071	19.40
1.25	0.1111	19.08
1.26	0.1150	18.78
1.27	0.1189	18.49
1.28	0.1228	18.22
1.29	0.1266	17.95
1.30	0.1304	17.69

Return loss dB	Reflection coefficient	VSWR
40	0.0100	1.020
39	0.0112	1.023
38	0.0126	1.026
37	0.0141	1.029
36	0.0158	1.032
35	0.0178	1.036
34	0.0200	1.041
33	0.0244	1.046
32	0.0251	1.052
31	0.0282	1.058
30	0.0316	1.065
29	0.0355	1.074
28	0.0398	1.083
27	0.0447	1.094
26	0.0501	1.106
25	0.0562	1.119
24	0.0631	1.135
23	0.0708	1.152
22	0.0794	1.173
21	0.0891	1.196
20	0.1000	1.222
19	0.1122	1.253
18	0.1259	1.288
17	0.1413	1.329
16	0.1585	1.377
15	0.1778	1.433
14	0.1995	1.499
13	0.2239	1.577
12	0.2512	1.671
11	0.2818	1.785

Power handling of RF coaxial assemblies

Two potential failure modes must be considered when determining the power handling capability of an RF coaxial cable:

- Peak power (voltage breakdown)
- Average or CW power

The peak power (voltage breakdown) occurs when the voltage gradient between the cable center conductor exceeds a limiting value causing the signal to arc across the path of the least resistance. Generally, the path of the least resistance is located at the cable/connection junction. Catastrophic breakdown is not the only problem: the existence of corona, usually around the center conductor, produces other deleterious effects. Corona cutting is a concern with PTFE insulators whereupon the PTFE is eroded causing the formation of cavities (usually without carbonisation).

Coaxial cable assemblies are typically rated with the peak power handling much lower than what the interface can handle. To maximise peak power of the cable assembly, a high voltage (HV) connector should be used. A higher voltage potential is achieved by overlapping the dielectric thereby increasing the airline arc path. A drawback to this design is that connectors which are modified in this way generally have greater VSWR at higher frequencies.

If the transmission line has reflections, the voltage and the current along the line will have maximums and minimums. The cause of this nonuniform distribution is superposition of the incident and reflected waves. Breakdown is a function of the maximum voltage. Higher reflection results in lower voltage handling. Even high-performance assemblies with low VSWR can have poor peak power handling if they are connected to an unmatched load. Peak power handling is dependent on frequency since the typical value of VSWR is proportional to the increase in frequency. The most common breakdown at high altitudes (usually greater than 70 000 ft) is ionisation breakdown in the air path. For vacuum and space applications, the main type of breakdown is multipaction breakdown. For average power rating of a cable with a pulsed signal, multiply the peak power rating by the duty cycle.

Frequency range, ambient temperature, altitude, physical size, and the thermal properties of each layer of construction are the primary factors which determine the average power handling capability of an RF coaxial cable. The average power failure occurs when the level of power transmitted results in resistive

Engineering information

and dielectric heating at a rate higher than the rate at which the heat can be conducted away through the different layers of cable and dissipated from the outermost cable layer to the environment. A buildup of heat energy causes the internal cable temperature to exceed the maximum rated dielectric temperature. Convection, conduction and radiation are methods to remove heat from the cable assembly. Conduction transfer of heat through the outer and inner conductors of a cable is particularly effective for short assemblies. For very high altitudes and space applications, the air is too thin or nonexistent and convection cooling is ineffective. Heat from the cable assembly can only be removed by radiant heat and conduction.

HUBER+SUHNER has developed a unique computer-modeling program that accurately predicts the power rating for coaxial cables of varying designs and materials. Power handling is calculated for convection cooling only. Conduction and radiation are included in the safety margins. These charts provide the CW or average power rating for all cables versus frequency. The following calculation shows how to use the CW power charts for non-standard temperature conditions:

Where:

- P = power at temp, t1 and altitude a1
- Ft = temperature derating factor at temp. t1
- Fa = altitude derating factor at altitude a1
- Pf = power level at frequency f1

Example:

What is the average power rating for HUBER+SUHNER 32051 cable at 12 GHz at an ambient temperature of 100 °C and an altitude of 30 000 ft?

- Pf = 580 Watts (see data – page 122)
- Ft = 0.58 (see chart)
- Fa = 0.68 (see chart)

Therefore:

$$P = 580 (0.58)(0.68) = 229 \text{ Watts}$$

Altitude derating factor for RF power

Altitude ft	fa avg	fa peak
Sea level	1	1
10 000	0.90	0.5
20 000	0.79	0.2
30 000	0.68	0.14
40 000	0.58	0.10
50 000	0.48	0.08
60 000	0.38	0.06
70 000	0.29	0.05

Temperature derating factor for RF average power

Ambient °C	ft
25°	1
50°	0.83
85°	0.66
100°	0.58
125°	0.43
150°	0.28
200°	0.15

Note: Derating factors are calculated for convection only.

Multipactor and ionisation breakdown

Multipactor breakdown is a failure mode of an RF component that only occurs under conditions of high vacuum, where a certain frequency distance product condition exists between the inner and outer conductors and where a sufficiently large RF electric field strength exists. In a high vacuum environment, an electron may have a free path longer than the electrode separation distance. When this electron collides with the electrode it may release secondary electrons. If both frequency and the distance between inner and outer conductor are favorable, the secondary electrons will be accelerated by the electromagnetic field. Large electron densities rapidly build up and breakdown results. At very low and very high frequencies multipactor breakdown is impossible. Multipactor breakdown can also occur between the conductor and the insulator. A multipactor discharge itself adsorbs little power, but once initiated it can cause increased outgassing from materials within components, which may lead to a gas discharge and total failure. To prevent this event, the microwave components should have vent holes of sufficient size to allow the gasses to escape at a known rate. Multipactor breakdown also results in increased heating within the cable or connector, noise generation, harmonic distortion and intermodulation (when multiple frequency RF signals are applied).

For every vacuum application the power handling should be calculated individually. The worst frequencies for multipactor breakdown are between 500 MHz and 2.5 GHz. At low voltage levels (less than 20 V) and low average power (less than 8 W), multipactor breakdown is theoretically impossible.

In ionisation breakdown, secondary electrons are produced through collisions between electrons and gas molecules. Ionisation breakdown occurs at pressures higher than those for multipactor. Like multipactor breakdown, ionisation breakdown is not possible at very low and very high frequencies and low power levels.

Engineering information

However, ionisation breakdown is considerably more complex than multipactor breakdown because of the additional dependence on pressure and the type of gas (if other than air).

HUBER+SUHNER has designed, manufactured and delivered several high performance cable assemblies for use in high power, high altitude and space environments. These products were tested by an independent laboratory to determine if any failures due to ionisation and/or multipactor breakdown would occur.

Connector power handling

The primary factor restricting power handling in the coaxial adaptor or connector is overheating due to restricted heat dissipation. High power cable assemblies, in general, should not exceed 200 °C, however dielectric materials used in precision connector interfaces like 7 mm and 3.5 mm are only rated to 90 °C. HUBER+SUHNER manufactures a high temperature precision bead for high power applications. The maximum temperature usually occurs on the connector inner conductor. When connectors are employed in a coaxial cable assembly, the connector should have a center conductor diameter that is equal to or larger than the cable center conductor diameter in order to maximize the power handling of the assembly.

Although many applications support the use of standard connectors and coaxial transmission lines, recent designs in TWT's, high power filters and high power test equipment have placed a great burden on standard coaxial cable assemblies. Since the internal configuration of the connector termination is a major contributor to heat buildup, HUBER+SUHNER employs a unique dielectric material known as Fluoroloy H® inside connectors used for high power applications. This material has a slightly higher dielectric constant (compared to standard Teflon® dielectric) but has a higher rate of thermal conductivity which allows the heat that is generated in the center conductor to transfer to the outer conductor more rapidly, thus increasing the power handling capability of the connector or adaptor. The majority of HUBER+SUHNER connectors and adaptors can be produced with Fluoroloy H® dielectric upon request. In addition, HUBER+SUHNER can design special customised high power interfaces that are mechanically and electrically compatible with standard interfaces. Contact HUBER+SUHNER sales department regarding any high power requirements.

Note: Teflon® is a trademark of Dupont; Fluoroloy H® is a registered trademark of Saint Gobain Corp.

Power conversion chart

dBm	mW	dBm	mW	dBm	mW	dBm	mW	dBm	W	dBm	W
-20	0.010	-6	0.250	+8	6.30	+22	159	+36	3.91	+50	100
-19	0.012	-5	0.316	+9	7.94	+23	200	+37	5.01	+51	126
-18	0.016	-4	0.398	+10	10.0	+24	251	+38	6.31	+52	158
-17	0.020	-3	0.501	+11	12.6	+25	316	+39	7.94	+53	200
-16	0.025	-2	0.630	+12	15.8	+26	398	+40	10.0	+54	251
-15	0.032	-1	0.794	+13	19.9	+27	501	+41	12.6	+55	316
-14	0.040	0	1.00	+14	25.1	+28	631	+42	15.8	+56	398
-13	0.050	+1	1.25	+15	31.6	+29	794	+43	20.0	+57	501
-12	0.063	+2	1.58	+16	39.8	+30	1000	+44	25.1	+58	631
-11	0.079	+3	2.00	+17	50.1	+31	1260	+45	31.6	+59	794
-10	0.100	+4	2.51	+18	63.1	+32	1590	+46	39.8	+60	1000
-9	0.130	+5	3.16	+19	79.4	+33	2000	+47	50.1	+63	2000
-8	0.160	+6	3.98	+20	100	+34	2550	+48	63.1	+66	4000
-7	0.200	+7	5.01	+21	120	+35	3160	+49	79.4	+70	10000

Engineering information

Intermodulation distortion in passive components

Intermodulation distortion in passive microwave components is caused by internal nonlinearities. In a truly linear system, the output is directly proportional to the input.

In a nonlinear system, the output signal is distorted by changes in the amplitude of the input signal. Intermodulation distortion creates new output signals from the nonlinear combinations of two or more input signals mixed together. A nonlinear circuit will create an infinite number of harmonics from two fundamental frequencies (f_1 and f_2). A particular concern for telecommunication systems engineers is the intermodulation product of the third order (such as $2f_1 - f_2$ and $2f_2 - f_1$), especially if f_1 and f_2 are closely spaced. With certain system designs and bandwidth allocations, the third order intermodulation products can be generated at the same frequencies as the receive channels of the system. In general, intermodulation products increase system noise and reduce the number of available channels.

Intermodulation distortion is most pronounced in systems where the high power transmission and low power receiver signals are carried simultaneously in the same transmission line, such as in the cable between the duplexer and the antenna in GSM base stations and in certain space applications. For low power levels, the effects of intermodulation distortion are significantly less. HUBER+SUHNER is involved in the research of the intermodulation problem as a participant in the IEC TC46 WG6 passive intermodulation working group.

Coaxial cable assemblies have often been viewed as linear components. However, pure linear components do not exist. There are small nonlinearities in the connectors and in the cable to connector junctions. Intermodulation distortion in connectors is usually caused by thin surface oxide layers at the connector junctions or by insufficient contact pressure when the current-carrying contact zones become separated. Separation is usually microscopic and can be caused by either electron tunneling or microscopic arcing. The presence of ferromagnetic materials in the current path may also contribute to intermodulation distortion.

Some simple design rules can help avoid intermodulation distortions in coaxial cable assemblies:

- Use of semi-rigid cable with a seamless outer conductor in place of flexible cable.
- Use of a solid center conductor in place of a stranded center conductor.
- Directly attach the outer conductor to the connector body by soldering or clamping in lieu of crimping.
- Limit the number of parts in the current path.
- Eliminate contaminants in the current path.
- Use high quality machining in the connector parts with a smooth surface finish.
- Avoid contaminants in the plating solutions.
- Ensure adequate and uniform plating thickness.
- Avoid use of magnetic materials in the current-carrying path.
- Ensure adequate contact pressure.
- Contact surface of female contact fingers should cover as close to 360 as possible (i. e. narrow slots or slotless).
- Use connector interfaces with radial dimensions as large as possible (7/16 over N, N over SMA).

Space applications

Every space application is unique and requires careful consideration before selecting the components to be used. A space environment subjects components and assemblies to severe environmental stress:

- Low earth orbit spacecraft subject solder joints, welds, brazements and mechanical connections to continuous hot/cold thermal cycling every 90 minutes. The manufacturing process must be carefully controlled per NASA STD-8739 requirements to assure consistent, reliable connections and assemblies. Solder connections must be 100 % X-rayed to assure their integrity and reliability.
- There is no atmosphere so convection cooling does not occur. Excess heat must be removed by radiation, which requires the surface of the connectors to be an infrared emitter, or by conduction which requires a secondary heat sink.
- Certain materials „outgas“ in the extreme vacuum of space which requires the designer to select materials and components that meet NASA requirements for Total Mass Loss (TML) and Collected Volatile Condensable Material (CVCM) to avoid contamination of optics and other sensitive equipment on board the spacecraft.
- Materials must be carefully chosen so that ionising radiation does not destroy the connector or cable dielectric or the cable jacket.
- Multipaction failure (described in more detail herein) is a concern for high power applications.
- Intermodulation distortion (described in more detail herein) is a concern within systems where high power transmitting and low power receiving signals need to be carried simultaneously in the same transmission line.
- The manufacturing environment must be carefully controlled and the packaging materials selected to prevent dust and particles from accumulating on the components and subsequently contaminating the spacecraft.

Engineering information

Processes and controls used by HUBER+SUHNER for procurement, manufacture, assembly, soldering, X-ray, inspection and testing have been certified by NASA for use in spacecraft applications. HUBER+SUHNER has the design, manufacturing, testing and applications experience and expertise to supply your needs for passive microwave devices for use in any space environment.

Phase stability with flexure

Phase stability vs. flexure is a measure of the phase change of a cable as a result of flexing. The manner of flexure will affect insertion phase. Reducing the bend radius or increasing the bend angle will increase the phase change. Similarly, as the number of flexures increases the phase change will increase. Increasing the ratio of cable diameter to bend diameter will decrease the phase changes. Phase changes over frequency can be considered a linear response, although with some cables change can be more significant at higher frequencies. A microporous dielectric cable will typically have better phase stability than a solid dielectric.

Phase stability vs. temperature

Phase stability vs. temperature is a measure of the signal speed variation when the cable is exposed to different temperatures. The values are specified in parts per million (ppm) or in degrees per gigahertz and meters (deg/(GHz*m)). They usually refer to the difference between maximum and minimum values in a certain temperature range. They can be converted to each other using the following formula:

$$\Delta\varphi \text{ [deg/GHz/m]} * \frac{832.76 \text{ GHz*m/deg}}{\sqrt{\epsilon_r}} = \Delta\varphi \text{ [ppm]}$$

$$\Delta\varphi \text{ [ppm]} * \frac{\sqrt{\epsilon_r}}{832.76 \text{ GHz * m/deg}} = \Delta\varphi \text{ [deg/GHz/m]}$$

For frequencies in the low single-digit GHz range, the phase change is not proportional to the frequency anymore but for higher frequencies it is.

Main influences are the materials used and the construction of the cable. Most cables have different behaviors depending on the temperature range considered. There are sections with a linear or a non-linear behavior. Linear behavior show the influence of the regular length and volume expansion of the cable components. Non-linear sections originated from phase changes in materials or special mutual reactions between single elements of the cable. An example for a phase changes in materials is the devitrification of PTFE at 20 °C. At this temperature the crystal structure changes from triclinic to hexagonal. This leads to a rapid change of phase, the so called „Teflon® knee“.

Phase tracking

Phase tracking is the ability of multiple assemblies to closely reproduce their phase relative to each other over a range of temperature, flexure or both. Phase tracking is essentially a measure of the assemblies' mechanical repeatability and consistency. Thermal conditioning of coaxial cable enhances tracking characteristics.

Phase matching

Phase matching is a term generally used to describe two or more cable assemblies with the same phase length. A more precise term is electrical length matching since phase measurements are from 0 ° to 360 ° of phase, with repeating cycles of 360 ° phase. The mechanical lengths of phase matched cable may not always be equal due to slight variations in the cable velocity of propagation. There are two distinctly different versions of phase matching: 1) absolute phase matched cables are matched to a predetermined phase value, and 2) relative phase matched cables are matched to each other. In either case, the tolerance of phase matching is frequency dependent although cable length and type may effect the matching capabilities.

Engineering information

Phase matching of cable assemblies

Definition

The term "phase matching" refers to the relative electrical length of an assembly compared with a reference cable or a given electrical length.

Absolute length

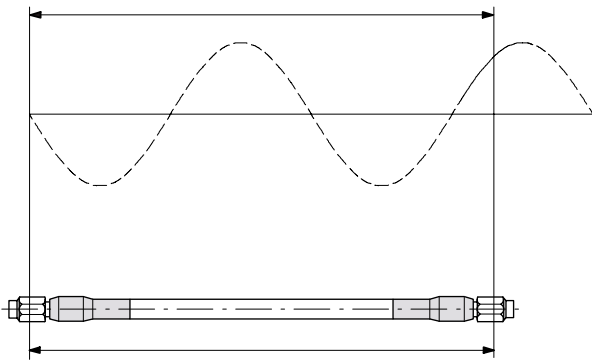

Relative length

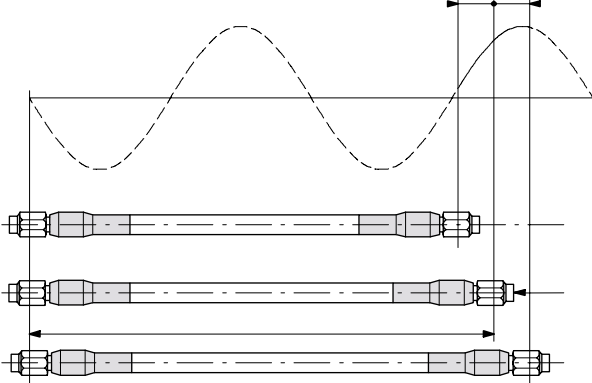

Guarantee of phase matching

HUBER+SUHNER guarantees phase matching ex-factory. The relevant measurement logs are included in the supply. It is essential during installation and service to ensure that all assemblies of a phase matched set are exposed to the identical thermal and mechanical stresses.

Reference cables

Usually, a reference cable is produced for each phase matched assembly set when an initial production run takes place. The absolute electrical length measured is internally saved. The reference cables are stored during 10 to 20 years under controlled conditions (temperature, humidity) together with the order data to allow individual assemblies to be replaced whenever the need arises.

Attenuation (insertion loss)

Attenuation is a measure of the ability of a component to carry an RF signal efficiently. Coaxial cable loss is the sum of the dielectric and conductor losses and is a function of the materials used to manufacture the cable. Attenuation stability with flexure will have similar response characteristics as „phase vs. flexure“ described previously, as will the „tracking“ characteristics. Attenuation matching will not be as dependent upon the dielectric style, although for long lengths the insertion loss stability vs. flexure is critical.

$$A_i \left(\frac{dB}{100 ft} \right) = \frac{0.435 \sqrt{F}}{Z_0 \times d}$$

Inner conductor loss (where F is the frequency in MHz)

$$A_o \left(\frac{dB}{100 ft} \right) = \frac{0.435 \sqrt{F}}{Z_0 \times D}$$

Outer conductor loss

$$A_d \left(\frac{dB}{100 ft} \right) = 2.78 \rho \sqrt{\epsilon_r} \times F$$

Dielectric loss Where: ρ = power factor (loss tangent)
 $\rho = 0.00016$ ($\epsilon_r = 2.1$)
 $\rho = 0.00005$ ($\epsilon_r = 1.6$)

$$A = A_i + A_o + A_d$$

Engineering information

Abbreviations

Al	aluminium
AlCuAg	silver plated copper clad aluminium
CuAg	silver plated copper
CuSn	tin plated copper
ECTFE	ethylen-chlortrifluorethylen
ETFE	ethylene-tetrafluoroethylene
FEP	fluorinated ethylene propylene
LD-PTFE	low density PTFE
LSFH	low smoke free of halogen
MIL	hexagonal nut with safety holes
ML	mounting hole
PE	polyethylene
PTFE	polytetrafluorethen
PUR	polyurethane
QL	quick lock
Sn soaked Cu braid	tin soaked copper braid
SPE	foamed polyethylene
StCu	copper clad steel
StCuAg	silver plater copper clad steel
TP	tin plated
TP_M17	tin plated, MIL-C-17_QPL
ULD-PTFE	ultra low density PTFE

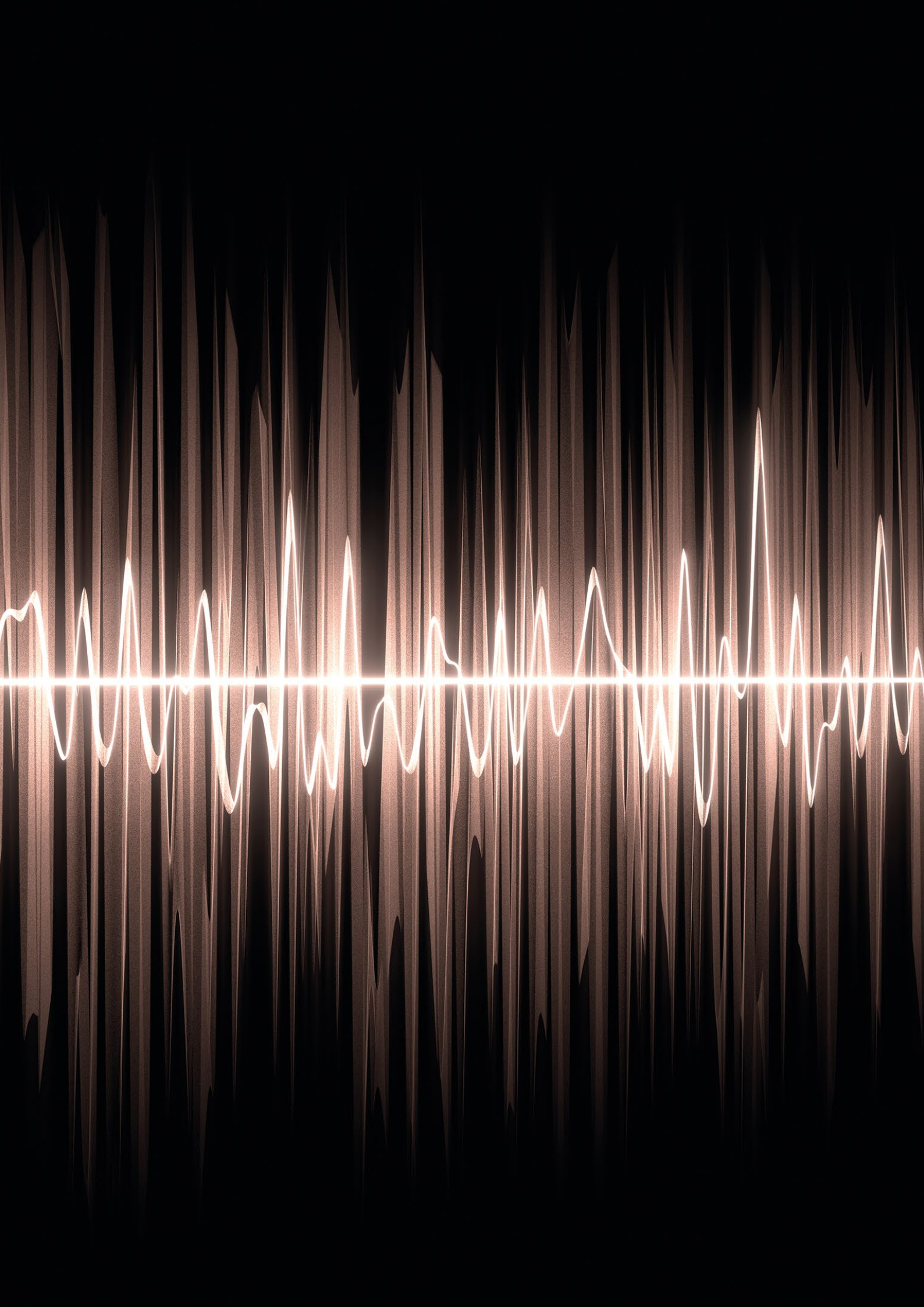

Selection guide – quick assembly selection matrix

Cable type	Outer diameter (mm)	Frequency range (GHz)	VOP (%)	nom. cable attenuation (dB/m @ 18 GHz)	nom. cable attenuation (dB/m @ 26.5 GHz)	nom. cable attenuation (dB/m @ 40 GHz)	nom. cable attenuation (dB/m @ 50 GHz)	nom. cable attenuation (dB/m @ 67 GHz)	nom. cable attenuation (dB/m @ 110 GHz)	CW power @ 1 GHz sea level / 25 °C	CW Power @ 18 GHz sea level / 25 °C	Min. temperature (°C)	Max. temperature (°C)	Min. bending radius (static) (mm)	Weight (g/m)
SUCOFLEX 101	3.7	26.5	77	1.98	2.46					337	80	-55	125	11	36
SUCOFLEX 101 E	3.7	26.5	77	1.98	2.46					228	54	-40	85	11	33
SUCOFLEX 102	4.0	40	77	1.70	2.10	2.62				448	106	-55	125	12	40
SUCOFLEX 102 E	4.0	40	77	1.70	2.10	2.62				273	64	-40	85	12	37
SUCOFLEX 102 D	4.5	40	77	1.70	2.10	2.62				448	106	-55	125	15	45
SUCOFLEX 103	4.6	33	77	1.33	1.65					700	165	-55	125	13	53
SUCOFLEX 103 E	4.6	33	77	1.33	1.65					410	97	-40	85	13	52
SUCOFLEX 103 D	5.1	33	77	1.33	1.65					700	165	-55	125	20	63
SUCOFLEX 103 EA	10.3	33	77	1.33	1.65					369	87	-40	85	30	142
SUCOFLEX 104	5.5	18	77	1.10						1032	243	-55	125	16	73
SUCOFLEX 104 E	5.5	18	77	1.10						683	161	-40	85	16	65
SUCOFLEX 104 D	6.1	18	77	1.10						1032	243	-55	125	20	96
SUCOFLEX 104 I	6.6	18	77	1.10						683	161	-40	85	16	82
SUCOFLEX 126	5.5	18	77	1.10						1032	243	-55	125	16	70
SUCOFLEX 126 E	5.5	18	77	1.10						683	161	-40	85	16	66
SUCOFLEX 126 D	6.1	18	77	1.10						1032	243	-55	125	20	80
SUCOFLEX 126 EA	10.3	18	77	1.10						614	144	-40	85	30	171
SUCOFLEX 106	7.9	18	77	0.76						1812	427	-55	125	24	145
SUCOFLEX 106 D	8.3	18	77	0.76						1812	427	-55	125	26	157
SUCOFLEX 106 I	8.2	18	77	0.76						1058	249	-40	85	24	146
SUCOFLEX 106 A	13.2	18	77	0.76						1000	235	-40	85	50	224
SUCOFLEX 118	7.9	18	77	0.76						1812	427	-55	125	24	145
SUCOFLEX 118 D	8.3	18	77	0.76						1812	427	-55	125	26	157
SUCOFLEX 118 I	8.2	18	77	0.76						1058	249	-40	85	24	146
SUCOFLEX 118 A	13.2	18	77	0.76						1000	235	-40	85	50	224
SUCOFLEX 304 Space	5.4	18	77	0.76						1032	243	-55	150	20	46
SUCOFLEX 307 Space	9.0	8	77	1.20						1821	n/a	-55	150	50	133
SUCOFLEX 526	5.5	26.5	77	1.10	1.37					1032	243	-55	125	16	70
SUCOFLEX 526 E	5.5	26.5	77	1.10	1.37					683	161	-40	85	16	66
SUCOFLEX 526 EA	10.3	26.5	77	1.10	1.37					614	144	-40	85	30	171
SUCOFLEX 526 S	7.7	26.5	77	1.10	1.37					1032	243	-55	125	25.4	144
SUCOFLEX 526 V	13.0	26.5	80	2.68	3.38					150	35	15	30	50	275
SUCOFLEX 540	4.0	40	77	1.70	2.10	2.62				448	106	-55	125	12	40
SUCOFLEX 540 E	4.0	40	77	1.70	2.10	2.62				273	64	-40	85	12	37
SUCOFLEX 540 EA	7.7	40	77	1.70	2.10	2.62				245	58	-40	85	20	120
SUCOFLEX 540 S	6.4	40	77	1.70	2.10	2.62				448	106	-55	125	25.4	95

Cable type	Recommended for dynamic applications	Qualified acc. to MIL standards	High crush resistant, armoured	Excellent phase stability vs. Bending	Excellent phase stability vs. Temperature	Cable assembly only	Stock assemblies available	RF test lead	PIM test lead	Field terminable	High flexlife	Handformable	Form-stable	Halogen-free	Flame retardant, halogen-free	Low profile connectors (bent to the end)	More information see page
SUCOFLEX 101		•		•		•											16
SUCOFLEX 101 E				•		•					•						16
SUCOFLEX 102		•		•		•											22
SUCOFLEX 102 E				•		•					•						22
SUCOFLEX 102 D		•	•	•		•											22
SUCOFLEX 103		•				•											26
SUCOFLEX 103 E						•					•						26
SUCOFLEX 103 D		•	•			•											26
SUCOFLEX 103 EA			•			•											26
SUCOFLEX 104		•				•											30
SUCOFLEX 104 E						•					•						30
SUCOFLEX 104 D		•	•			•											30
SUCOFLEX 104 I						•											30
SUCOFLEX 126	•	•		•		•											34
SUCOFLEX 126 E	•			•		•					•						34
SUCOFLEX 126 D	•	•	•	•		•											34
SUCOFLEX 126 EA	•		•	•		•					•						34
SUCOFLEX 106		•				•											38
SUCOFLEX 106 D		•	•			•											38
SUCOFLEX 106 I						•											38
SUCOFLEX 106 A			•			•											38
SUCOFLEX 118	•	•		•		•											38
SUCOFLEX 118 D	•	•	•	•		•											38
SUCOFLEX 118 I	•			•		•											38
SUCOFLEX 118 A	•		•	•		•											38
SUCOFLEX 304 Space		•				•											43
SUCOFLEX 307 Space		•				•											46
SUCOFLEX 526	•			•		•		•									52
SUCOFLEX 526 E	•			•		•	•	•			•						52
SUCOFLEX 526 EA	•		•	•		•		•			•						52
SUCOFLEX 526 S	•		•	•		•	•	•									52
SUCOFLEX 526 V	•		•	•	•	•	•	•									52
SUCOFLEX 540	•			•		•		•									53
SUCOFLEX 540 E	•			•		•	•	•			•						53
SUCOFLEX 540 EA	•		•	•		•		•			•						53
SUCOFLEX 540 S	•		•	•		•	•	•									53

Selection guide – quick assembly selection matrix

Cable type	Outer diameter (mm)	Frequency range (GHz)	VOP (%)	nom. cable attenuation (dB/m @ 18 GHz)	nom. cable attenuation (dB/m @ 26.5 GHz)	nom. cable attenuation (dB/m @ 40 GHz)	nom. cable attenuation (dB/m @ 50 GHz)	nom. cable attenuation (dB/m @ 67 GHz)	nom. cable attenuation (dB/m @ 110 GHz)	nom. cable attenuation (dB/m @ 145 GHz)	CW power @ 1 GHz sea level / 25 °C	CW Power @ 18 GHz sea level / 25 °C	Min. temperature (°C)	Max. temperature (°C)	Min. bending radius (static) (mm)	Weight (g/m)
SUCOFLEX 550	3.7	50	77	1.98	2.46	3.09	3.51				337	80	-55	125	11	36
SUCOFLEX 550 E	3.7	50	77	1.98	2.46	3.09	3.51				228	54	-40	85	11	33
SUCOFLEX 550 EA	7.7	50	77	1.98	2.46	3.09	3.51				205	48	-40	85	20	114
SUCOFLEX 550 S	6.1	50	77	1.98	2.46	3.09	3.51				337	80	-55	125	25.4	78
SUCOFLEX 570	3.3	70	77	2.90	3.56	4.45	5.03	5.91			194	46	-55	125	11	25
SUCOFLEX 570 E	3.3	70	77	2.90	3.56	4.45	5.03	5.91			131	31	-40	85	11	20
SUCOFLEX 570 S	5.8	70	77	2.90	3.56	4.45	5.03	5.91			194	46	-55	125	25.4	76
SUCOFLIGHT 123	5.84	18	77	1.06							1228	246	-55	200	22.9	68
SUCOFLIGHT 134	8.64	18	80	0.70							1969	394	-55	200	48.3	143
MINIBEND	2.50	65	70.3	3.41	4.23	5.36	6.10				173	41	-55	125	5.08	14.9
MINIBEND L	2.64	50	76	2.70	3.30	4.10	4.61				288	68	-55	125	5.08	16.4
MICROBEND	1.96	90	70.3	4.67	5.76	7.23	8.2	9.67			111	26	-55	125	1.5	11.9
MICROBEND L	2.00	85	76	3.54	4.33	5.36	6.03	7.03			111.8	26.1	-55	200	5.08	10.42
MINI 141	3.66	40	76.3	1.70	2.09	2.61					590	139	-55	125	8.4	31.3
NANOBEND	1.62	110	70	6.58	8.07	10.07	11.36	13.33	17.56		79.1	18.8	-55	200	5.08	7.44
MINI250H	5.72	26	77	1.10							590.6	123.9	-55	200	16.76	81.85
SUCOTEST 145	4.3	145	76	10.25	11.87	14	15.36	17.42	21.75	24.71	42	3	-40	85	25.4	20
SUCOTEST 110	4.3	110	70	7.28	8.70	10.70	12.00	14.00	18.00		30	20	-40	85	25.4	20
SUCOTEST 18	4.6	18	77	1.33							555	131	-55	105	13	53
SUCOTEST 18A	10.3	18	77	1.10							512	121	-40	85	30	171
TL-8A	10.3	8	82								150	n/a	-5	85	110	150
TL-P	1.3	4	70								560	n/a	-15	65	50	150
MULTIFLEX 86	2.65	40	71	3.55	4.46	5.69					159	37	-65	165	6	21
MULTIFLEX 86_HE	2.65	67	71	3.56	4.57	5.69	6.52	7.81			159	37	-65	165	6	21
MULTIFLEX 141	4.14	33	71	2.09	2.67						320	66	-65	165	10	45
S 04272 B	5.5	18	82	1.64							137	32	-40	85	25	44
S 04212 B	5.5	18	82	1.64							137	32	-40	85	25	41
S 04262 B-01	5.5	18	82	1.64							137	32	-40	85	25	41
MULTIFLEX 53-02	1.74	100	70	5.19	6.46	8.17	9.30	11.05			34	8	-65	165	1.5	10
32071 (BOA_FLEX II)	9.5	14	77.8								3413	n/a	-55	200	50.8	208.3
EACON 2C	4.0	18	77	1.70							448	106	-55	200	12	37
EACON 4C	5.5	18	77	1.10							1032	243	-55	200	16	73
EACON 6C	7.9	18	77	0.76							1812	427	-55	200	24	145

Cable type	Recommended for dynamic applications	Qualified acc. to MIL standards	High crush resistant, armoured	Excellent phase stability vs. Bending	Excellent phase stability vs. Temperature	Cable assembly only	Stock assemblies available	RF test lead	PIM test lead	Field terminable	High flexlife	Handformable	Form-stable	Halogen-free	Flame retardant, halogen-free	Low profile connectors (bent to the end)	More information see page
SUCOFLEX 550	•			•		•		•									54
SUCOFLEX 550 E	•			•		•	•	•			•						54
SUCOFLEX 550 EA	•		•	•		•		•			•						54
SUCOFLEX 550 S	•		•	•		•	•	•									54
SUCOFLEX 570	•			•		•		•									56
SUCOFLEX 570 E	•			•		•	•	•			•						56
SUCOFLEX 570 S	•		•	•		•	•	•									56
SUCOFLIGHT 123		•				•											66
SUCOFLIGHT 124		•				•											66
MINIBEND		•				•	•									•	73
MINIBEND L		•				•	•									•	76
MICROBEND		•				•	•									•	79
MICROBEND L		•				•	•									•	82
MINI 141		•				•											85
NANOBEND		•				•	•									•	88
MINI250H		•				•	•									•	91
SUCOTEST 145	•		•	•		•	•	•									xx
SUCOTEST 110	•		•	•		•	•	•									96
SUCOTEST 18		•				•											97
SUCOTEST 18A	•		•	•		•		•			•						97
TL-8A	•		•			•		•									102
TL-P	•		•			•		•	•								104
MULTIFLEX 86																	109
MULTIFLEX 86_HE	•			•													109
MULTIFLEX 141																	109
S 04272 B														•			113
S 04212 B														•			113
S 04262 B-01														•			113
MULTIFLEX 53-02	•			•							•						116
32071 (boa_Flex II)																	118
Eacon 2C										•							121
Eacon 4C										•							121
Eacon 6C										•							121

Selection guide – quick assembly selection matrix

Cable type	Outer diameter (mm)	Frequency range (GHz)	VOP (%)	nom. cable attenuation (dB/m @ 18 GHz)	nom. cable attenuation (dB/m @ 26.5 GHz)	nom. cable attenuation (dB/m @ 40 GHz)	nom. cable attenuation (dB/m @ 50 GHz)	nom. cable attenuation (dB/m @ 67 GHz)	nom. cable attenuation (dB/m @ 110 GHz)	CW power @ 1 GHz sea level / 25 °C	CW Power @ 18 GHz sea level / 25 °C	Min. temperature (°C)	Max. temperature (°C)	Min. bending radius (static) (mm)	Weight (g/m)
SUCOFORM 47 CU	1.2	40	71	5.44	6.79	8.62				36	9	-65	165	3.18	6
SUCOFORM 86	2.1	40	71	3.39	4.30	5.57				184	43	-65	165	6	15
SUCOFORM 141	3.58	33	71	2.23	2.89					484	114	-65	165	8	40
SUCOFORM 250-01	6.3	18	71	1.45						1047	247	-65	165	30	130
SUCOFORM 47 CU-LSFH	1.7	40	71	5.44	6.79	8.62				13	3	-40	85	4	7
SUCOFORM 86 PE	3.2	40	71	3.39	4.30	5.57				34	8	-40	85	6	19
SUCOFORM 86 FEP	2.5	40	71	3.39	4.30	5.57				319	75	-65	165	6	18
SUCOFORM 141 CU-PE	4.6	33	71	2.23	2.89					102	24	-40	85	8	47
SUCOFORM 141 CU-FEP	4.1	33	71	2.23	2.89					637	150	-65	165	8	47
SUCOFORM 250-01 FEP	6.8	18	71	1.45						1138	268	-65	165	30	138
SR 47 TP/M17	1.19	67	69.5	5.13	6.41	8.17	9.34	11.18		36	9	-40	100	3.18	7.1
SR 86 TP/M17	2.2	67	69.5	3.19	4.07	5.28	6.12	7.44		148	35	-40	125	3.18	24
SR 118 TP	2.95	40	80	1.76	2.17	2.72				680	160	-40	125	9.53	34
SR 141 TP/M17	3.58	33	69.5	2.09	2.73					512	121	-40	125	6.35	52
SR 250 TP/M17	6.35	18	69.5	1.50						1593	376	-40	90	19	158
SR 47 AL TP/M17	1.19	67	69.5	5.40	6.74	8.57	9.79	11.69		36	9	-40	100	1.27	3.1
SR 86 AL TP/M17	2.2	67	69.5	3.34	4.25	5.51	6.37	7.73		148	35	-40	125	1.78	11.9
SR 141 AL TP/M17	3.58	33	69.5	2.18	2.83					512	121	-40	125	3.18	30.5
SR 250 AL TP/M17	6.35	18	69.5	1.55						1593	376	-40	90	19	88.6
SUCOFORM_86_CT	2.15	40	80	3.18	4.08	5.37				188	44	-65	200	6	16
SUCOFORM_141_CT	3.58	30	83	1.93	2.48					430	101	-65	200	8	33
SR_86_CT	2.2	40	80	2.59	3.23	4.11	4.70	5.61		133	31	-55	200	3.18	9.3
SR_141_CT	3.58	33	83	1.8	2.28	2.95	3.40	4.12		364	86	-55	200	10	18
Minibend CT (32381)	2.50	70	81	4.54	5.64	7.13	8.12			201	47.3	-55	200	5.08	14.88
Mini141 CT (32322)	3.60	40	76	2.62	3.30	4.26						-55	200	5.08	14.88
MULTIFLEX_141_CT-02	4.2	40	84	1.97	2.49	3.2				370	87	-65	200	12	30.7
MULTIFLEX_210_CT	5	30	84	1.40	1.79					699	165	-65	200	27.5	45
MULTIFLEX_318_CT	7.5	18	84	1.00						1501	354	-65	200	42.5	90

Cable type	Recommended for dynamic applications	Qualified acc. to MIL standards	High crush resistant, armoured	Excellent phase stability vs. bending	Excellent phase stability vs. temperature	Cable assembly only	Stock assemblies available	RF test lead	PIM test lead	Field terminable	High flexlife	Handformable	Form-stable	Halogen-free	Flame retardant, halogen-free	Low profile connectors (bent to the end)	More information see page
SUCOFORM 47 CU												•					128
SUCOFORM 86												•					128
SUCOFORM 141												•					128
SUCOFORM 250-01												•					128
SUCOFORM 47 CU-LSFH												•					128
SUCOFORM 86 PE												•					128
SUCOFORM 86 FEP												•					128
SUCOFORM 141 CU-PE												•					128
SUCOFORM 141 CU-FEP												•					128
SUCOFORM 250-01 FEP												•					128
SR 47 TP/M17		•											•				135
SR 86 TP/M17		•											•				135
SR 118 TP													•				135
SR 141 TP/M17		•											•				135
SR 250 TP/M17		•											•				135
SR 47 AL TP/M17		•											•				135
SR 86 AL TP/M17		•											•				135
SR 141 AL TP/M17		•											•				135
SR 250 AL TP/M17		•											•				135
SUCOFORM_86_CT	•			•	•	•					•						142
SUCOFORM_141_CT	•			•	•	•					•						142
SR_86_CT					•								•				143
SR_141_CT					•								•				143
Minibend CT (32381)		•			•	•	•									•	145
Mini141 CT (32322)		•		•	•	•	•									•	145
MULTIFLEX_141_CT-02	•			•	•	•					•						146
MULTIFLEX_210_CT	•			•	•	•					•						146
MULTIFLEX_318_CT	•			•	•	•					•						146

Notes

- 1 DC continuity DC can be supplied on the centre conductor for remote powering
 - 2 Limited bandwidth no broadband operation only specific frequency bands can be transmitted
 - 3 High RF power application with more than 1 kW (CW) transmission power
 - 4 Very low RF power application with less than 50 W (CW) transmission power
- # No protector solution available featuring broadband operation and low PIM
- * Specific GDT has to be selected according to the transmitted RF power and DC supply voltage

HUBER+SUHNER AG
Radio Frequency
Degersheimerstrasse 14
9100 Herisau
Switzerland
Telefon +41 71 353 41 11
hubersuhner.com

HUBER+SUHNER is certified to ISO 9001, ISO 14001, ISO 45001, EN/AS 9100, IATF 16949 and ISO/TS 22163-IRIS.

Waiver

Fact and figures herein are for information only and do not represent any warranty of any kind.