

APPLICATION NOTE

SKY65120: WCDMA PA Bias Method For Lower Junction Temperature

Introduction

This application note describes how SKY65120 may be used with reduced bias control to obtain better thermal performance. It is especially useful for customers who may not have a suitable heat sink available directly below the PA module.

To achieve high gain (>23 dB), the SKY65120 consists of two stages of amplification. The base current of each amplification stage is controlled by an on-die active bias circuit. Each active bias circuit has its own reference voltage supply, V_{REF1} and V_{REF2} . The bias voltage (V_{C_BIAS}) is shared by the two active bias circuits.

This application note describes the active bias circuit used by SKY65120. The note explains the use of external supply voltages (V_{C_BIAS} and V_{REF}) and setting limits available to the customer. Test results of key parameters are also given over temperature.

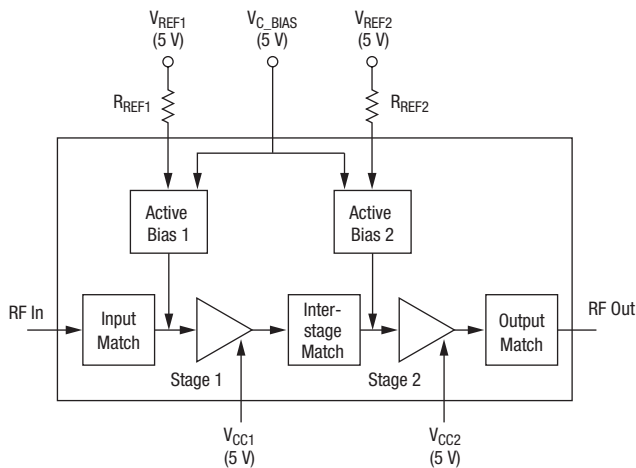

Figure 1. Functional Diagram of SKY65120 PA Module

Active Bias Circuit

Circuit Description

The active circuit is designed to maintain a constant supply current to the base of its respective transistor as supply voltage and temperature is changed. Each active bias circuit consists of three HBT transistors and three resistors, connected as shown in Figure 2 below.

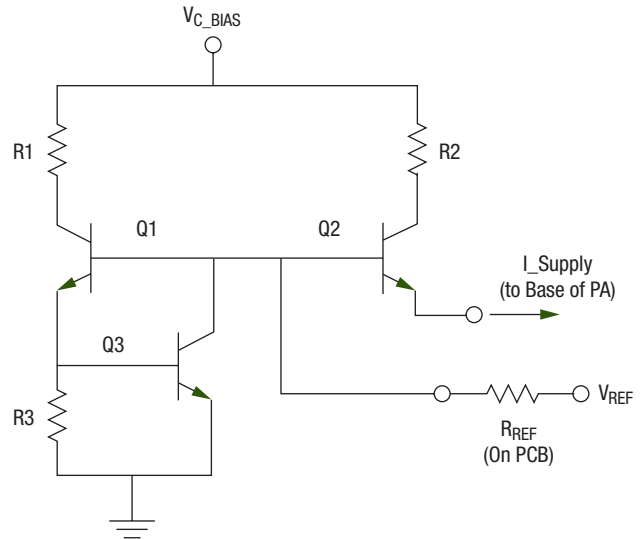

Figure 2. Schematic Diagram of Active Bias Circuit

APPLICATION NOTE • SKY65120: WCDMA PA BIAS METHOD FOR LOWER JUNCTION TEMPERATURE

Transistor Q3 is used as a thermal reference VT monitor, and is located on-die close to the amplifier transistor. This configuration allows stable PA module operation as the amplifier temperature changes.

The main supply voltage to the bias circuits, V_{C_BIAS} , should be set to 5 V, and is internally connected to both bias circuits.

Reference voltages, V_{REF1} and V_{REF2} are made available to the user to allow PA ON/OFF switching; and a certain amount of gain and current control. When the V_{REF} voltages are set to zero, Q1

and Q2 switches off, and effectively remove the supply current to the associated amplifier stage.

Reference resistors, R_{REF1} and R_{REF2} (located on the customer PCB) can be used to trim the base reference current. Alternately, the R_{REF} can be fixed and V_{REF} voltages can be modified. For $V_{REF1} = V_{REF2} = 5$ V, the recommended values for these reference resistors are:

$R_{REF1} = 390$ Ohms,

$R_{REF2} = 120$ Ohms.

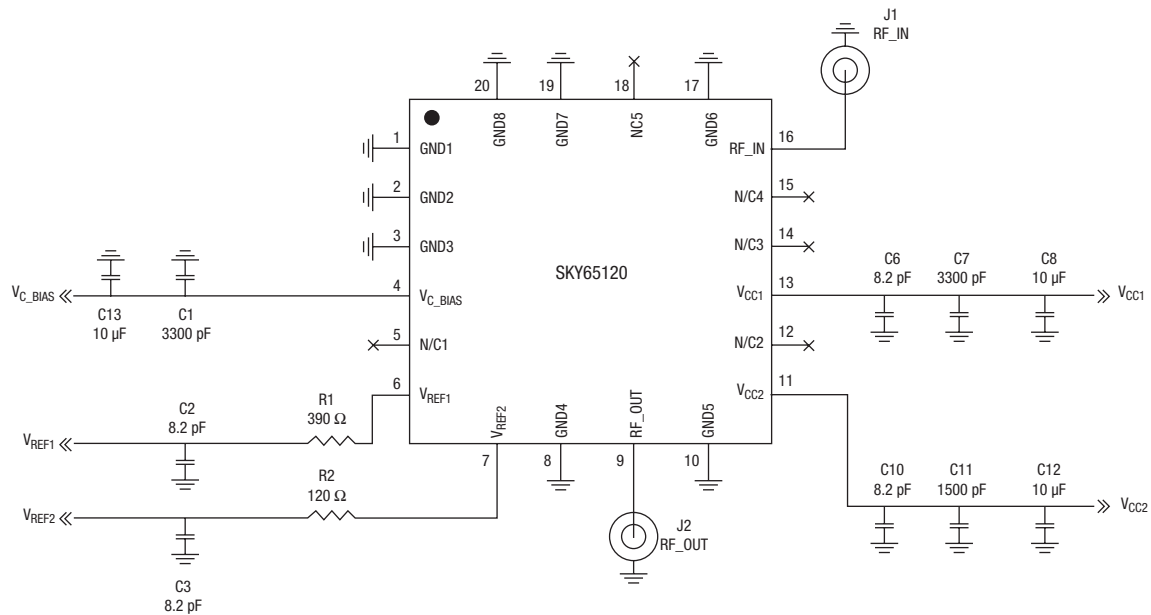

Figure 3. SKY65120 Evaluation Board Schematic

Effect Of Reducing V_{REF}

The second stage transistor consumes the most current, whereas the first stage transistor has the most impact of overall gain. Therefore, to reduce junction temperature without severely impacting module gain, it is best to modify V_{REF2} . Table 1 below presents the results of changing V_{REF2} from 4.0 V to 5.0 V.

The results show maximum output power (for ACLR = -45 dBc) has only slight degradation (i.e. 0.2 dB), when V_{REF} is reduced

from 5.0 V to 4.0 V. However, the operating current is reduced by 77 mA, and case temperature is reduced from 73 °C to 61 °C.

Note: All measurements taken at 25 °C, with the heat-sink removed from the evaluation board. All other supply voltages fixed at 5 V.

Table 1: Maximum P_{OUT}, Gain, I_{CC} and Case Temperature vs. V_{REF2}

V _{REF2} (V)	P _{IN} (dBm)	P _{OUT} (dBm)	Gain (dB)	I _{CC} (mA)	Case Temp (°C)
5.0	1.95	24.8	22.85	554	72.8
4.8	1.75	24.8	23.05	527	71.6
4.5	1.55	24.8	23.25	515	69.8
4.3	1.45	24.75	23.3	504	64.1
4.0	1.25	24.6	23.35	477	61.0

Measured Junction Temperature

IR-scans were conducted on devices with case temperature set to 85 °C, with various combinations of V_{REF1} and V_{REF2}. At each setting, output power was adjusted to 21 dBm. Table 2 shows the measured maximum junction temperature at each V_{REF1} and V_{REF2} combination.

The temperature data shows the lowest junction temperature and current consumption are achieved when V_{REF1} = V_{REF2} = 4 V.

IR-scan plot for V_{REF1} = V_{REF2} = 4 V is shown in Figure 4 below.

Table 2: Maximum Junction Temperature vs. V_{REF} (Case Temperature = 85 °C)

V _{CC1} ; V _{CC2} (V)	V _{G_BIAS} (V)	V _{REF1} (V)	V _{REF2} (V)	I _{CC1} (mA)	I _{CC2} (mA)	I _{CC-Total} (mA)	P _{OUT} (dBm)	Measured Peak T _{jmax} (°C)
5	5	5.0	4.5	74	374	448	21	138
5	5	5.0	4.0	76	327	403	21	130
5	5	4.5	4.5	70	375	445	21	136
5	5	4.5	4.0	69	328	397	21	131
5	5	4.0	4.5	63	377	440	21	137
5	5	4.0	4.0	63	329	392	21	129

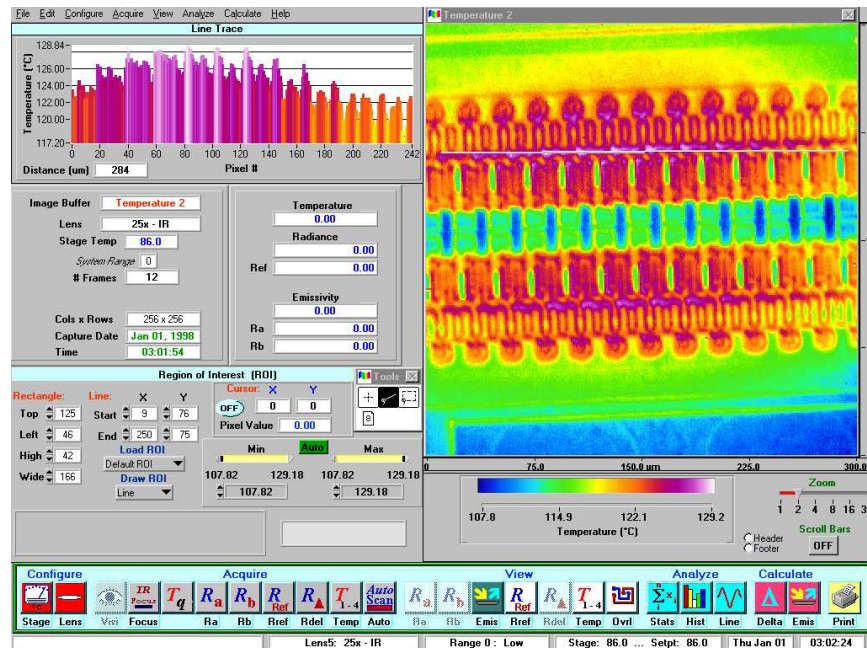

Figure 4. IR-scan Plot Showing Thermal Profile Across Amplifier with V_{REF1} = V_{REF2} = 4 V, Case Temperature = 85 °C, and P_{OUT} = 21 dBm

Summary and Recommendation

RF and IR-scans tests were conducted on the SKY65120 amplifier module to determine the best method for biasing the module to reduce case and junction temperature in conditions where a heat-sink may not be available.

The results presented shows V_{REF2} can be set to 4.0 V with no significant degradation of gain and ACLR performance.

The best temperature profile can be obtained with $V_{REF1} = V_{REF2} = 4.0$ V. With no heat-sink and case temperature to 85 °C, the maximum junction temperature was measured at 129 °C.

Note: *IR-scans were done with an earlier set of the evaluation board component values than those referenced in the data sheet. While the absolute results may be different, the principles and methods described in this application note still apply. Please refer to the SKY65120 data sheet for the latest evaluation board component values.*

Copyright © 2009, Skyworks Solutions, Inc. All Rights Reserved.

Information in this document is provided in connection with Skyworks Solutions, Inc. ("Skyworks") products or services. These materials, including the information contained herein, are provided by Skyworks as a service to its customers and may be used for informational purposes only by the customer. Skyworks assumes no responsibility for errors or omissions in these materials or the information contained herein. Skyworks may change its documentation, products, services, specifications or product descriptions at any time, without notice. Skyworks makes no commitment to update the materials or information and shall have no responsibility whatsoever for conflicts, incompatibilities, or other difficulties arising from any future changes.

No license, whether express, implied, by estoppel or otherwise, is granted to any intellectual property rights by this document. Skyworks assumes no liability for any materials, products or information provided hereunder, including the sale, distribution, reproduction or use of Skyworks products, information or materials, except as may be provided in Skyworks Terms and Conditions of Sale.

THE MATERIALS, PRODUCTS AND INFORMATION ARE PROVIDED "AS IS" WITHOUT WARRANTY OF ANY KIND, WHETHER EXPRESS, IMPLIED, STATUTORY, OR OTHERWISE, INCLUDING FITNESS FOR A PARTICULAR PURPOSE OR USE, MERCHANTABILITY, PERFORMANCE, QUALITY OR NON-INFRINGEMENT OF ANY INTELLECTUAL PROPERTY RIGHT; ALL SUCH WARRANTIES ARE HEREBY EXPRESSLY DISCLAIMED. SKYWORKS DOES NOT WARRANT THE ACCURACY OR COMPLETENESS OF THE INFORMATION, TEXT, GRAPHICS OR OTHER ITEMS CONTAINED WITHIN THESE MATERIALS. SKYWORKS SHALL NOT BE LIABLE FOR ANY DAMAGES, INCLUDING BUT NOT LIMITED TO ANY SPECIAL, INDIRECT, INCIDENTAL, STATUTORY, OR CONSEQUENTIAL DAMAGES, INCLUDING WITHOUT LIMITATION, LOST REVENUES OR LOST PROFITS THAT MAY RESULT FROM THE USE OF THE MATERIALS OR INFORMATION, WHETHER OR NOT THE RECIPIENT OF MATERIALS HAS BEEN ADVISED OF THE POSSIBILITY OF SUCH DAMAGE.

Skyworks products are not intended for use in medical, lifesaving or life-sustaining applications, or other equipment in which the failure of the Skyworks products could lead to personal injury, death, physical or environmental damage. Skyworks customers using or selling Skyworks products for use in such applications do so at their own risk and agree to fully indemnify Skyworks for any damages resulting from such improper use or sale.

Customers are responsible for their products and applications using Skyworks products, which may deviate from published specifications as a result of design defects, errors, or operation of products outside of published parameters or design specifications. Customers should include design and operating safeguards to minimize these and other risks. Skyworks assumes no liability for applications assistance, customer product design, or damage to any equipment resulting from the use of Skyworks products outside of stated published specifications or parameters.

Skyworks, the Skyworks symbol, and "Breakthrough Simplicity" are trademarks or registered trademarks of Skyworks Solutions, Inc., in the United States and other countries. Third-party brands and names are for identification purposes only, and are the property of their respective owners. Additional information, including relevant terms and conditions, posted at www.skyworksinc.com, are incorporated by reference.